

# AdvancedMC™ Reference Design

## MPC8548E general-purpose processing card

### Featuring

- MPC8548E
  - Powerful and flexible PowerQUICC® III processor
  - e500 core, built on Power Architecture™ technology, up to 1.33 GHz
  - 3065 MIPS at 1.33 GHz (Dhrystone 2.1)
  - Integrated security engine—DES, 3DES, MD-5, Kasumi
  - Eases board control, security and control I/O processing
  - Eliminates the need for separate security processor
  - Helps reduce system footprint and costs
- Application area
  - Control plane, security and board control processing within:
    - .. Base transceiver station (BTS)
    - .. Radio network controller (RNC)
    - .. Media gateway (MGW)
    - .. Enterprise network
    - .. Test and measurement
    - .. Server blades
- Reference design collateral
  - Comprehensive pack of design collateral
  - Assists customer designs and reduces time to market
- Supports industry-standard rack options
  - AdvancedTCA® (ATCA) or MicroTCA™



### Speeding up Development, Intercepting Markets

Rapid time to market is one of the most critical success factors for any business. With this ever increasing pressure, the need to quickly prototype and develop designs and systems can be a key engineering bottleneck. As part of Freescale's ATCA/AdvancedMC™ (AMC) Rapid System Development Program, the reference designs are free design examples with supporting collateral to help accelerate the design and systems building process.

Each of the reference designs are supported with collateral comprised of detailed designed specifications, schematics, Gerbers, firmware code/files and software such as board support packages (BSPs) and drivers.

The MPC8548E-based AMC design example featured here is aimed at high-performance control plane and board control applications. The high-performance e500 core can provide a range of control plane, security and boards control processing within the BTS, MGW, RNC, enterprise networks and server blades. Additionally, the on-chip security engine can be used for a range of security algorithms such as DES, 3DES, MD-5 and Kasumi.

### Reference Design Collateral

- Detailed Design Specifications (DDS): Details the specifications of the design example. Helps customers understand the architecture and components used in the design.
- Schematics: Comprehensive design level schematics. Aids and accelerates the design process by giving customers full design level connectivity and component values.
- Gerber Files: Design example Gerber data to assist manufacturing—drilling diagrams, routing plots, tracking and hole dimensions, etc.
- Firmware: Design example code for on-board CPLDs, FPGAs and ROMs.
- Software: BSPs, drivers and demo applications to assist in design, board and application bring-up.
- Device Data Sheet Links: Quick links to all online Freescale device data sheets and resources to speed up device knowledge.

Note: All design examples are provided "AS IS". The reference design collateral may be subject to registration, license, or other agreement.

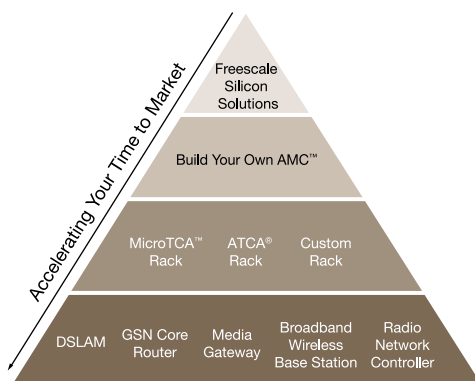

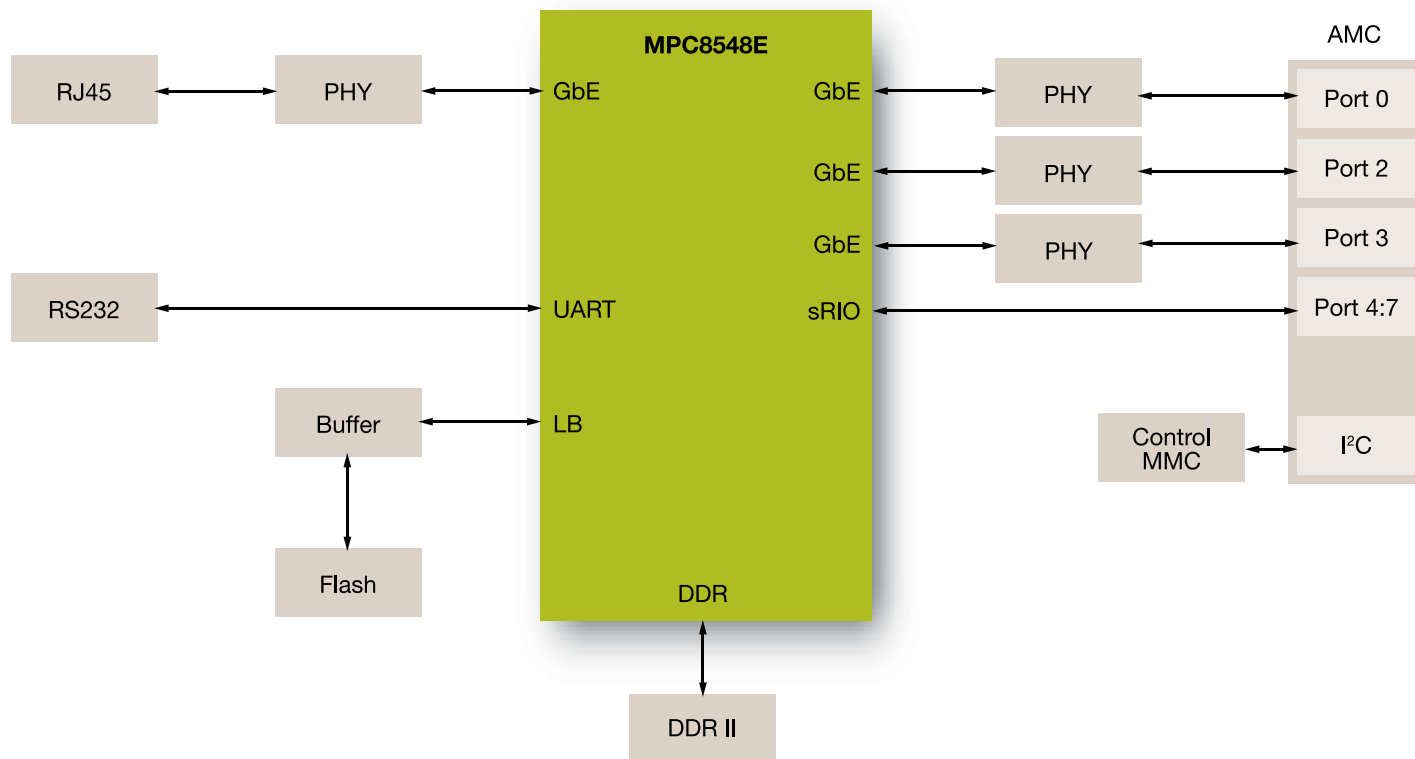

**Board Level Device Features**

- MPC8548E
  - e500 v2 core, built on Power Architecture technology, at up to 1.33 GHz
  - 3065 MIPS at 1.33 GHz (Dhrystone 2.1)
  - 512 KB on-chip L2 cache
  - 4 x Gigabit Ethernet (GbE) interfaces
  - DDR memory controller: 333 MHz, 64-bit
  - Security engine—DES, 3DES, MD-5, Kasumi
  - x8 PCI Express® support or:
  - Single x4 PCI Express + single x4 Serial RapidIO® support
  - Local bus flash interface

**Board Memory**

- SODIMM—Up to 256 MB DDR II
- 16 MB flash memory
- Serial RapidIO (Port 4:7)

**Board I/O**

- AMC connector
  - 3 x Gigabit Ethernet interfaces (Port 0,2,3)
- Front panel
  - Gigabit Ethernet interface (RJ45)
  - RS232
- Headers and debug
  - JTAG/COP

**Application Area**

Control plane, security and board control processing within:

- BTS
- MGW
- Enterprise network
- Test and measurement
- Server blades

**Learn More:** For more information about Freescale's ATCA/ AMC Rapid System Development Program, please visit [www.freescale.com/atca](http://www.freescale.com/atca).



Freescale® and the Freescale logo are trademarks of Freescale Semiconductor, Inc. All other product or service names are the property of their respective owners. The Power Architecture and Power.org word marks and the Power and Power.org logos and related marks are trademarks and service marks licensed by Power.org.  
© Freescale Semiconductor, Inc. 2007

Document Number: MPC8548AMCFS  
REV 2

