

BLE Antenna Design Guide

Rev 2.0 — May 2018

Application note

Document information

Info	Content
Keywords	Micro-Strip Antenna, Metal plate antenna, Chip antenna, test procedure
Abstract	This document is served as a basic antenna selection guide for the customer.



Revision history

Rev	Date	Description
0.1	20130607	Initial release
0.2	20130709	Grammatical corrections made some text added
1.0	20150324	Reviewed and migrated to NXP template
2.0	20180509	Removed the security watermark

Please be aware that important notices concerning this document and the product(s) described herein, have been included in the section 'Legal information'.

Contents

Contents	3
1. Overview	4
2. Typical BLE antennas comparing	4
3. Micro-Strip Antenna	5
3.1 Overview	5
3.1 Design steps.....	6
3.2 Some examples of micro-strip antenna	6
3.2.1 Micro-strip “L” antenna	6
3.2.2 Micro-strip bow-shaped antenna	9
3.2.3 Micro-strip circularly polarized antenna	12
3.2.4 Micro-strip inverted-F antenna.....	15
4. Metal plate antenna	21
4.1 Overview	21
4.2 Some examples of this antenna	22
4.2.1 Metal plate antenna applied in NEURON project	22
4.2.2 Metal plate antenna used in iCoin project.....	27
5. Chip antenna	31
5.1 List of chip antenna suppliers	31
5.2 Some of typical products by these suppliers	32
5.3 Placement of chip antenna on PCB.....	35
6. Test Procedure for antenna	36
6.1 Network analyzer calibration	37
6.2 Measurement of antenna Return Loss, Impedance and Bandwidth	37
6.3 Description of the measurement result.....	38
6.4 How to design matching net for antenna	39
7. Legal information	41
7.1 Definitions.....	41
7.2 Disclaimers.....	41
7.3 Trademarks	41
8. List of figures	42
9. List of tables	43

Contact information

For more information, please visit: <http://www.nxp.com>

1. Overview

The following document serves as a basic antenna selection guide for the customer. Various antennas are showcased and insight on their dimension, design process, radio frequency performance, PCB layout, etc. is provided. This is to allow the customer to select an appropriate antenna for their application. Detailed design questions or concerns should be communicated to the FAE at NXP.

A small description with regards to Antenna test procedure is also presented. Some of the Antenna’s discussed in this note may require more detailed simulation depending on the actual application. From the types of Antenna’s discussed, chip antenna’s have the smallest footprint but are low on efficiency, similarly microstrip antenna’s are cheap but are tedious in design and the metal antenna’s have high efficiency. In order to guide the customer a few Antenna suppliers are mentioned, so that customers can also have option of directly buying from them.

For the Antenna’s described in this note, 50 Ohm input impedance has been considered along with Omni-directional radiation pattern with a center frequency of 2.45GHz.

2. Typical BLE antennas comparing

The Following table shows the three antenna types that will be briefly discussed in this app note. A very basic comparison of key parameters has been shown as well. This chart helps the customer to qualify a specific antenna type for their application.

Table 1 Typical BLE antennas comparing

	Micro-strip antenna	Metal plate antenna	Chip antenna
Efficiency	Moderate	High	Low

Cost	Low	High	Moderate
Bandwidth	High	Low	Moderate
Average Gain	Moderate	High	Low
Dimension	Moderate	High	Low
Typical Applications	Sports, fitness, healthcare, medical, remote control	Sports, fitness, healthcare, medical, remote control	Sports, fitness, healthcare, medical, remote control
Polarization	Linear	linear	Linear
Power Handling	Low	high	Medium
Typical Impedance	50ohm	50ohm	50ohm

3. Micro-Strip Antenna

3.1 Overview

The Micro-Strip antenna is one of the most popular antennas, because of its low cost and ease of production. With the help of advanced simulation tools such as HFSS, Microwave Office and ADS, it has become easier to design and develop such antennas. The micro-strip antenna can also be seen as a simple fracture antenna due to its flexible appearance. The micro-strip antenna RF performance is highly depended on the size of the reference ground. Therefore, changing the default reference ground size, the antenna RF characteristic including the resonance frequency, port input impedance, etc, will change as well.

The micro-strip antenna can be designed as a circular polarized antenna. One example will be illustrated in this document, such a design may occupy more PCB area compared to other typical micro-strip antennas.

Micro-strip antennas can be designed into antenna arrays to get high antenna gain, which is not used widely in the consumer electronics products due to the increased PCB size.

3.1 Design steps

Following are some basic steps required to bring up the design.

- ◆ Select the antenna type, for example, monopole, dipole or IFA antenna;
- ◆ Roughly calculate the antenna dimension using the experience formula;
- ◆ Set up the simulation module using simulation tools, such as, HFSS, ADS;
- ◆ Simulate and adjust the antenna dimension till the simulation result meets the requirement;

The third step is the most critical. If the antenna model is not correct or has significant error, caused by incorrect parameters or module structure, the simulation result may be incorrect. S11, bandwidth, input impedance, gain, cross polarization and axial ratio are the determining parameters for the antenna performance.

3.2 Some examples of micro-strip antenna

3.2.1 Micro-strip “L” antenna

As a micro-strip antenna, the L shaped antenna is the simplest solution. Its resonance frequency is related with the antenna line width “w”, the antenna length “L”, the dimension and the dielectric constant of the substrate. Shown below is an example of such a design. The dielectric constant for the FR4 substrate is 4.4, the thickness is 0.5mm. Following figure shows the dimension and layout of the antenna.

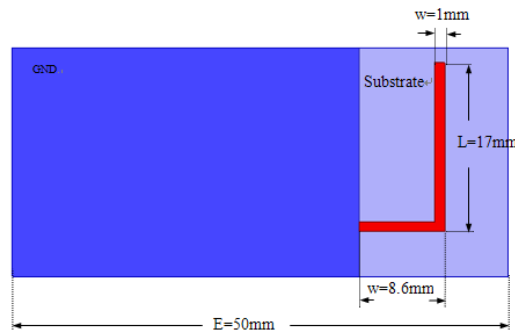

Figure 1 “L” antenna dimension

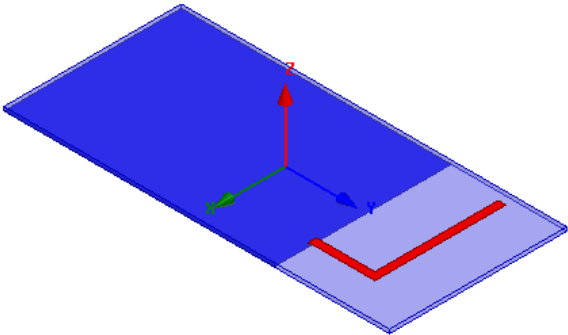

Figure 2 "L" antenna 3D structure

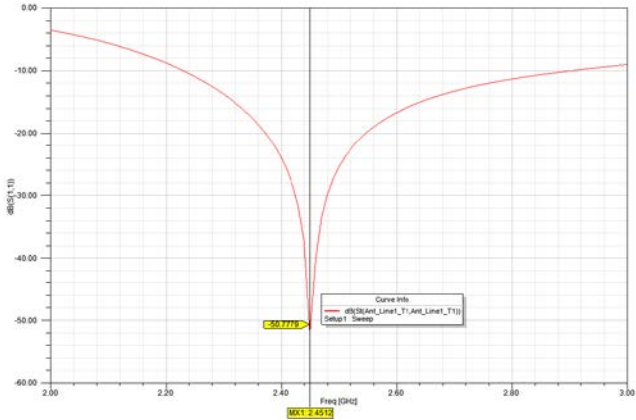

Figure 3 "L" antenna S11 performance

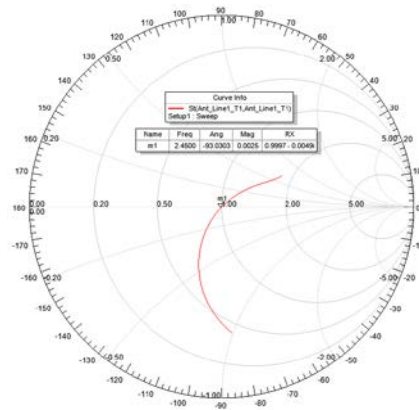

Figure 4 "L" antenna Smith chart

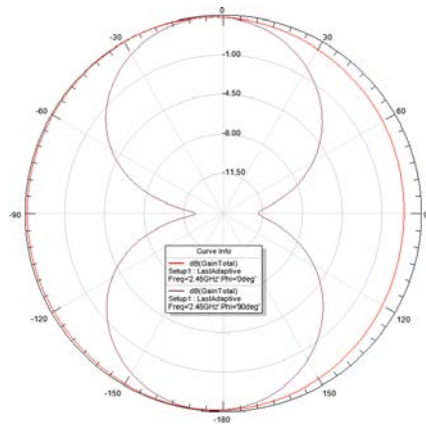

Figure 5 "L" antenna EH plane gain characteristic

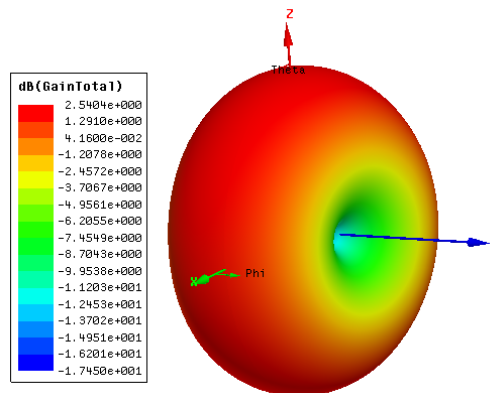

Figure 6 "L" antenna 3D radiation pattern

Table 2 Effect on performance when critical dimensions are altered

Antenna Dimension	Change	Parameter	Effect
w	Increase	Resonance frequency	Increase
		Bandwidth	Becomes wide
	Decrease	Resonance frequency	Decrease
		Bandwidth	Becomes narrow
L	Increase	Resonance frequency	Decrease
		Bandwidth	Becomes narrow
	Decrease	Resonance frequency	Increase
		Bandwidth	Becomes wide
E	Increase	Resonance frequency	Decrease
		Bandwidth	Becomes wide
	Decrease	Resonance frequency	Increase
		Bandwidth	Becomes narrow

3.2.2 Micro-strip bow-shaped antenna

This is another widely used monopole antenna. Its resonance frequency is in correspondence with the antenna line width “w”, the line gap “D”, the line length “L”, and dielectric constant of the substrate. FR4 with a dielectric constant of about 4.4 is used in the following illustration. In order to get better radiation efficiency it is advised that the area without the reference ground copper be enlarged.

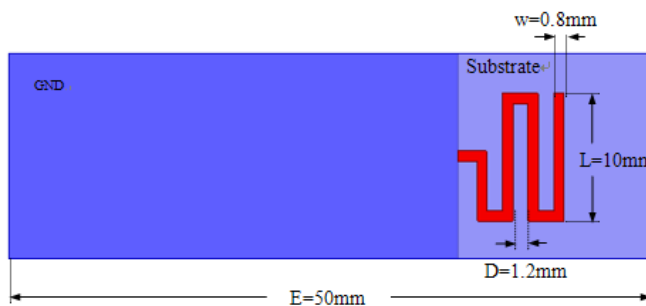

Figure 7 Bow shaped antenna dimension

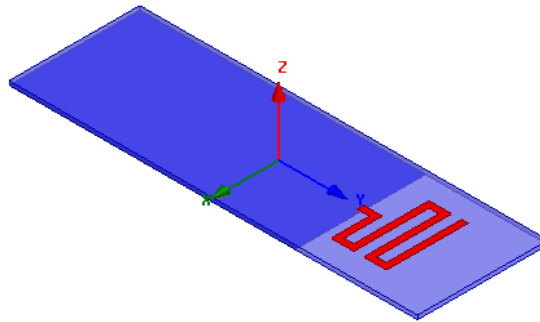

Figure 8 Bow shaped antenna 3D structure

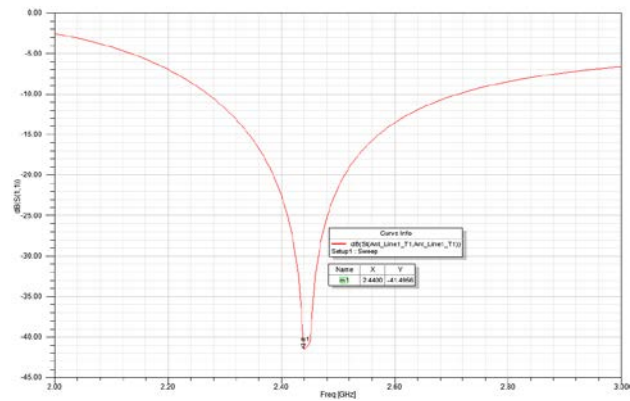

Figure 9 Bow shaped antenna S11 performance

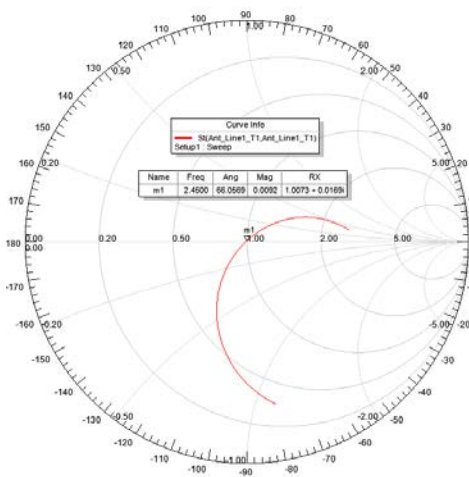

Figure 10 Bow shaped antenna Smith chart

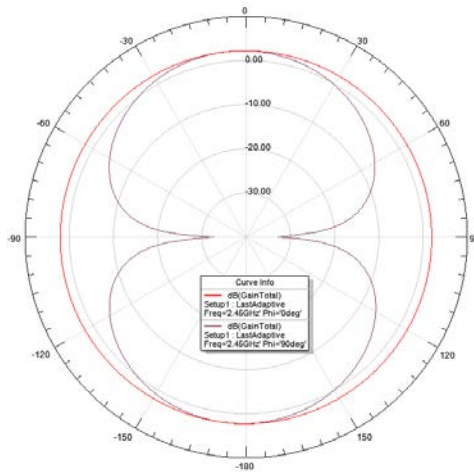

Figure 11 Bow shaped antenna EH plane gain characteristic

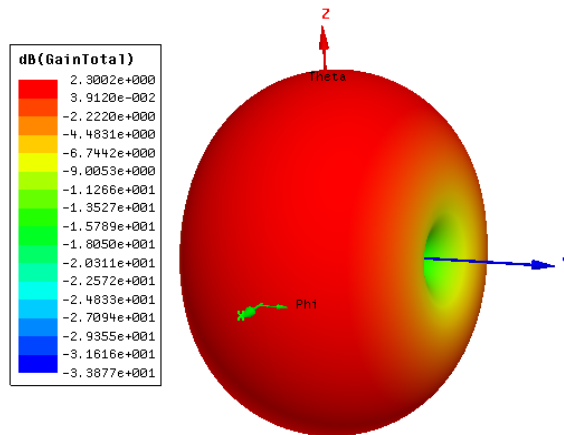

Figure 12 Bow shaped antenna 3D radiation pattern

Table 3 Effect on performance when critical dimensions are altered

Antenna Dimension	Change	Parameter	Effect
w	Increase	Resonance frequency	Increase
		Bandwidth	Becomes wide
	Decrease	Resonance frequency	Decrease
		Bandwidth	Becomes narrow
L	Increase	Resonance frequency	Decrease
		Bandwidth	Becomes narrow

D	Decrease	Resonance frequency	Increase
		Bandwidth	Becomes wide
	Increase	Resonance frequency	Decrease
		Bandwidth	Becomes narrow
E	Decrease	Resonance frequency	Increase
		Bandwidth	Becomes wide
	Increase	Resonance frequency	Decrease
		Bandwidth	Becomes wide
Decrease	Resonance frequency	Increase	
	Bandwidth	Becomes narrow	

3.2.3 Micro-strip circularly polarized antenna

One of the popular micro-strip antennas is the circularly polarized configuration. The PCB area required to implement such an antenna is comparatively larger than linear polarized antenna, but the antenna receive performance is better. The theory of realizing circular polarization requires two linear polarization electric field vectors simultaneously; both of the vectors must be orthotropic and have 90° phase difference between them. One important parameter for this antenna is the axial ratio, which is required to be lower than 3dB. There are many ways to realize circular polarization micro-strip antenna. The following is one example.

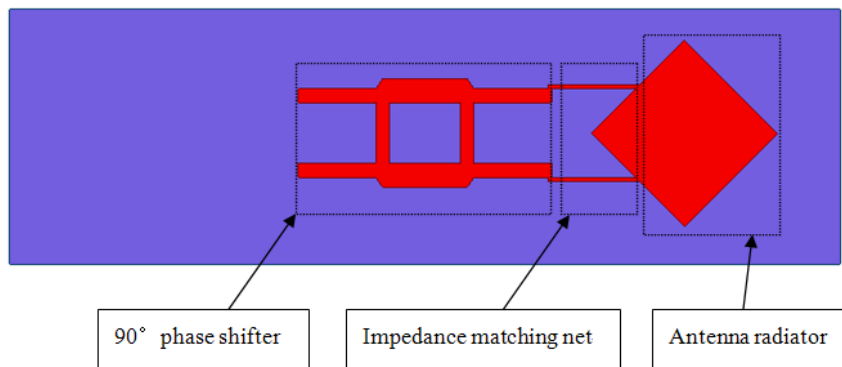

Figure 13 circularly polarized antenna structure

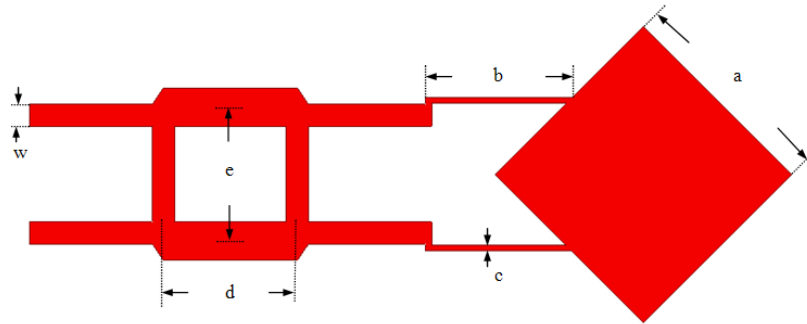

Figure 14 circularly polarized antenna dimension

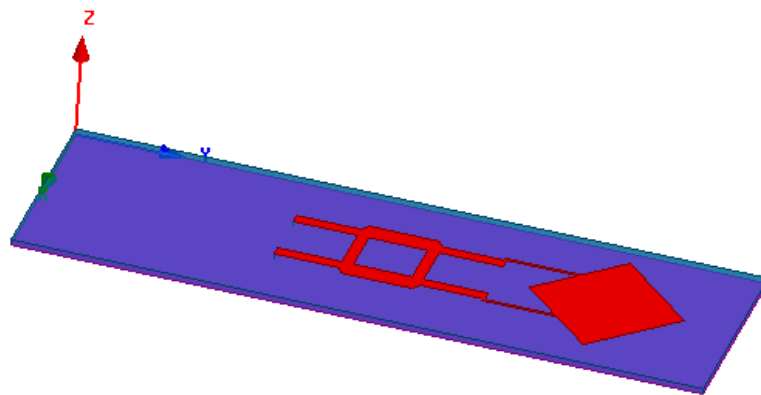

Figure 15 circularly polarized antenna 3D structure

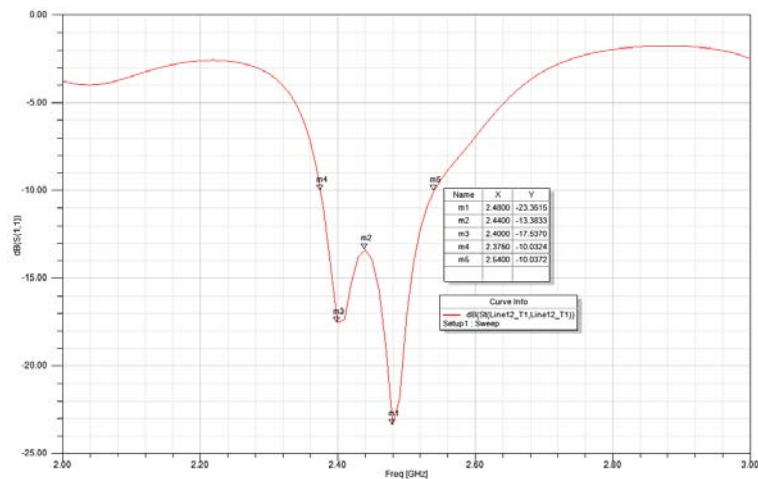

Figure 16 circularly polarized antenna S11 performance

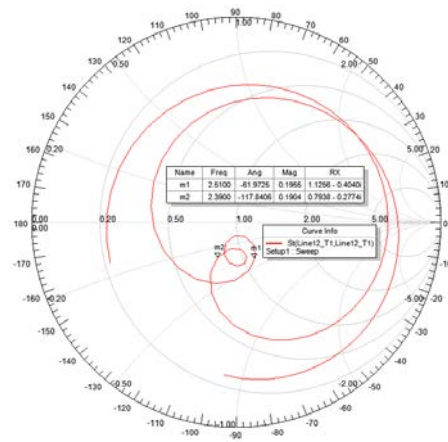

Figure 17 circularly polarized antenna Smith chart

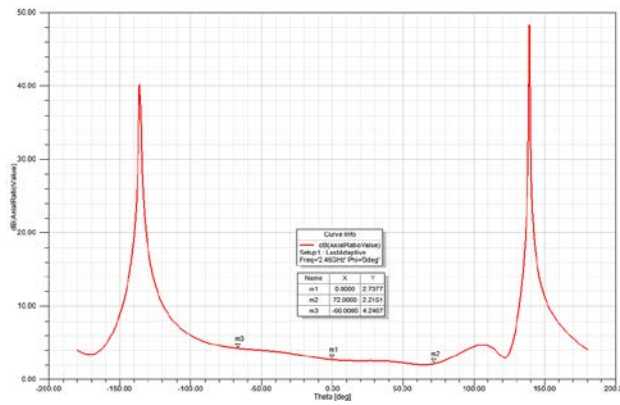

Figure 18 circularly polarized antenna axial ratio characteristic (1)

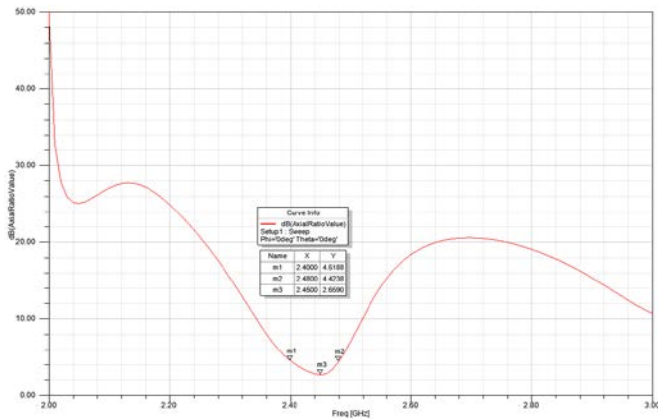

Figure 19 circularly polarized antenna axial ratio characteristic (2)

3.2.4 Micro-strip inverted-F antenna

The inverted-F antenna is easy to design, and quite popularly used in various BLE applications, such as USB dongles, Proximity, heart rate monitor (HRM), human interface device (HID) etc. The IFA antenna is used widely due to its excellent performance and small size, therefore it has been described in detail.

Following figure illustrates the structure of a simple inverted-F antenna. The expected resonance frequency of this antenna is 2.44G.

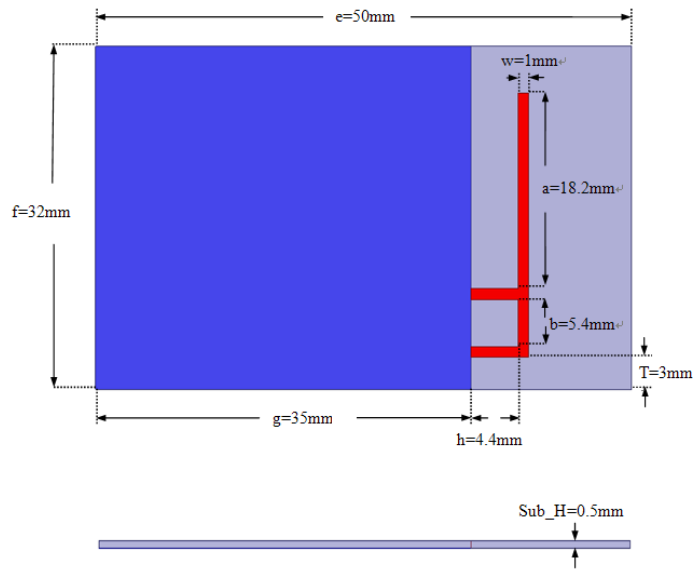

Figure 20 IFA antenna dimension

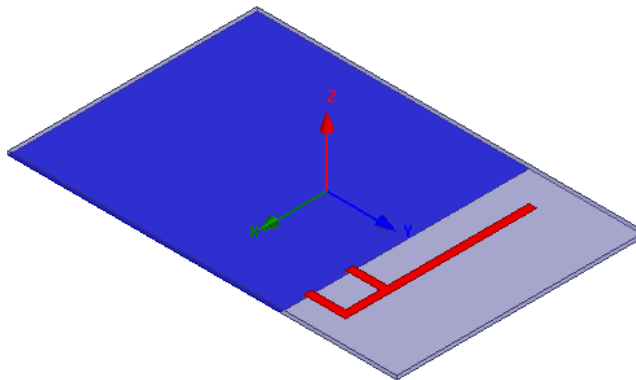

Figure 21 IFA antenna 3D structure

While laying out the IFA PCB attention to some key features is required:

1. The feed arm should be fed with a 50ohm CPWG transmission line. The length of the transmission line should be as short as possible. The transmission line can be covered by mask.
2. The short arm should be connected to the reference ground plane with at least 2 vias.
3. The ground plane under the antenna should be removed.
4. The solder-mask plane on and under the antenna should be added.
5. The ground plane on the different layers should be connected together by vias along the ground plane edge.
6. The dimension of the ground plane is as important as the antenna dimension itself.
7. The layout of the matching net should not alter the impedance of transmission line.
8. One “T” or pie matching net is generally enough for all kinds of antennas. The matching net should be as simple as possible.

If there is a change in the dimensions of the substrate, the antenna dimension should also be changed. Any change to the dimension marked in Figure above may change the antenna RF performance including resonance frequency and input impedance. The changes should be based on the simulation result. It is recommended to use simulation tool to design and debug the antenna. The antenna position dimension is also very important for the antenna design. As shown in Figure above, the position dimension is “T”.

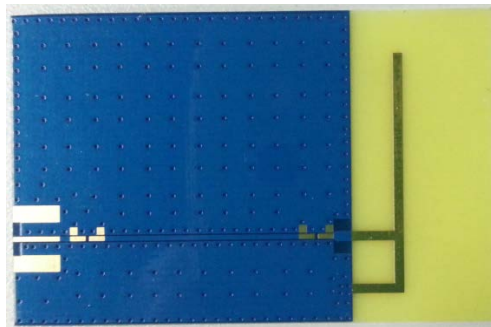

Figure 22 IFA antenna PCB layout

We usually use CPWG (Coplanar waveguide) as the feed line for the antenna. The characteristic impedance of the CPWG should equal the input impedance of the antenna; in order to improve the return loss at the antenna input port 50ohm input impedance is used as a standard. It is not recommended to use the microstrip line as the feed line because it will change the antenna's effective electric

length. Around the ground plane small vias connected to ground should be placed, such that their diameter is between 8 to 10 mils.

The matching net should not be removed even if the impedance match between the feed line and antenna is optimum. In order to avoid errors due to unpredictable issues, such as manufacturing error, dielectric constant error, etc., the matching net should always be present between the feed line and the antenna. Generally, one T or π matching net is enough for most of antenna applications. The component pad size of the matching net should be suitable for the feed line dimension. The matching net design in Figure 2 can be seen as a reference design.

The inverted-F antenna metal should be open to air, with nothing covering it. If not, it will restrain the surface wave generation. In addition, the substrate on the inverted-F antenna area should not have any mask.

The inverted-F antenna performance can be affected by many factors, like the PCB board size, the substrate dielectric constant, the antenna size, and the antenna position on PCB board. The following section shows how these parameters affect the antenna performance.

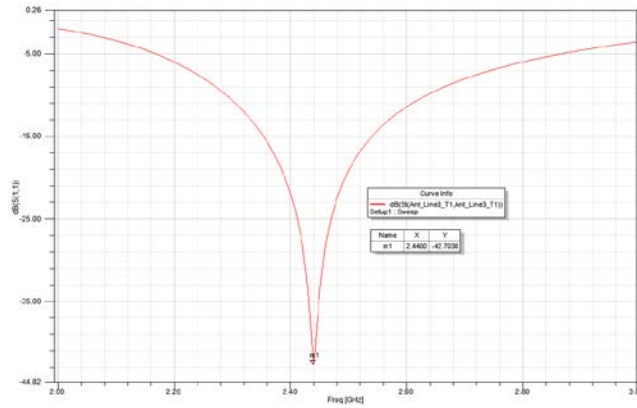

Figure 23 IFA antenna S11 performance

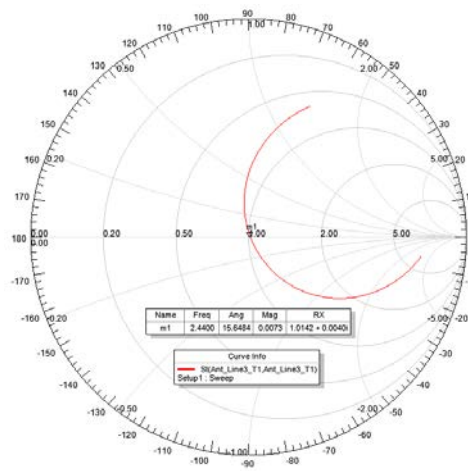

Figure 24 IFA antenna Smith chart

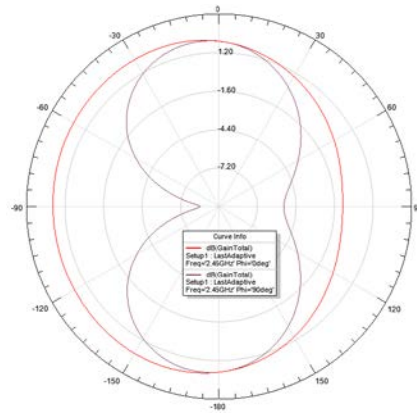

Figure 25 IFA antenna EH plane gain characteristic

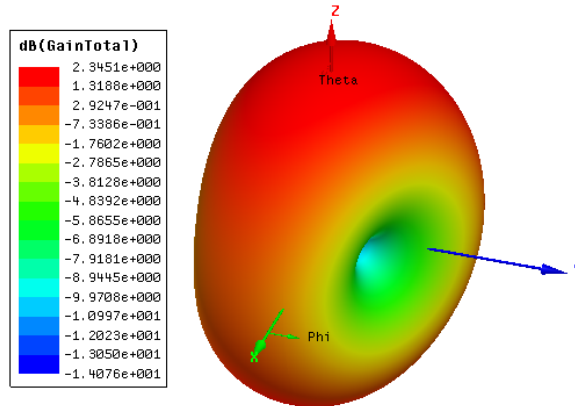

Figure 26 IFA antenna 3D radiation pattern

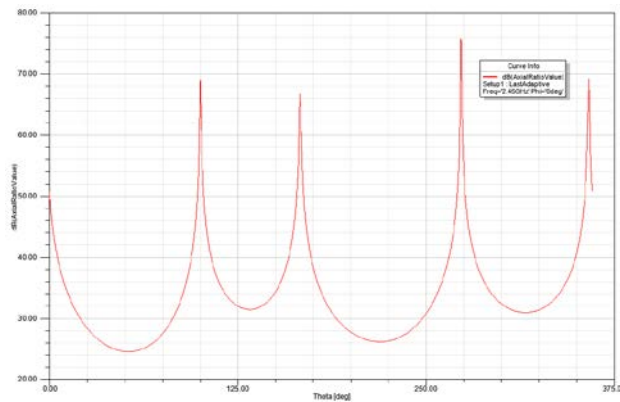

Figure 27 IFA antenna axial ratio performance

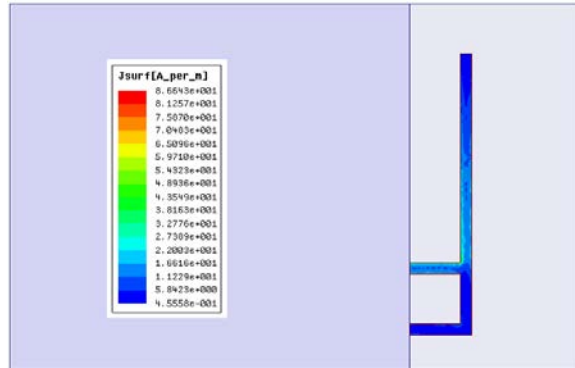

Figure 28 IFA antenna current amplitude distribution

Table 4 Effect on performance when critical parameters are altered

Antenna dimension	change	parameter	effect
e	Increase	Resonance frequency	Decrease
		Bandwidth	Becomes wide
	Decrease	Resonance frequency	Increase
		Bandwidth	Becomes narrow
f	Increase	Resonance frequency	Decrease
		Bandwidth	Becomes narrow
	Decrease	Resonance frequency	Increase
		Bandwidth	Becomes wide
g	Increase	Resonance frequency	Increase
		Bandwidth	Becomes wide
	Decrease	Resonance frequency	Decrease
		Bandwidth	Becomes narrow
b	Increase	Resonance frequency	Decrease
		Bandwidth	Becomes wide
	Decrease	Resonance frequency	Increase
		Bandwidth	Becomes narrow
Sub_H	Increase	Resonance frequency	Decrease
		Bandwidth	Becomes narrow

	Decrease	Resonance frequency	Increase
		Bandwidth	Becomes wide
T	Increase	Resonance frequency	Increase
		Bandwidth	Becomes wide
	Decrease	Resonance frequency	Decrease
		Bandwidth	Becomes narrow
h	Increase	Resonance frequency	Decrease
		Bandwidth	Becomes narrow
	Decrease	Resonance frequency	Increase
		Bandwidth	Becomes wide
a	Increase	Resonance frequency	Decrease
		Bandwidth	Becomes narrow
	Decrease	Resonance frequency	Increase
		Bandwidth	Becomes wide
w	Increase	Resonance frequency	Decrease
		Bandwidth	Becomes wide
	Decrease	Resonance frequency	Increase
		Bandwidth	Becomes narrow
ϵ (dielectric constant of the substrate)	Increase	Resonance frequency	Decrease
		Bandwidth	Becomes narrow
	Decrease	Resonance frequency	Increase
		Bandwidth	Becomes wide

4. Metal plate antenna

4.1 Overview

The metal plate antenna is a high efficiency, high power handling antenna solution used widely for various 2.4GHz application solutions such as fitness, healthcare, medical, remote control, etc. It can be designed to monopole, dipole and IFA antennas, but is usually designed as IFA to reduce the antenna size. In addition, its performance including bandwidth characteristic is much depended on the dimension of the PCB board. Larger

PCB board means a wider antenna bandwidth. Following is an example of the metal plate antenna.

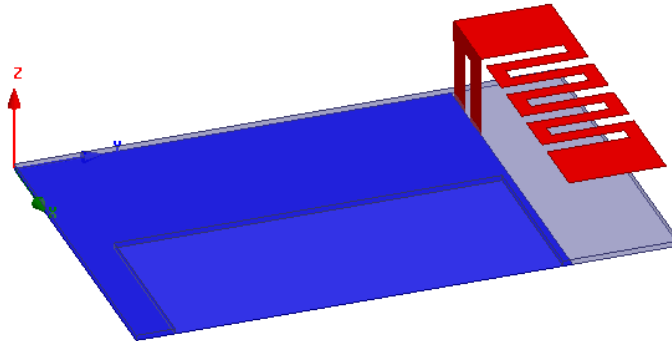

Figure 29 Metal plate antenna 3D structure

In this figure, the red part is the metal plate antenna, and it is an IFA antenna. The gray area is the clearance space of the PCB board. The antenna is usually made of stainless steel and its default thickness is about 0.15 millimeters. The design steps are similar to that of the micro-strip antenna.

4.2 Some examples of this antenna

In section provides some antenna examples, most of the designs have been verified by end customers and have been incorporated in their solutions.

4.2.1 Metal plate antenna applied in NEURON project

This metal plate antenna is also made of stainless steel and its default thickness is about 0.15mm, the substrate is made of FR4 and its dielectric constant is about 4.4. The following is the 3D structure of the antenna.

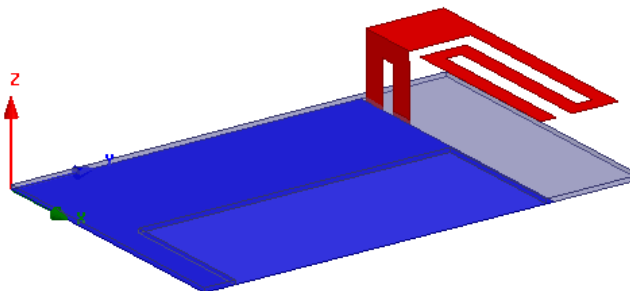

Figure 30 metal plate antenna in NEURON project 3D structure

In this figure, the red part is the metal plate antenna and the gray area is the cleared space on the PCB. The PCB board structure module is completely

compatible with the real PCB board. The dimension of this antenna is illustrated in the following figure. The position of the antenna on the PCB board marked “E” in the following figure is also very important and its value can affect the antenna resonance frequency.

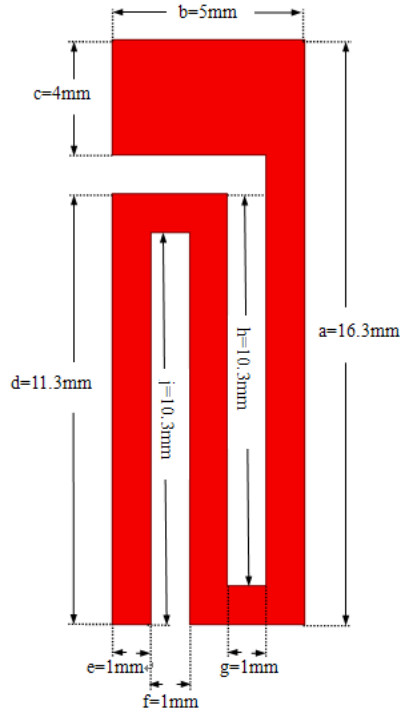

Figure 31 metal plate antenna in NEURON project dimension(1)

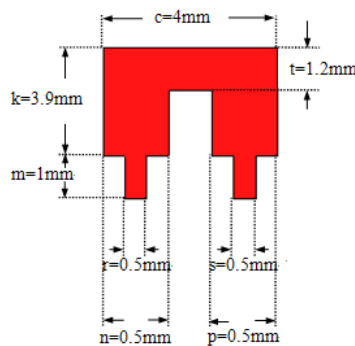

Figure 32 metal plate antenna in NEURON project dimension (2)

The dimension of the PCB board is illustrated in the following figure.

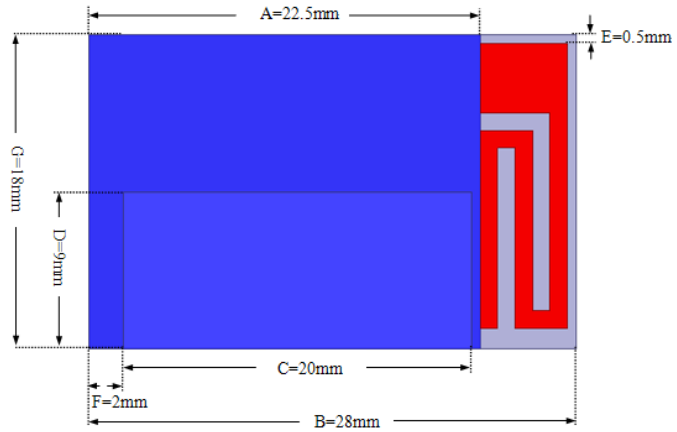

Figure 33 metal plate antenna in NEURON project motherboard dimension

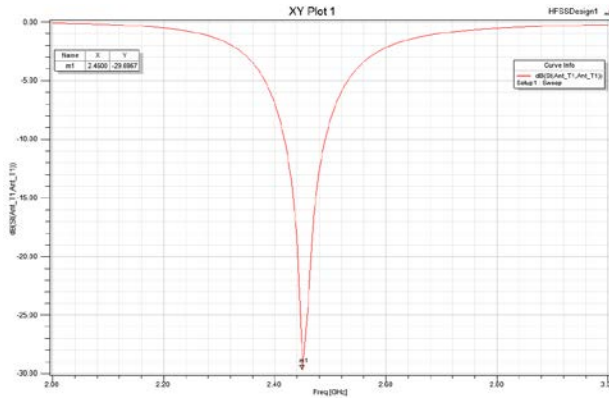

Figure 34 metal plate antenna in NEURON project S11 performance

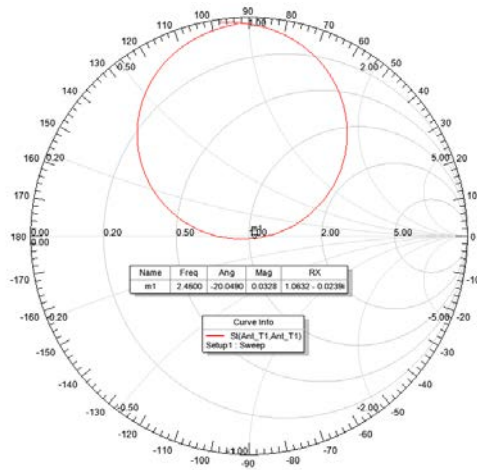

Figure 35 metal plate antenna in NEURON project Smith chart

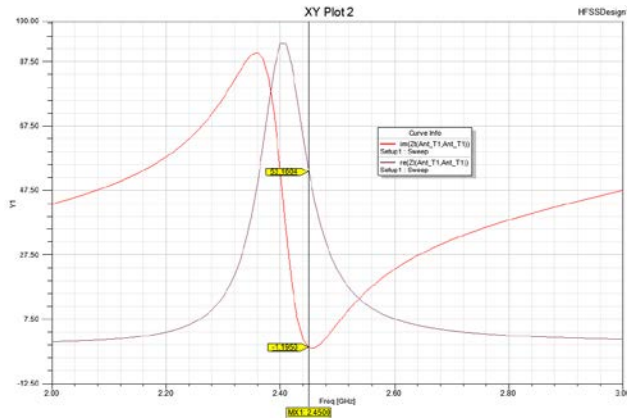

Figure 36 metal plate antenna in NEURON project input impedance characteristic

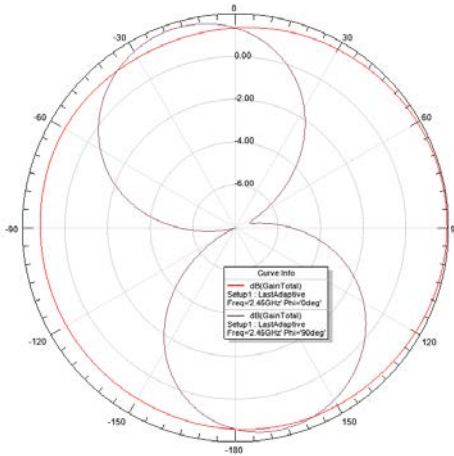

Figure 37 metal plate antenna in NEURON project EH plane gain characteristic

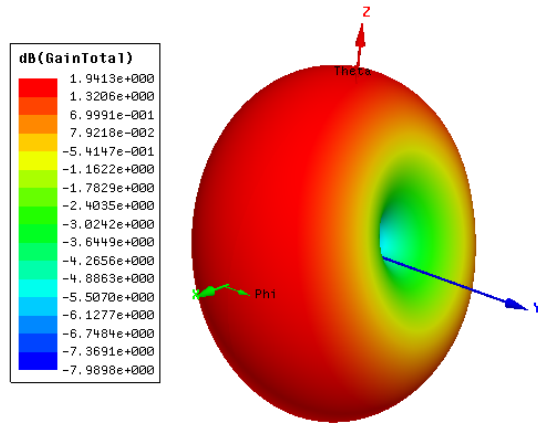

Figure 38 metal plate antenna in NEURON project 3D radiation pattern

Table 5 Effect on performance when critical parameters are altered

Antenna dimension	Change	parameter	effect
a	Increase	Resonance frequency	Decrease
		Bandwidth	Becomes narrow
	Decrease	Resonance frequency	Increase
		Bandwidth	Becomes wide
b	Increase	Resonance frequency	Increase
		Bandwidth	Becomes wide
	Decrease	Resonance frequency	Decrease
		Bandwidth	Becomes narrow
c	Increase	Resonance frequency	Decrease
		Bandwidth	Becomes narrow
	Decrease	Resonance frequency	Increase
		Bandwidth	Becomes wide
e	Increase	Resonance frequency	Decrease
		Bandwidth	Becomes narrow
	Decrease	Resonance frequency	Increase
		Bandwidth	Becomes wide
k	Increase	Resonance frequency	Increase
		Bandwidth	Becomes wide
	Decrease	Resonance frequency	Decrease

		Bandwidth	Becomes narrow
E	Increase	Resonance frequency	Increase
		Bandwidth	Becomes wide
	Decrease	Resonance frequency	Decrease
		Bandwidth	Becomes narrow

4.2.2 Metal plate antenna used in iCoin project

The antenna was used in the iCoin project, which is also made of stainless steel and the default thickness is about 0.15mm. This antenna shows better radiation performance during field test compared with the micro-strip antenna and chip antenna in the same conditions. The following figure illustrates the antenna’s 3D structure. The red part is the metal plate antenna and the pea green area is the clearance area on the PCB.

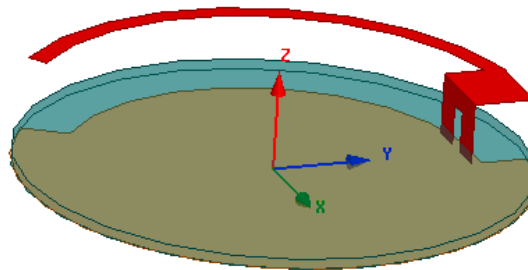

Figure 39 metal plate in iCoin project 3D structure

This antenna is also a kind of IFA .Its resonance frequency and radiation performance is not only dependant on its dimension but also that of the PCB. As mentioned in the previous part of this document, the clearance area is critical to the design. It is strongly recommended that a significant clearance space is used in the design. The following figure shows the dimensions of the antenna.

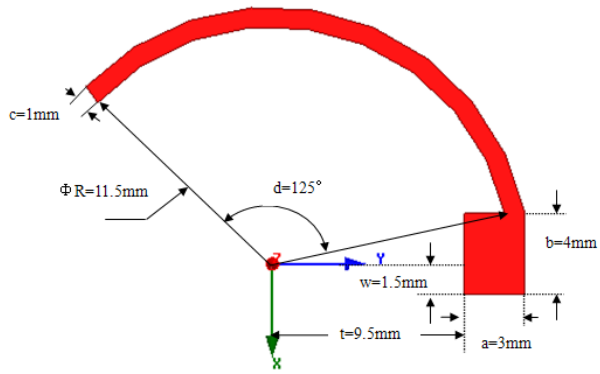

Figure 40 metal plate in iCoin project dimension (1)

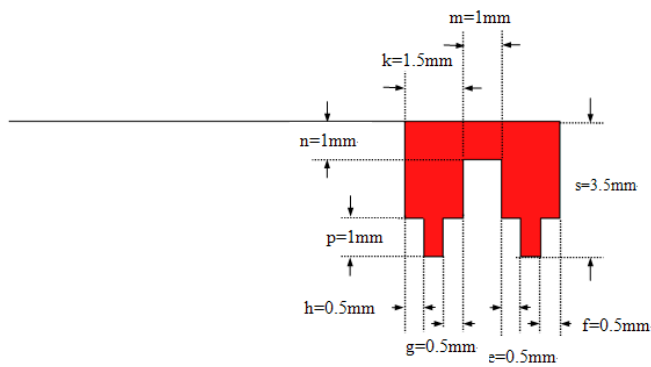

Figure 41 metal plate in iCoin project dimension (2)

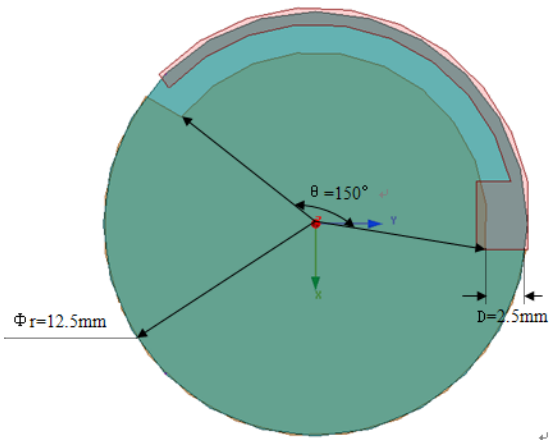

Figure 42 metal plate in iCoin project motherboard dimension

In this figure, the antenna is shown to be transparent in order to mark the cleaning space area dimension conveniently.

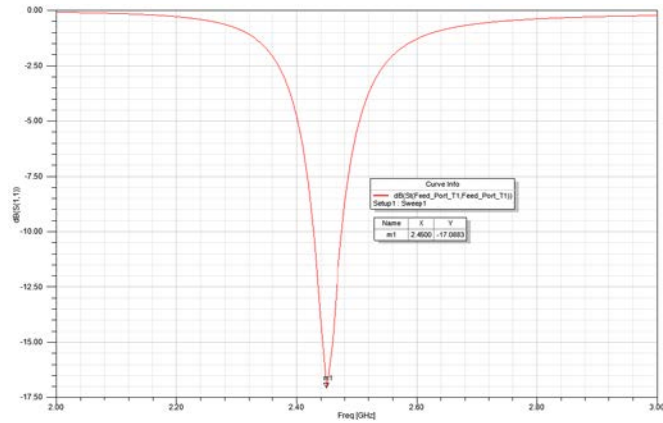

Figure 43 metal plate in iCoin project S11 performance

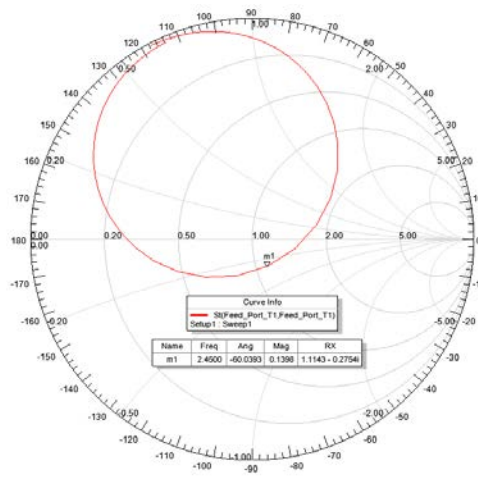

Figure 44 metal plate in iCoin project Smith chart

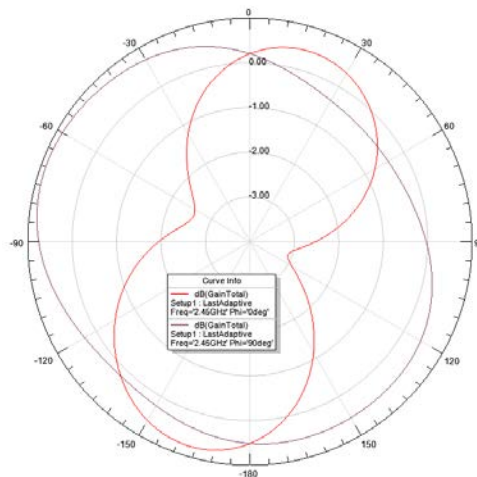

Figure 45 metal plate in iCoin project EH plane gain characteristic

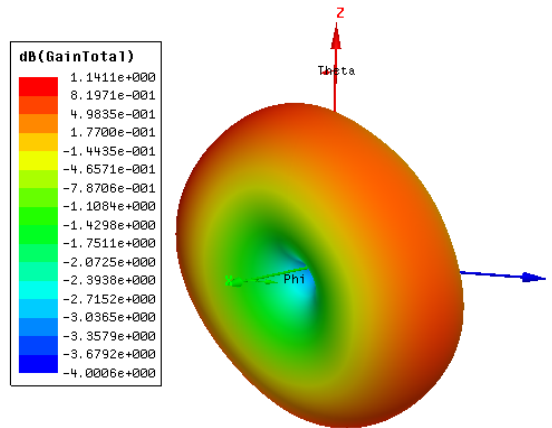

Figure 46 metal plate in iCoin project 3D radiation pattern

Table 6 Effect on performance when critical parameters are altered

Antenna dimension	change	parameter	effect
a	Increase	Resonance frequency	Decrease
		Bandwidth	Becomes narrow
	Decrease	Resonance frequency	Increase
		Bandwidth	Becomes wide
b	Increase	Resonance frequency	Unchanged
		Bandwidth	Becomes narrow
	Decrease	Resonance frequency	Unchanged
		Bandwidth	Becomes wide
c	Increase	Resonance frequency	Increase
		Bandwidth	Becomes narrow
	Decrease	Resonance frequency	Decrease
		Bandwidth	Becomes wide
d	Increase	Resonance frequency	Decrease
		Bandwidth	Becomes narrow
	Decrease	Resonance frequency	Increase
		Bandwidth	Becomes wide
s	Increase	Resonance frequency	Unchanged
		Bandwidth	Becomes wide
	Decrease	Resonance frequency	Unchanged





		Bandwidth	Becomes narrow
r	Increase	Resonance frequency	Decrease
		Bandwidth	Becomes wide
	Decrease	Resonance frequency	Increase
		Bandwidth	Becomes narrow
θ	Increase	Resonance frequency	Increase
		Bandwidth	Becomes wide
	Decrease	Resonance frequency	Decrease
		Bandwidth	Becomes narrow





5. Chip antenna

Chip antenna is usually supplied by professional manufacturer and is applied very conveniently by the users. With some key features such as very small size, lower cost and ease of use, chip antenna is widely used in various wireless applications, such as, WIFI, Bluetooth, etc. In the application process, the user is required to design good feed line, matching net and PCB structure to meet chip antenna performance requirement. The manufacturer often supplies chip antenna application note document as a reference for the user. In this section, some antenna vendors along with their product part numbers are presented for easy reference.

5.1 List of chip antenna suppliers

Table 7 chip antenna supplier list

Supplier	Test	Main 2.4G chip antenna products
	Y	AN3216, AN2051, AN6520, AN0835, AN9520
	Y	RFANT5220110AT, RFANT3216120AT, RFECA3216060A1T, RGANT8010100A0T, RFGFRA9937380A3T, RGFR A1903041A1T
	Y	BTCA5020, BTCA4020, BTCA1206, BTCA0805
	N	KTDA72-2R470G-S1, KTDA31-2R470G-S1, KTDA22-2R470G-S1, KTDA21-2R470G-S1,

	Y	2450AT18B100,2450AT18A100,2450AT18D0100,2450AT18E0100,2450AT43D100,2450AT43H0100,2450AT45A100
	Y	A10192,A5839,A5645,A6111,A6150,A10381
	N	W3001,W3008,W3008C,W3108
	N	FR05-S1-N-0-001,FR05-S1-N-0-104,FR05-S1-N-0-102,FR05-S1-N-0-110

5.2 Some of typical products by these suppliers

Table 8 RAINSON chip antenna product list

Part number	AN3216	AN2051	AN6520	AN0835	AN9520
Size	3.2mm (L)x 1.6mm(W) x 1.04mm(H)	5.05mm (L)x 2.0mm(W) x 1.07mm(H)	6.5mm (L)x 2.2mm(W) x 1.0mm(H)	8.0mm (L)x 3.5mm(W) x 1.0mm(H)	9.5mm (L)x 2.1mm(W) x 1.0mm(H)
Center frequency	2.45GHz	2.45GHz	2.45GHz	2.45GHz	2.45GHz
Peak gain	0.5dBi(typ.)	0.5dBi(typ.)	0.5dBi(typ.)	1dBi(typ.)	1.5dBi(typ.)
Operation temperature	-40~+85°C	-40~+85°C	-40~+85°C	-40~+85°C	-40~+85°C
Storage temperature	-40~+85°C	-40~+85°C	-40~+85°C	-40~+85°C	-40~+85°C
VSWR	2.5(max)	2.5(max)	2.5(max)	2(max)	2(max)
Input impedance	50 Ω	50 Ω	50 Ω	50 Ω	50 Ω
Power handling	1W	2W	1W	3W	3W
Bandwidth	110MHz(typ.)	110MHz(typ.)	110MHz(typ.)	180MHz(typ.)	200MHz(typ.)
Azimuth beam width	Omnidirectional	Omnidirectional	Omnidirectional	Omnidirectional	Omnidirectional
polarization	linear	linear	linear	linear	linear

Table 9 PSA chip antenna product list

Part number	RFANT522011 0AT	RFECA3216060 A1T	RGANT8010100 A0T	RFGFRA9937380 A3T
Size	5.2mm(L) x 2.0mm(W) x 1.1mm(H)	3.2mm(L) x 1.6mm(W) x 0.6mm(H)	8.0mm(L) x 1.0mm(W) x 1.0mm(H)	9.9mm(L) x 3.7mm(W) x 3.8mm(H)
Frequency range	2.4~2.5GHz	2.4G~2.835GHz	2.4~2.5GHz	2.4~2.5GHz
gain	2dBi(typ.)	2dBi(typ.)	2dBi(typ.)	2dBi(typ.)
VSWR	2(max)	2(max)	2(max)	2(max)
polarization	linear	linear	linear	linear
Azimuth beam width	Omni-directional	Omni-directional	Omni-directional	Omni-directional
Input impedance	50 Ω	50 Ω	50 Ω	50 Ω
Rated Power	3W		2W	1W
Maximum input power	5W for 5 minutes	5W for 5 minutes	5W for 5 minutes	

Table 10 CHENGDIAN electronic chip antenna product list

Part number	BTCA5020	BTCA4020	BTCA1206	BTCA0805	
Size	5.0mm(L) x 2.0mm(W) x 0.5mm (H)	4.0mm(L) x 2.0mm(W) x 1.2mm (H)	3.0mm(L) x 1.5mm(W) x 0.9mm (H)	2.0mm(L) x 1.2mm(W) x 0.85mm (H)	
Center frequency	2.45GHz	2.45GHz	2.45GHz	2.45GHz	
Peak gain	2dBi(typ.)	2dBi(typ.)	2dBi(typ.)	1dBi(typ.)	
VSWR	2	2	2	2	
Input impedance	50 Ω	50 Ω	50 Ω	50 Ω	
Azimuth beam width	Omni-directional	Omni-directional	Omni-directional	Omni-directional	
polarization	linear	linear	linear	linear	

Table 11 JOHANSON chip antenna product list

Part number	2450AT18B100	2450AT18A100	2450AT18D0100	2450AT18E0100	2450AT43D100
Size	3.2mm (L)x 1.6mm(W) x 1.3mm(H)	3.2mm (L)x 1.6mm(W) x 1.3mm(H)	3.2mm (L)x 1.6mm(W) x 1.2mm(H)	3.2mm (L)x 1.6mm(W) x 1.2mm(H)	6.0mm (L)x 2.5mm(W) x 2.0mm(H)
Center frequency	2.45GHz	2.45GHz	2.45GHz	2.45GHz	2.45GHz
Peak gain	0.5dBi(typ.)	0.5dBi(typ.)	1.5dBi(typ.)	1.0dBi(typ.)	-0.5dBi(typ.)
Average gain	-0.5dBi(typ.)	-0.5dBi(typ.)	-1.0dBi(typ.)	-3.0dBi(typ.)	-3.6dBi(typ.)
Operation temperature	-40~+85°C	-40~+85°C	-40~+85°C	-40~+85°C	-40~+85°C
Storage temperature	-40~+85°C	-40~+85°C	-40~+85°C	-40~+85°C	-40~+85°C
Return Loss	9.5dB(min)	9.5dB (min)	6dB(min)	4.4dB (min)	9.5dB (min)
Input impedance	50 Ω	50 Ω	50 Ω	50 Ω	50 Ω
Power handling	3W(max)	3W(max)	2W(max)	2W max	3W max
Bandwidth	100MHz(typ.)	100MHz(typ.)	100MHz(typ.)	100MHz(typ.)	100MHz(typ.)
polarization	linear	linear	linear	linear	linear

Table 12 ANTENOVA chip antenna product list

Part number	A10192	A5839	A5645	A6111	A6150
Size	4.0mm(L) x 3.0mm(W) x 1.1mm(H)	12.8mm(L) x 3.9mm(W) x 1.1mm(H)	20.5mm(L) x 3.6mm(W) x 3.3mm(H)	12.8mm(L) x 3.6mm(W) x 3.3mm(H)	6.1mm(L) x 3.9mm(W) x 1.1mm(H)
Frequency range	2.4~2.5GHz	2.4~2.5GHz	2.4~2.5GHz	2.4~2.5GHz	2.4~2.5GHz
efficiency	65%	75%	65%	45%	65%
Peak gain	0.8dBi	2.1dBi	-	-	-
Average gain	-1.9dBi	-1.2dBi	-	-	-

Radiation pattern	Omni-directional	Omni-directional	Omni-directional	Omni-directional	Omni-directional
VSWR	2(max)	1.8(max)	1.8(max)	2.3(max)	1.9(max)
Input impedance	50 Ω	50 Ω	50 Ω	50 Ω	50 Ω
polarization	linear	linear	linear	linear	linear

5.3 Placement of chip antenna on PCB

How to layout the chip antenna on the PCB is a very important. The antenna position on PCB board, the size of cleaning space area and the distance between the antenna and reference ground plane will affect the antenna resonance frequency and impedance. In this part, some typical solutions will be described.

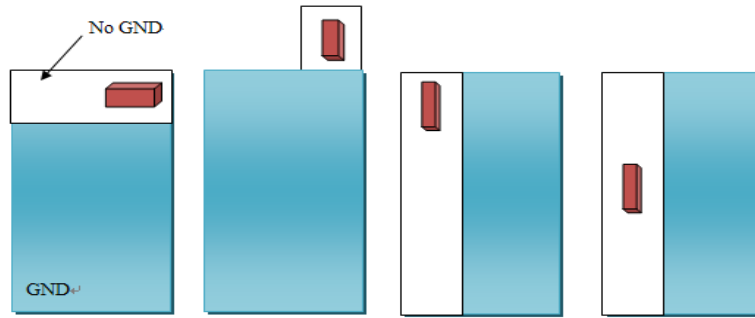

Figure 47 excellent cases for chip antenna placement

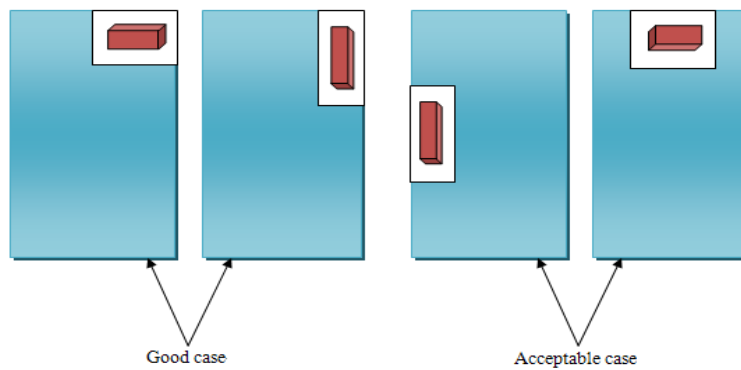

Figure 48 good and acceptable cases for chip antenna placement

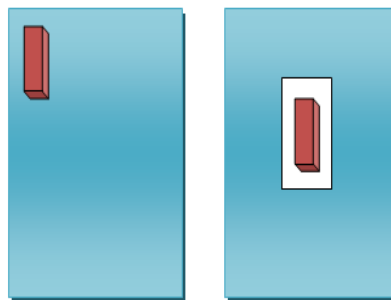

Figure 49 not-recommended cases for chip antenna placement

6. Test Procedure for antenna

In this section, the 2.4GHz antenna test procedure will be introduced. Antenna test procedure including network analyzer calibration, RL(return loss) measurement, input impedance measurement, and bandwidth measurement.

6.1 Network analyzer calibration

Before measuring the antenna, the network analyzer must be calibrated; otherwise the measuring result will be incorrect. The network analyzer should be calibrated in a suitable frequency range containing the band where the antenna will operate. Some new network analyzer can support automatic calibration, older versions require manual calibration. After calibrating, the reference plane moves to the calibration port.

Please refer to the Network Analyzer user guide to perform the above mentioned calibration.

Ferrite can be used to reduce the influence from leakage currents. PCB boards which have a ground plane with dimensions that are a fraction of wavelength tend to have larger currents running on the ground plane. This could potentially cause unstable results when trying to measure the reflection at the feed point of antenna. The placement of the ferrite along the cable will also affect the result, so it is necessary to understand that there is a certain inaccuracy when performing this kind of measurement.

The port extension function is used to move the reference plane from the calibration port to the expected plane. Once port extension function is opened by pressing the Port extension button, the reference plane can be moved by tuning the delay time parameter. For more detail information can refer to related user manual document.

6.2 Measurement of antenna Return Loss, Impedance and Bandwidth

A 50 Ohm cable is used in order to measure the return loss at the antenna port.

One end of this cable should be soldered to a SMA connector and another end should be soldered to the antenna feed point. The antenna feed port should be disconnected from the antenna feed line when the measurement is performed.

The unshielded inner of the cable should be as short as possible to reduce the parasitic inductance which can cause inaccurate measurements. The outer shield of the cable should be soldered to the reference ground plane as close as possible to the end of the cable to keep the continuity of cable impedance.

According to the RF theory, return loss is only dependent on the absolute value of the reflection efficiency, so it is unnecessary to move reference plane from the calibration point to the antenna feed point. But for Impedance measurement this

is not true and therefore the reference plane should be moved to the antenna feed point, thus avoiding any errors in the measurement.

The manner of antenna placement will affect the measurement result. So, the antenna should be kept in the same manner as it is going to be used in the application. To get higher accuracy of the measurement, the real performance should be placed inside a final casing where the antenna will be used. If the antenna is used by one handheld device, the device should be positioned in a hand to measure the performance. Even if the antenna is designed to be used in a special environment, it may be necessary to measure the antenna in free space. To show how much the body, the plastic shell will affect the antenna performance, additional measurement could be needed. During the measurement, the antenna should not be placed close to other objects, especially close to radiator. The network analyzer metal front-plate could also affect the measuring result because it can be seemed to be one reflective surface, and it will affect the directional characteristics and radiation pattern of antenna, so the antenna should be situated as far away as possible to the metal front-plate.

6.3 Description of the measurement result

The antenna is often seemed as a 1-port component during measurement. So, one port of the network analyzer is enough for measuring the return loss (S_{11}), impedance and VSWR. In some cases like measuring S_{21} , 2 ports are needed. As an example, the following figure illustrates the result of S_{11} measurement.

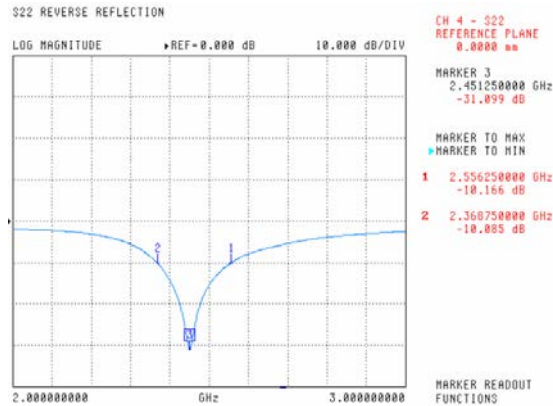

Figure 50 antenna S11 performance measured by network analyzer

In the total operating frequency range, S11 is required to be less than -10dB. In above figure, the antenna S11 is lower than -31dB at the resonance frequency point 2.45 GHz and the 10dB bandwidth is about 190MHz. The impedance can be illustrated by the Smith Chart, which is showed in the following figure.

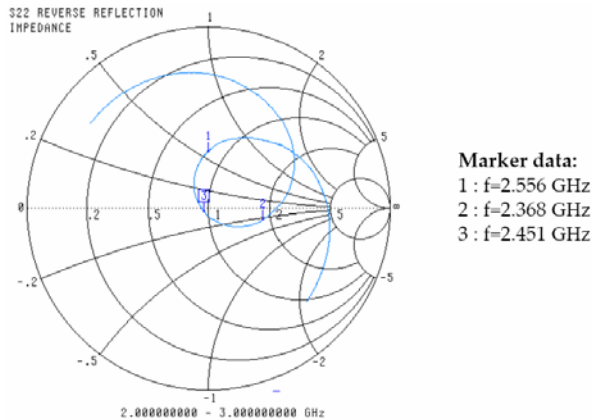

Figure 51 antenna Smith chart measured by network analyzer

Generally, the impedance can be measured to see what kind of matching net is needed to achieve better performance for antenna. In the above figure, return loss curve, with the frequency range of 2.368GHz to 2.556GHz, is in the VSWR circle, which the radius is lower than 2. So, it is unnecessary to add matching net to this antenna to improve its performance.

6.4 How to design matching net for antenna

In order to achieve better performance, it is standard practice to add pads for a Pi, T or L impedance matching network. Alternately, micro-strip matching structures can also be designed on the board. In this section, only lumped

element matching net is described. Matching net is used in case S11 at resonance frequency point does not meet the requirement, though the antenna resonates at the correct frequency.

There are several factors that can affect the antenna resonance frequency, such as, the dimension of antenna itself, the size of reference ground, the distance between antenna and ground, the position of the feed point. If varying these factors can not improve the performance enough, a matching network should be added between the PCB and the antenna. Inductor and capacitor in series or parallel can be used to construct the matching net to improve antenna S11 parameter. A Smith Chart can be used to determine the approximate values of the matching network components.

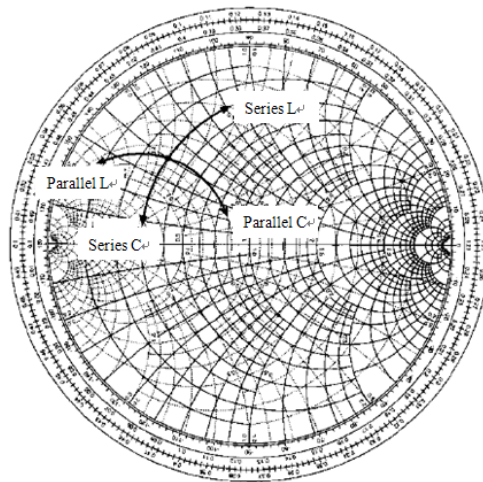

Figure 52 typical lump component characteristic in Smith chart

Various RF CAD tools can be used to design the matching network, in order to ease the design process.

7. Legal information

7.1 Definitions

Draft — The document is a draft version only. The content is still under internal review and subject to formal approval, which may result in modifications or additions. NXP Semiconductors does not give any representations or warranties as to the accuracy or completeness of information included herein and shall have no liability for the consequences of use of such information.

7.2 Disclaimers

Limited warranty and liability — Information in this document is believed to be accurate and reliable. However, NXP Semiconductors does not give any representations or warranties, expressed or implied, as to the accuracy or completeness of such information and shall have no liability for the consequences of use of such information. NXP Semiconductors takes no responsibility for the content in this document if provided by an information source outside of NXP Semiconductors.

In no event shall NXP Semiconductors be liable for any indirect, incidental, punitive, special or consequential damages (including - without limitation - lost profits, lost savings, business interruption, costs related to the removal or replacement of any products or rework charges) whether or not such damages are based on tort (including negligence), warranty, breach of contract or any other legal theory.

Notwithstanding any damages that customer might incur for any reason whatsoever, NXP Semiconductors' aggregate and cumulative liability towards customer for the products described herein shall be limited in accordance with the *Terms and conditions of commercial sale* of NXP Semiconductors.

Right to make changes — NXP Semiconductors reserves the right to make changes to information published in this document, including without limitation specifications and product descriptions, at any time and without notice. This document supersedes and replaces all information supplied prior to the publication hereof.

Suitability for use — NXP Semiconductors products are not designed, authorized or warranted to be suitable for use in life support, life-critical or safety-critical systems or equipment, nor in applications where failure or malfunction of an NXP Semiconductors product can reasonably be expected to result in personal injury, death or severe property or environmental damage. NXP Semiconductors and its suppliers accept no liability for inclusion and/or use of NXP Semiconductors products in such equipment or applications and therefore such inclusion and/or use is at the customer's own risk.

Applications — Applications that are described herein for any of these products are for illustrative purposes only. NXP Semiconductors makes no representation or warranty that such applications will be suitable for the specified use without further testing or modification.

Customers are responsible for the design and operation of their applications and products using NXP Semiconductors products, and NXP Semiconductors accepts no liability for any assistance with applications or customer product design. It is customer's sole responsibility to determine

whether the NXP Semiconductors product is suitable and fit for the customer's applications and products planned, as well as for the planned application and use of customer's third party customer(s). Customers should provide appropriate design and operating safeguards to minimize the risks associated with their applications and products.

NXP Semiconductors does not accept any liability related to any default, damage, costs or problem which is based on any weakness or default in the customer's applications or products, or the application or use by customer's third party customer(s). Customer is responsible for doing all necessary testing for the customer's applications and products using NXP Semiconductors products in order to avoid a default of the applications and the products or of the application or use by customer's third party customer(s). NXP does not accept any liability in this respect.

Export control — This document as well as the item(s) described herein may be subject to export control regulations. Export might require a prior authorization from competent authorities.

Translations — A non-English (translated) version of a document is for reference only. The English version shall prevail in case of any discrepancy between the translated and English versions.

Evaluation products — This product is provided on an "as is" and "with all faults" basis for evaluation purposes only. NXP Semiconductors, its affiliates and their suppliers expressly disclaim all warranties, whether express, implied or statutory, including but not limited to the implied warranties of non-infringement, merchantability and fitness for a particular purpose. The entire risk as to the quality, or arising out of the use or performance, of this product remains with customer.

In no event shall NXP Semiconductors, its affiliates or their suppliers be liable to customer for any special, indirect, consequential, punitive or incidental damages (including without limitation damages for loss of business, business interruption, loss of use, loss of data or information, and the like) arising out of the use of or inability to use the product, whether or not based on tort (including negligence), strict liability, breach of contract, breach of warranty or any other theory, even if advised of the possibility of such damages.

Notwithstanding any damages that customer might incur for any reason whatsoever (including without limitation, all damages referenced above and all direct or general damages), the entire liability of NXP Semiconductors, its affiliates and their suppliers and customer's exclusive remedy for all of the foregoing shall be limited to actual damages incurred by customer based on reasonable reliance up to the greater of the amount actually paid by customer for the product or five dollars (US\$5.00). The foregoing limitations, exclusions and disclaimers shall apply to the maximum extent permitted by applicable law, even if any remedy fails of its essential purpose.

7.3 Trademarks

Notice: All referenced brands, product names, service names and trademarks are property of their respective owners.

<Name> — is a trademark of NXP Semiconductors N.V.

8. List of figures

No table of figures entries found.

Figure 1 "L" antenna dimension	6	Figure 36 metal plate antenna in NEURON project input impedance characteristic.....	25
Figure 2 "L" antenna 3D structure.....	7	Figure 37 metal plate antenna in NEURON project EH plane gain characteristic.....	25
Figure 3 "L" antenna S11 performance.....	7	Figure 38 metal plate antenna in NEURON project 3D radiation pattern	26
Figure 4 "L" antenna Smith chart.....	8	Figure 39 metal plate in iCoin project 3D structure	27
Figure 5 "L" antenna EH plane gain characteristic.....	8	Figure 40 metal plate in iCoin project dimension (1)	28
Figure 6 "L" antenna 3D radiation pattern.....	8	Figure 41 metal plate in iCoin project dimension (2)	28
Figure 7 Bow shaped antenna dimension.....	9	Figure 42 metal plate in iCoin project motherboard dimension.....	28
Figure 8 Bow shaped antenna 3D structure.....	10	Figure 43 metal plate in iCoin project S11 performance ...	29
Figure 9 Bow shaped antenna S11 performance.....	10	Figure 44 metal plate in iCoin project Smith chart.....	29
Figure 10 Bow shaped antenna Smith chart.....	10	Figure 45 metal plate in iCoin project EH plane gain characteristic.....	29
Figure 11 Bow shaped antenna EH plane gain characteristic.....	11	Figure 46 metal plate in iCoin project 3D radiation pattern.....	30
Figure 12 Bow shaped antenna 3D radiation pattern.....	11	Figure 47 excellent cases for chip antenna placement	36
Figure 13 circularly polarized antenna structure	12	Figure 48 good and acceptable cases for chip antenna placement.....	36
Figure 14 circularly polarized antenna dimension.....	13	Figure 49 not-recommended cases for chip antenna placement.....	36
Figure 15 circularly polarized antenna 3D structure.....	13	Figure 50 antenna S11 performance measured by network analyzer.....	39
Figure 16 circularly polarized antenna S11 performance..	13	Figure 51 antenna Smith chart measured by network analyzer.....	39
Figure 17 circularly polarized antenna Smith chart	14	Figure 52 typical lump component characteristic in Smith chart	40
Figure 18 circularly polarized antenna axial ratio characteristic (1)	14		
Figure 19 circularly polarized antenna axial ratio characteristic (2)	14		
Figure 20 IFA antenna dimension	15		
Figure 21 IFA antenna 3D structure.....	15		
Figure 22 IFA antenna PCB layout	16		
Figure 23 IFA antenna S11 performance.....	18		
Figure 24 IFA antenna Smith chart	18		
Figure 25 IFA antenna EH plane gain characteristic.....	19		
Figure 26 IFA antenna 3D radiation pattern.....	19		
Figure 27 IFA antenna axial ratio performance.....	19		
Figure 28 IFA antenna current amplitude distribution	20		
Figure 29 Metal plate antenna 3D structure.....	22		
Figure 30 metal plate antenna in NEURON project 3D structure.....	22		
Figure 31 metal plate antenna in NEURON project dimension(1)	23		
Figure 32 metal plate antenna in NEURON project dimension (2)	23		
Figure 33 metal plate antenna in NEURON project motherboard dimension	24		
Figure 34 metal plate antenna in NEURON project S11 performance.....	24		
Figure 35 metal plate antenna in NEURON project Smith chart.....	25		

9. List of tables

Table 1 Typical BLE antennas comparing4

Table 2 Effect on performance when critical dimensions are altered.....9

Table 3 Effect on performance when critical dimensions are altered..... 11

Table 4 Effect on performance when critical parameters are altered.....20

Table 5 Effect on performance when critical parameters are altered.....26

Table 6 Effect on performance when critical parameters are altered.....30

Table 7 chip antenna supplier list31

Table 8 RAINSON chip antenna product list.....32

Table 9 PSA chip antenna product list.....33

Table 10 CHENGDIAN electronic chip antenna product list33

Table 11 JOHANSON chip antenna product list34

Table 12 ANTENOVA chip antenna product list34