

PCA9534/35

8 and 16-bit I²C and SMBus Low Power I/O Port with Interrupt

The PCA9534/35 enhance the Philips family of I²C I/O expanders with a low power option of the PCA9554/55 to maximize battery life in battery powered applications.

Pin Configurations

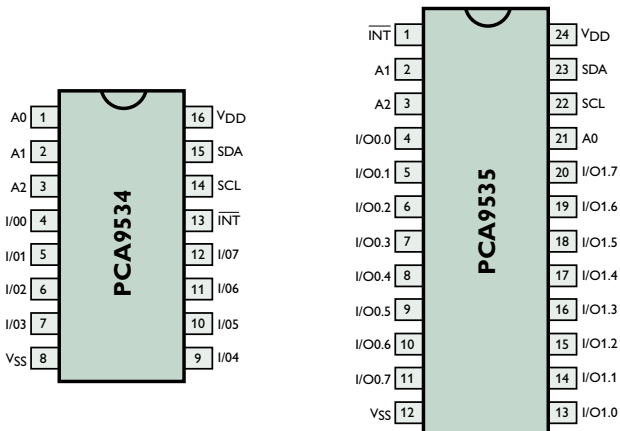

I²C Address

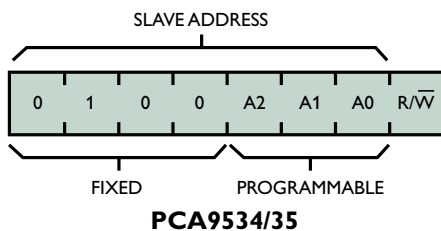

Features

- I²C and SMBus compatible
- 8 or 16 programmable I/Os compatible with most processors
 - Input or output
 - Push-Pull outputs
 - True bi-directional style I/O
- Outputs can directly drive LEDs
 - 25 mA max sink and 10 mA max source per bit
 - Capacity of 100 mA max per 8-bit register
- Open-drain interrupt output activated when input changes state
- Low I_{DD} standby current of 1 μA max
- Offered in SOWide (D), TSSOP (PW) and HVQFN (BS) packages
- Manufactured in a high-volume CMOS process

Operating Characteristics

- 2.3 V to 5.5 V operating voltage
- 5.5 V tolerant I/Os
- -40 °C to 85 °C operating temperature range
- 0 Hz to 400 kHz clock frequency



Description

The PCA9534 is a 16-pin CMOS device and the PCA9535 is a 24-pin CMOS device that provide General Purpose parallel Input/Output (GPIO) expansion. The PCA9534 has an 8-bit Configuration register (Input or Output selection), 8-bit Input register, 8-bit Output register and an 8-bit Polarity inversion register (Active high or Active low operation) that allows the system master to program and configure 8 GPIOs through the I²C bus. The PCA9535 has 16 GPIOs and contains two sets of the same 8-bit registers as the PCA9534. These I/O expanders provide a simple solution when additional I/Os are needed for battery powered I²C/SMBus applications such as sensors, pushbuttons, LEDs, fans, etc.. The PCA9534/35 are identical to the PCA9554/55 I/O expanders except for a very low standby current that is less than 1 μA, to maximize battery life in battery powered applications.

The system master can enable the PCA9534/35 I/Os as either inputs or outputs by writing to the I/O configuration bits. The data for each Input or Output is kept in the corresponding Input or Output register. The polarity of the read register can be inverted with the Polarity Inversion Register. All registers can be read by the system master. Although pin to pin and I²C address compatible with the PCF857X series, software changes are required to fill existing sockets due to the enhancements, discussed in Application Note AN469. The PCA9534/35 open-drain interrupt output is activated when any input state differs from its corresponding input port register state and is used to indicate to the system master that an input state has changed.

Three hardware pins (A0,A1,A2) vary the I²C address and allow any combination of up to eight of these devices to share the same I²C/SMBus.

Order Information

Package	Container	PCA9534	PCA9535
SO	Tube	PCA9534D	PCA9535D
	T & R	PCA9534D-T	PCA9535D-T
TSSOP	Tube	PCA9534PW	PCA9535PW
	T & R	PCA9534PW-T	PCA9535PW-T
HVQFN	T & R	PCA9534BS-T	PCA9535BS-T



PCA9534/35

8 and 16-bit I²C and SMBus Low Power I/O Port with Interrupt



Block Diagram

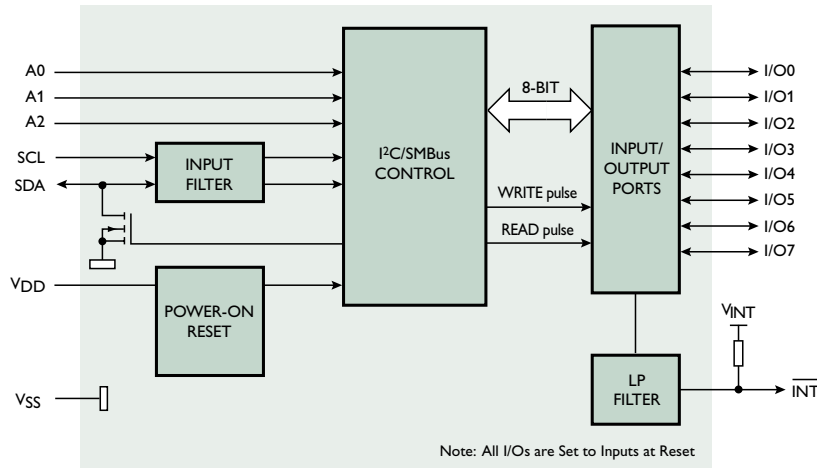

Simplified Schematic of I/O0 to I/O7

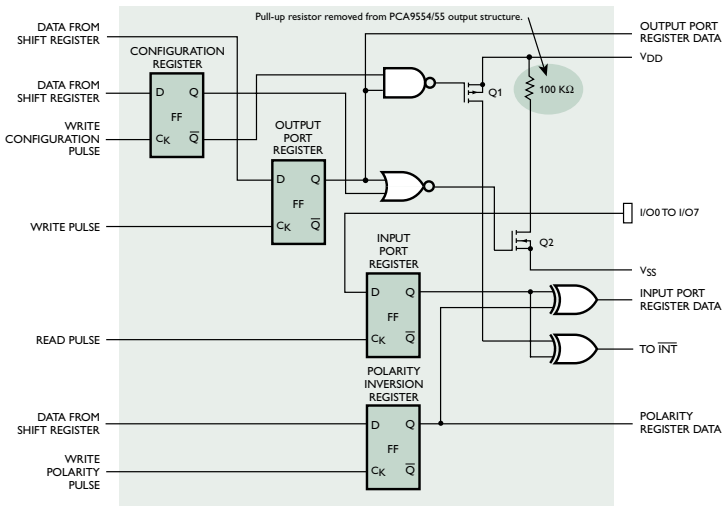

The PCA9534/35 functional diagram and I/O schematic are identical except that the PCA9535 has two 8-bit blocks of I/O.

The PCA9534/35 feature outputs that sink 25 mA and source 10 mA, and are identical to the PCA9554/54A/55 and 57. The PCA9534/35 are identical to the PCA9554/55 in all aspects except for the 100 K Ω pull-up resistor that has been removed to reduce the standby low current to <1 μ A for battery powered applications. This is the same low current as seen in the PCA9557.

www.semiconductors.philips.com/logic/i2c

Philips Semiconductors

Philips Semiconductors is a worldwide company with over 100 sales offices in more than 50 countries. For a complete up-to-date list of our sales offices please e-mail sales.addresses@www.semiconductors.philips.com.

A complete list will be sent to you automatically. You can also visit our website <http://www.semiconductors.philips.com/sales>

© Koninklijke Philips Electronics N.V. 2002

All rights reserved. Reproduction in whole or in part is prohibited without the prior written consent of the copyright owner. The information presented in this document does not form part of any quotation or contract, is believed to be accurate and reliable and may be changed without notice. No liability will be accepted by the publisher for any consequence of its use. Publication thereof does not convey nor imply any license under patent- or other industrial or intellectual property rights.



Purchase of Philips I²C components conveys a license under the Philips' patent to use the components in the I²C system provided the system conforms to the I²C specification defined by Philips.



Date of release: August 2002
document order number: 9397 750 10197

Published in U.S.A.