

PCK2022RA/PCK2057 PCK2002PL/PCK2509SL

Full Clocking Solution for ServerWorks Grand Champion™ System I/O Switch

System Block Diagram

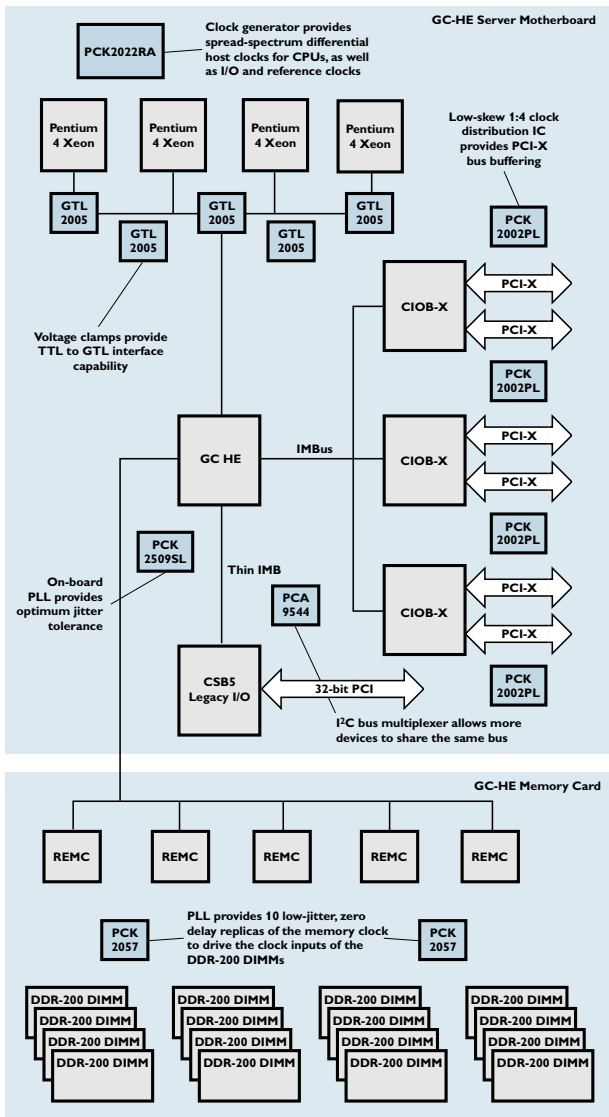

Description

Philips Semiconductors provides the full clocking solution for the Grand Champion™ System I/O Switch from ServerWorks, which supports Intel processors and DDR SDRAM technology. The clocking solution, consisting of the PCK2022RA clock generator, the PCK2057 differential memory driver, the PCK2509SL clock driver, and the PCK2002PL PCI-X buffer, supports computing platforms based on the ServerWorks Grand Champion GC-HE-4P (High End - 4 Processor) System I/O Switch, which utilizes the Xeon™ Processor from Intel, DDR memory and the PCI-X I/O bus.

On the motherboard, the PCK2022RA provides 8 precision time-aligned spread-spectrum differential host clocks for the CPUs, chipset and memory with very low jitter of 200 ps, and also generates a 14.318 MHz reference clock, two 48 MHz clocks, and an I/O clock at 33 or 66 MHz. The PCK2002PL provides 1:4 fan-out with low skew bus buffering for the PCI-X bus. The PCK2509SL generates a low-jitter replica of the GC-HE memory clock to drive the clock signal to the memory card.

On the memory card, the PCK2057 creates 10 low-jitter, zero-delay replicas of the memory clock to drive the clock inputs of the DDR DIMMs.

Additional devices featured on the Grand Champion platform are the PCA9544 4-channel I²C bus multiplexer, which allows multiple I²C devices with the same address to share the bus; and the GTL2005 which provides TTL (chipset) to 1.5V GTL (CPU side) voltage level shifting.

Applications

- High-performance multi-processor server systems with DDR-200 or DDR-266 memory technology

PCK2022RA

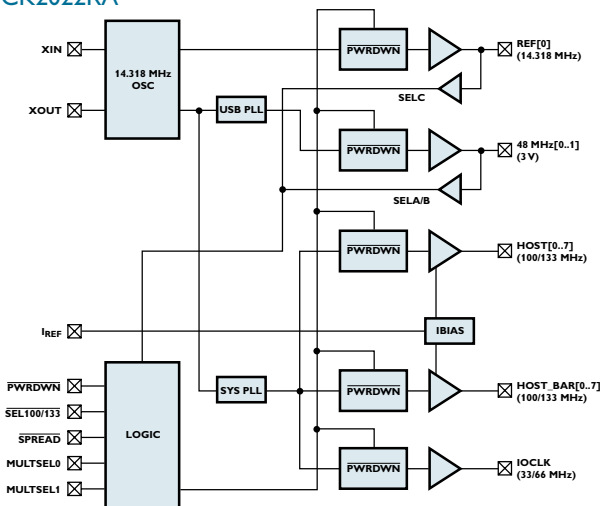

PCK2022RA

- Eight differential CPU clocks
- I/O clocks at 33 MHz and 66 MHz
- Two 3.3 V, 48 MHz clocks
- 14.318 MHz Reference Clock
- Optimized frequency and spread spectrum performance
- Host clock jitter < 200 ps cycle-to-cycle
- Host clock skew < 150 ps pin-to-pin
- Power management control pins
- 48-pin plastic TSSOP package



PCK2022RA/PCK2057/PCK2002PL/PCK2509SL

Full Clocking Solution for ServerWorks Grand Champion™ System I/O Switch

Functional Outlines and Features

PCK2057

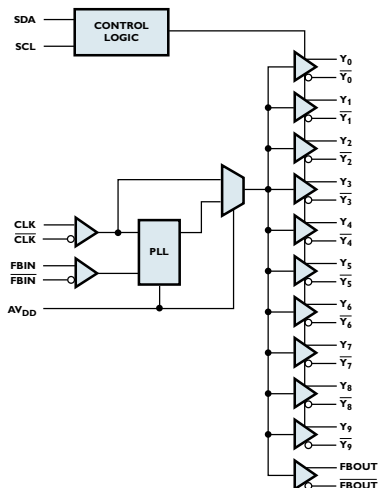

PCK2057

- 1:10 differential clock distribution
- Jitter < 100 ps
- HCSL to SSTL_2 input conversion
- 2.5 V and 3.3 V I²C support
- Test mode enables output buffers while disabling PLL
- Spread spectrum tolerant clock input
- 48-pin plastic TSSOP packaging

PCK2510SL

- As PCK2509SL but with single output enable for all ten outputs

PCK2002PL

- 1:4 fan-out ratio
- 3.3 V operation
- 0 – 400 MHz clock frequency
- 8-pin TSSOP Package (3.0 x 4.4 mm)

PCK2509SL

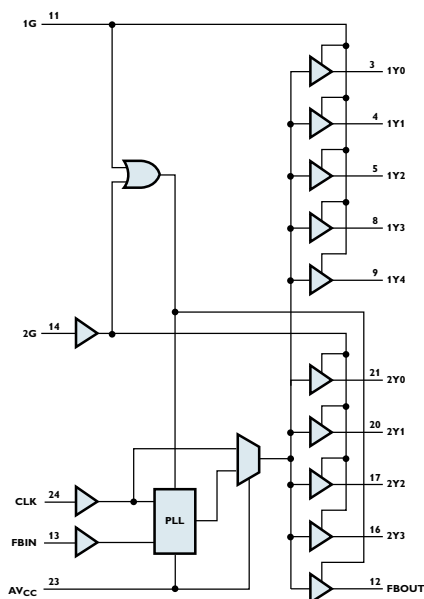

PCK2509SL

- 1:9 clock distribution ratio
- 50 – 167 MHz operation
- 3.3 V operation
- Low power standby operation
- Spread spectrum clock compatible
- Output enable per bank of five outputs
- 2.5 V / 3.3 V input compatible
- 24-pin TSSOP

PCK2002PL

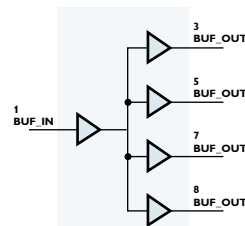

Ordering Information

Package	Container	PCK2022RA	PCK2057	PCK2002PL	PCK2509SL
TSSOP	Tube T & R	PCK2022RADGG PCK2022RADGG-T	PCK2057DGG PCK2057DGG-T	PCK2002PLPW PCK2002PLPW-T	PCK2509SLDH PCK2509SLDH-T

Family Overview

Part Number	Function
PCK2022RA	100/133 MHz Spread Spectrum Differential Clock Generator
PCK2057	70 - 190 MHz I ² C Differential 1:10 DDR Memory Clock Driver
PCK2509SL	50 - 167 MHz Spread-spectrum Compatible 1:9 Zero-Delay Buffer
PCK2002PL	4-bit 400 MHz 1:4 PCI-X Clock Buffer

Philips Semiconductors

Philips Semiconductors is a worldwide company with over 100 sales offices in more than 50 countries. For a complete up-to-date list of our sales offices please e-mail sales.addresses@www.semiconductors.philips.com.

A complete list will be sent to you automatically. You can also visit our website <http://www.semiconductors.philips.com/sales>

© Koninklijke Philips Electronics N.V. 2002

All rights reserved. Reproduction in whole or in part is prohibited without the prior written consent of the copyright owner. The information presented in this document does not form part of any quotation or contract, is believed to be accurate and reliable and may be changed without notice. No liability will be accepted by the publisher for any consequence of its use. Publication thereof does not convey nor imply any license under patent- or other industrial or intellectual property rights.

