

DVD+RW Recorder Reference Design

A proven reference design giving manufacturers of high-quality DVD+RW video recorders an aggressive head start bringing products to market. DVD+RW satisfies both consumer preference and the industry's appeal for a single standard for rewriteable digital video recording.



Key features

- Complete solution including hardware schematics, bill of materials, an industry-standard software stack, and documentation
- Based on the highly-integrated Nexperia PNX7100 MPEG-2 codec and VAE8020 video recorder engine
- Reference designs available for North America and Europe
- Supports record and playback of DVD+RW/+R formats; playback of DVD-V, DVD-R, CD, CD-R, CD-RW, CD-DA, VCD, SVCD formats
- 100% DVD+RW standard compliance maximizes compatibility with existing DVD/CD formats
- Video features: MPEG-2 MP@ML (playback and record); MPEG-1, DV (playback)
- Audio features: stereo AC-3, stereo MPEG-1 L2 (record); LPCM, stereo AC-3, stereo MPEG, DTS on SPDIF output (playback)
- Transcodes DV stream to MPEG-2 stream
- Supports popular playback and video editing features and consumer-friendly recording controls
- Tailorable front panel, user interface, and remote-control interface

Turnkey solution for DVD+RW/+R video recorders



The Philips Nexperia DVD+RW/+R Recorder Reference Design is a complete, turnkey solution for developing DVD+RW video recorders for worldwide markets. It includes validated hardware schematics, a bill of materials, and a complete software stack enabling manufacturers to build DVD+RW/+R recorders quickly at competitive price points. 100% compliant with the DVD+RW standard, the Reference Design is based on the highly integrated Philips Nexperia PNX7100 MPEG-2 codec and the Philips VAE8020 DVD+RW/+R recorder engine. It handles all record playback, control, power, and user interface functions using three boards (digital, analog, front panel) and a DVD+RW engine.

Digital board with Nexperia PNX7100 MPEG-2 codec

Digital board components work together to convert baseband video between analog and digital domains, decompress and compress digital video and audio data, control the analog and front panel board, and convert and switch power. The board is powered by a Nexperia PNX7100 MPEG-2 codec designed for audio/video recording products. Handling high-quality MPEG-2 encoding, MP@ML MPEG-2 decoding, and DV-to-MPEG-2 transcoding on a single chip, the PNX7100 reduces the bill of materials, cost, and development time.

DVD+RW Offering full compatibility with most existing DVD-Video players and DVD-ROM drives, DVD+RW is quickly becoming the popular consumer choice and the de facto industry standard for rewriteable digital video recording. Designed with low cost and ease-of-use in mind, the DVD+RW standard meets the picture quality requirements of both professional and consumer markets and is supported by leading PC and consumer electronics companies. Features inherent in the standard maximize compatibility with existing DVD and CD formats and offer consumer-friendly options such as on-disc editing, instant disc usability, improved defect management, and seamless error correction.

PHILIPS

DVD+RW Recorder Reference Design

Turnkey solution for DVD+RW/+R video recorders



The PNX7100's high-performance, 32-bit MIPS core runs a real-time operating system for control processing. When recording, PNX7100 works with an onboard video input processor, and an IEEE 1394 interface. An on-chip digital video encoder generates Macrovision copy protected analog outputs. For playback, the PNX7100 handles multi-standard audio decoding and audio post processing features such as Dolby® Pro Logic® decoding.

Analog board

The Reference Design's analog board handles RF tuning and video demodulation, RF loop-through from the antenna to the TV, and analog switching between all video and audio sources for the output path. It provides other functions such as analog/digital audio conversion and fan control.

Front panel board

The front panel board houses the remote control interface, key push-button interface, user display control functions (VFD), LED indicator controls, and functions driven by I²C and/or PIO controls.

DVD+RW recorder engine

A central building block for consumer DVD+RW recorders, the VAE8020 engine includes a fully assembled DVD+RW mechanism with dual laser optical pick-up unit (OPU), a tray loader with fan unit, a brushless disc motor, and a printed circuit board containing the electronics for module control and channel encoding/decoding.

DVD+RW/+R Recorder Reference Design Functional Block Diagram

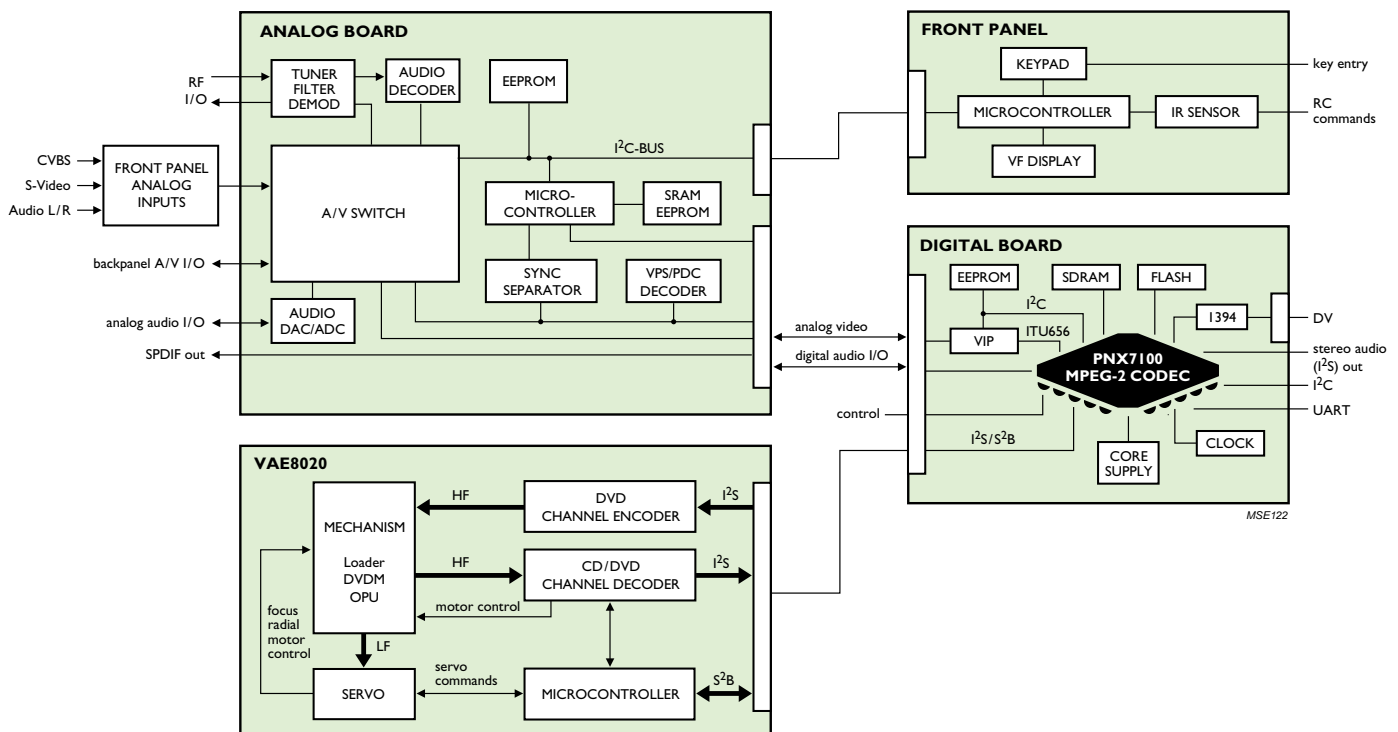

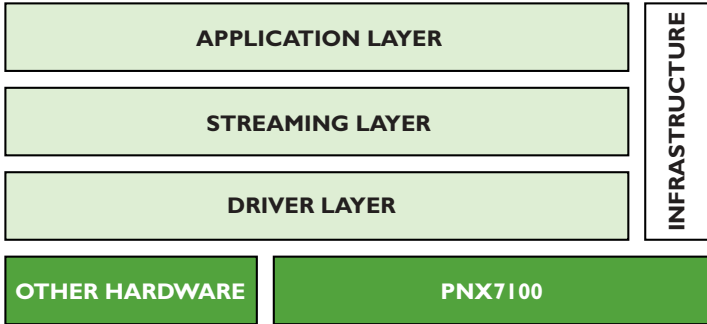

The PNX7100's layered software architecture comprises application, streaming, driver, and infrastructure layers.

Complete software stack

Developed in cooperation with leading members of the DVD+RW Alliance, the Reference Design's DVD+RW recorder software stack is fully compliant with industry standards. Its layered, modular architecture and C-language implementation allow for easy customization and future scalability.

Customizable reference design kit

The complete Reference Design includes hardware schematics, the complete software stack, and comprehensive documentation. The user interface, remote control interface, and front panel can be tailored to customer-specific requirements.

Technical specifications

REFERENCE DESIGN

| | |
|----------------------|--|
| Contents | Digital, analog, and front-panel board schematics; DVD+RW engine; software stack; documentation |
| Disc formats | <i>write (record)</i> DVD+RW/+R <i>read (playback)</i> DVD+RW/+R, DVD-V, DVD-R, CD, CD-R, CD-RW, CD-DA, VCD, SVCD |
| Speeds | <i>write (record)</i> up to 1.2x DVD+RW/+R |
| Disc size | 8 cm, 12 cm |
| Audio formats | <i>write (record)</i> stereo AC-3, stereo MPEG-1 L2 <i>read (playback)</i> LPCM, stereo AC-3, stereo MPEG, MP3 <i>bypass</i> audio bitstream on SPDIF |
| Video formats | <i>write (record)</i> MPEG-2 MP@ML <i>read (playback)</i> MPEG-2 MP@ML, MPEG-1, DV |

INPUT/OUTPUT

| | |
|----------------------|---|
| North America | <i>video in</i> Y/C, 1x CVBS, DV <i>video out</i> YUV, Y/C, CVBS <i>audio</i> stereo analog audio in/out, SPDIF out |
| Europe | <i>video in</i> Y/C, CVBS, DV <i>video out</i> CVBS, Y/C, RGB <i>audio</i> stereo analog I/O, SPDIF out |

FUNCTIONS

| | |
|----------------------|--|
| Playback | Normal play, pause, resume Fast forward/reverse Step forward/back Slow Direct title/track access Next/previous title/track/chapter Repeat title/chapter/all or track/all, A-B repeat Intro scan Time search Auto resume |
| Record | 1, 2, 3, 4 & 6 hour record modes North America/European record controls 6 timers VideoPlus+™ support (Europe), VCRPlus™ support (North America) Auto-search and manual channel installation One touch recording Record append |
| Video editing | Erase title Highlight favorite scene and full title play Automatic and manual chapter marker insertion Manual chapter marker deletion Disc write protection Edit title/disc name |
| Disc menu | 3 key frames, vertically oriented Alternate color, icons, background Alternate fonts, text, languages Customizable icons for channel, time |

DVD+RW Recorder Reference Design

Turnkey solution for DVD+RW/+R video recorders



www.semiconductors.philips.com

Technical specifications

FUNCTIONS (CONTINUED)

User interface Direct UI with local front-panel and TV (OSD)
Customizable top-level UI
Various looks (bitmaps, strings) and widgets (buttons, scroll bars)
Alternate menus (languages, text, bitmaps)
Customizable colors, backgrounds, icons
Adaptable local display, subset of icons and buttons
Adaptable remote control, OEM codes
Left-to-right languages and ideograms
TV aspect ratio selection (16/9, 4/3 letterbox, pan scan)
Clock calendar
Time display

Display planes 6 planes total with 2 independent paths: background, 2 video, sub-picture, on-screen graphics, cursor

Video I/O
digital CCIR656 input and output; progressive SMPTE293M output
analog CVBS, Y/C output (with Macrovision copy protection), YUV/RGB

Audio I/O
input 2 I²S, 2 SPDIF
output 6 I²S, 1 SPDIF

Scan modes Interlaced, progressive (480p)

Data interfaces IDE, IEEE1394, POS basic engine I/F (to VAE8020)

Drive interfaces Industry standard I²S and ATAPI

PNX7100 CODEC

Power supply 1.8 V and 3.3 V

Package 388-pin BGA

CPU core 32-bit MIPS PR3940 RISC

Video functions
decoding MPEG-2 MP@ML, DV, MPEG-1
transcoding DV to MPEG-2, MPEG to MPEG
encoding MPEG-2 MP@ML

Audio functions
decoding Dolby Digital[®] (AC-3), MPEG-2, MPEG-1 L2 (SVCD), LPCM (up to 96 KHz), DV-Audio (locked and unlocked modes)
encoding MPEG-1 L2 stereo or AC-3 stereo
bypass audio bitstream on SPDIF

Audio processing Dolby Pro Logic, stereo downmixing

Memory interface 133 MHz, supports fast SDRAM and synchronous Flash, patented memory arbitration; four scatter-gather DMAs between the data interfaces and SDRAM

Peripheral I/F EJTAG, PCI/XIO bus, 4 UARTs, 2 I²C ports, 32 GPIO pins

Use of these products in any manner that complies with the MPEG-2 standard is expressly prohibited without a license under applicable patents in the MPEG-2 patent portfolio, which license is available from MPEG LA, L.L.C., 250 Steele Street, Suite 300, Denver, Colorado 80206.

Dolby, Dolby Digital, and Dolby Pro Logic are registered trademarks of Dolby Laboratories. Other brands and product names are trademarks or registered trademarks of their respective owners.

Philips Semiconductors

Philips Semiconductors is a worldwide company with over 100 sales offices in more than 50 countries. For a complete up-to-date list of our sales offices please e-mail sales.addresses@www.semiconductors.philips.com. A complete list will be sent to you automatically. You can also visit our website <http://www.semiconductors.philips.com/sales>.

© Koninklijke Philips Electronics N.V. 2003

SCL 76

All rights reserved. Reproduction in whole or in part is prohibited without the prior written consent of the copyright owner. The information presented in this document does not form part of any quotation or contract, is believed to be accurate and reliable and may be changed without notice. No liability will be accepted by the publisher for any consequence of its use. Publication thereof does not convey nor imply any license under patent- or other industrial or intellectual property rights.



Date of release: January 2003
document order number: 9397-750-10646

Published in The Netherlands