

P87C66xX2

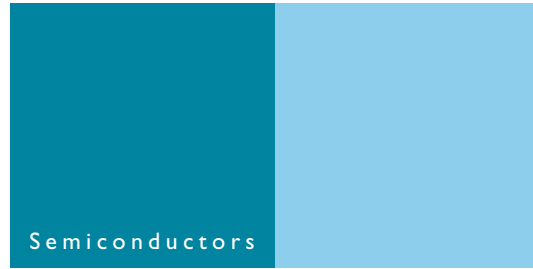

8-bit 80C51 16 KB OTP/ROM with 512 B RAM,
low voltage, low power, PCA and 400 KHz I²C



Features

- 80C51 Central Processing Unit
 - 16 KBytes OTP (P87C660X2, P87C661X2)
 - 16 KBytes ROM (P83C660X2, P83C661X2)
 - 512 bytes RAM
 - Low voltage (2.7V to 5.5V at 16 MHz) operation
- 12-clock operation with selectable 6-clock operation (via software, ISP, or parallel programmer)
- One 400 KHz byte oriented I²C interface in the P87C660X2 and two in the P87C661X2
- Programmable Counter Array (PCA)
 - PWM mode
 - Capture/Compare mode
- Memory addressing capability
 - Up to 64 Kbytes ROM and 64 Kbytes RAM
- Power control modes:
 - Clock can be stopped and resumed
 - Idle mode
 - Power-down mode
- Two speed ranges at V_{CC} = 5 V
 - 0 to 30 MHz in 6-clock operation mode
 - 0 to 33 MHz in 12-clock operation mode
- Dual Data Pointers
- Three security bits
- Four 8-bit I/O ports
- Watchdog timer

Benefits

- 400 KHz I²C supports multi-master communication at speeds up to 400 kb/s for easy interface with I²C peripherals
- 6-clock modes provides twice the performance of the conventional 80C51
- Fully static design allows a wide operating frequency range down to zero
- Allows private bus for Peripheral Management Controller

Description

The devices are Single-Chip 8-bit Microcontrollers manufactured in an advanced CMOS process and are derivatives in the 80C51 microcontroller family. The instruction set is 100% compatible with the 80C51 instruction set.

The P87C660X2 has a single 400 KHz I²C serial port and the P87C661X2 has a second 400 KHz I²C serial port. The second 400 KHz I²C serial port has dedicated open drain outputs.

These devices support 6-clock/12-clock mode by programming an OTP bit (OX2) using parallel programming. In addition, an SFR bit (X2) in the clock control register (CKCON) also selects between 6-clock/12-clock mode.

Applications

The added features of the P87C66xX2 make it a powerful microcontroller for applications that require pulse width modulation, high-speed I/O, I²C communication and up/down counting capabilities such as motor control.

The P87C66xX2 is suitable for a wide variety of applications that benefit from low EMI and the ability to easily add more peripherals like EEPROM, display drivers, A/D converters hardware monitors etc. via the I²C bus. It is also extremely well suited for Intelligent Platform Management (IPMI) applications in servers and high-end PCs where I²C serves as a physical protocol for the interface.

- Industrial Control
- Consumer Applications
- Peripheral Management Controller

P8x660X2 ordering information

Part Number	Temperature Range	Package	Drawing Number
P83C660X2FA	-40° C to +85° C	PLCC; 44 leads	SOT-187-2
P83C660X2BBD	0° to +70° C	LQFP; 44 leads	SOT-389-1
P87C660X2FA	-40° C to +85° C	PLCC; 44 leads	SOT-187-2
P87C660X2BBD	0° to +70° C	LQFP; 44 leads	SOT-389-1

P8x661X2 ordering information

Part Number	Temperature Range	Package	Drawing Number
P83C661X2FA	-40° C to +85° C	PLCC; 44 leads	SOT-187-2
P83C661X2BBD	0° to +70° C	LQFP; 44 leads	SOT-389-1
P87C661X2FA	-40° C to +85° C	PLCC; 44 leads	SOT-187-2
P87C661X2BBD	0° to +70° C	LQFP; 44 leads	SOT-389-1

PHILIPS

P87C66xX2

8-bit 80C51 16 KB OTP/ROM with 512 B RAM, low voltage, low power, PCA and 400 KHz I²C



P87C66xX2 block diagram

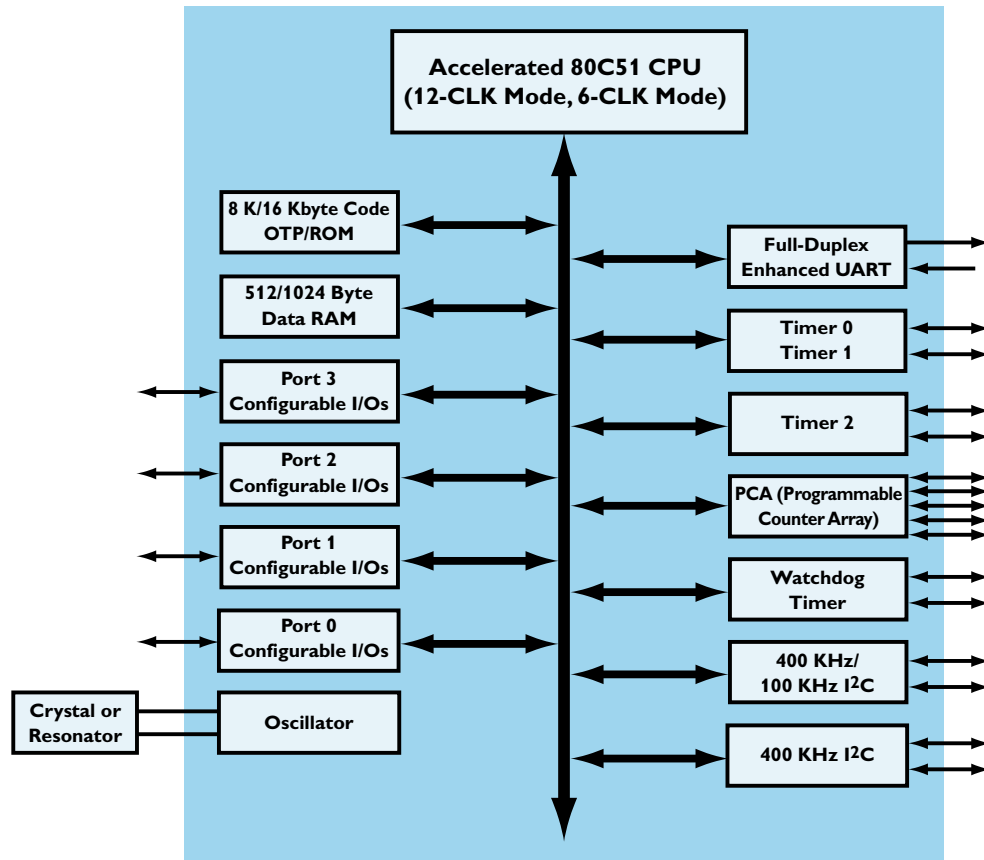

Purchase of Philips I²C components conveys a license under the Philips' patent to use the components in the I²C system provided the system conforms to the I²C specification defined by Philips.

www.semiconductors.philips.com/microcontrollers



Philips Semiconductors

Philips Semiconductors is a worldwide company with over 100 sales offices in more than 50 countries. For a complete up-to-date list of our sales offices please e-mail sales.addresses@www.semiconductors.philips.com.

A complete list will be sent to you automatically. You can also visit our website <http://www.semiconductors.philips.com/sales>

© Koninklijke Philips Electronics N.V. 2003

All rights reserved. Reproduction in whole or in part is prohibited without the prior written consent of the copyright owner. The information presented in this document does not form part of any quotation or contract, is believed to be accurate and reliable and may be changed without notice. No liability will be accepted by the publisher for any consequence of its use. Publication thereof does not convey nor imply any license under patent- or other industrial or intellectual property rights.

Date of release: April 2003
document order number: 9397 750 11341

Published in U.S.A.