

PCI-7134DVBT(H) Reference Design Kit

The Philips PCI-7134DVBT(H) Reference Design Kit is a complete solution for adding hybrid broadcast reception to PCs and PCI-based products in DVB-T digital TV markets. Its proven SAA7134-based design and low-profile PCI footprint reduce time-to-market and ensure future-proof transition from analog to digital broadcasting.

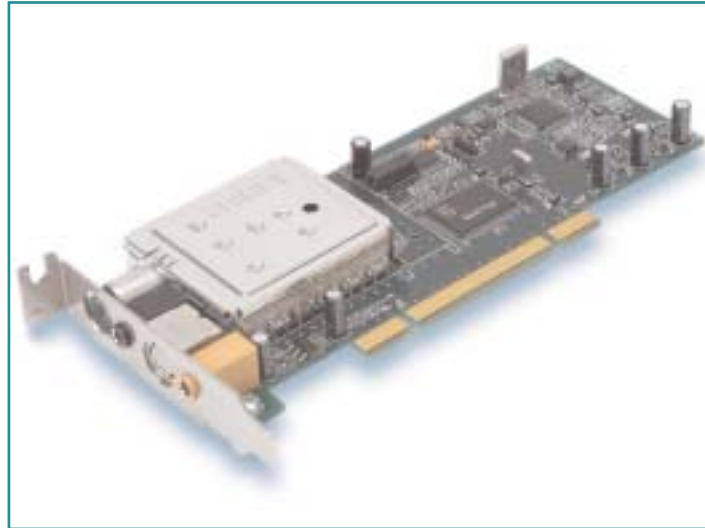

Key features

- Analog TV reception (terrestrial and cable): B/G, D/K, I, and L/L' standards
- Digital TV capture (DVB-T) for 2K/8K COFDM
- Space efficient, low-profile PCI v2.2 MD2 footprint
- Can leverage PC software-based MPEG demux and en/decoding to support a variety of popular TV functions such as time shifting
- Complete device driver kit (DDK) includes SAA7134 drivers

Based on SAA7134 PCI video and stereo decoder

- Fully automatic detect and decode of all analog TV video standards (PAL, NTSC, SECAM)
- Transport stream capture and DMA transfer
- Integrated digital Nicam and dual FM stereo decoding
- Adaptive multi-standard 2/4-line comb filter
- VBI data capture for Closed Captioning, Teletext, and Intercast
- Full three-level hardware Macrovision detection

Other board components

- TD1316 (VHF/UHF) hybrid TV tuner
- TDA10046 channel decoder
- IF downconverters
- Flexible inputs: RF tuner, remote control, S-Video, audio

SAA7134 low-profile PCI reference card and software for hybrid TV receivers (DVB-T and PAL/NTSC/SECAM)



The PCI-7134DVBT(H) reference design kit is a complete hardware and software solution for adding hybrid TV receiver functionality to PCs and PCI-based set-top boxes. One in a series of SAA7134-based reference designs, the PCI-7134DVBT(H) supports all video standards used in analog cable/terrestrial and digital terrestrial (DVB-T) markets, enabling low-cost future-proof transition from analog to digital broadcasting. This second-generation solution offers all the features of the world's first hybrid DVB-T reference design in a smaller, low-profile PCI form factor.

The PCI-7134DVBT(H) leverages the highly integrated Philips SAA7134 video decoder to significantly reduce the BOM in hybrid TV applications. On a single chip, the SAA7134 handles analog TV video and stereo decoding, Macrovision copy protection detection, and MPEG-2 transport stream capture and supplies a PCI bus mastering interface for high-speed I/O to other key components.

Software-based MPEG decoding and demultiplexing dramatically reduces the cost of digital broadcast reception in PCs and other PCI-based devices. Ideal for analog and digital TV reception, the PCI-7134DVBT(H) is also an cost-effective foundation for implementing sophisticated TV-centric features such as data broadcasting, time-shift recording, video editing, broadband Internet reception, and emerging MHP applications.

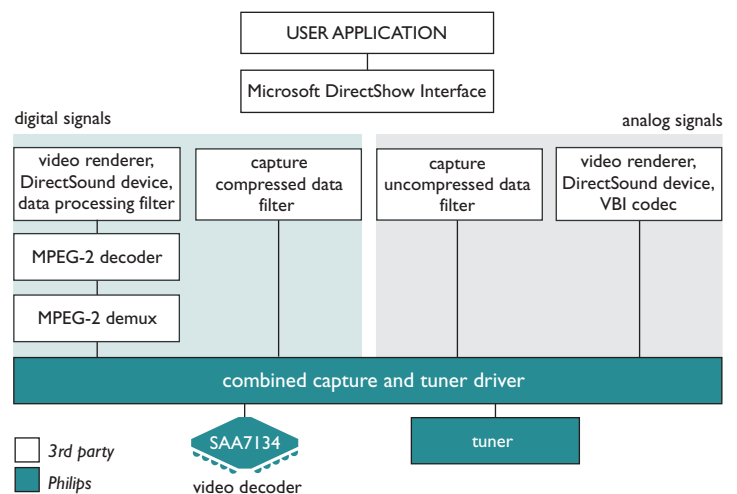

PHILIPS

PCI-7134DVBT(H) Reference Design Kit

SAA7134 low-profile PCI reference card and software for hybrid TV receivers (DVB-T and PAL/NTSC/SECAM)



SAA7134 analog/DVB-T reference card

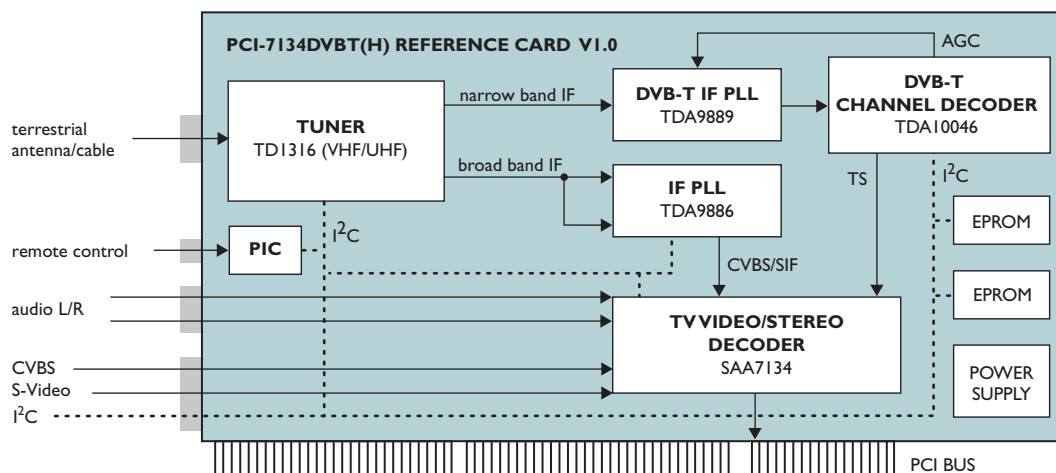

A complete package including full software support

The PCI-7134DVBT(H) lets manufacturers of PCI TV cards quickly demonstrate SAA7134 capabilities and deliver a wide range of products to meet the growing demand for PCI-based video applications. It includes a low-profile PCI card, an installation and user guide, board-design, schematic, and Gerber files, and selected video cables.

The PCI-7134DVBT(H) also includes a Device Driver Kit (DDK) comprising:

- a combined capture and tuner driver supporting SAA713x decoders and a tuner for all common analog and digital TV standards. The driver follows the Windows Driver Model's AV streaming approach and supports the Broadcast Driver Architecture (BDA) in pure analog, digital, or hybrid TV applications. It is WHQL certified and supported for Windows 98/ME/2000/XP.
- a DirectShow-based application demonstrating hybrid (PAL, DVB-T) TV reception on the reference board

- documentation, installation and operating instructions for the driver and demo application
- a tuner driver development kit including sample code for the TD1316 tuner and guidelines for supporting third-party tuners

Use of this product in any manner that complies with the MPEG-2 Standard is expressly prohibited without a license under applicable patents in the MPEG-2 patent portfolio, which license is available from MPEG LA, L.L.C., 250 Steele Street, Suite 300, Denver, CO 80206.

Philips Semiconductors

Philips Semiconductors is a worldwide company with over 100 sales offices in more than 50 countries. For a complete up-to-date list of our sales offices please e-mail sales.addresses@www.semiconductors.philips.com. A complete list will be sent to you automatically. You can also visit our website <http://www.semiconductors.philips.com/sales>.

© Koninklijke Philips Electronics N.V. 2003

SCL 76

All rights reserved. Reproduction in whole or in part is prohibited without the prior written consent of the copyright owner. The information presented in this document does not form part of any quotation or contract, is believed to be accurate and reliable and may be changed without notice. No liability will be accepted by the publisher for any consequence of its use. Publication thereof does not convey or imply any license under patent- or other industrial or intellectual property rights.



Date of release: July 2003

document order number: 9397-750-11608

Published in USA