

PCI-7133ATSC(H) Reference Design Kit

The Philips PCI-7133ATSC(H) Reference Design Kit is a complete solution for adding analog/digital broadcast TV reception to PCs and PCI-based products in ATSC digital TV markets. Its proven half-size PCI card design reduces cost and time-to-market and ensures future-proof transition from analog to digital broadcasting.



Key features

- Analog TV reception (terrestrial and cable): System M/N standards
- Digital TV capture (ATSC) for 8-VSB
- Half-size PCI v2.2 footprint
- Can leverage PC software-based MPEG demux and en/decoding to support a variety of popular TV functions such as time shifting
- Complete device driver kit (DDK) includes SAA7133 drivers

Based on SAA7133 PCI video and stereo decoder

- Fully automatic detection and decoding of worldwide analog TV video formats (PAL, NTSC, SECAM)
- Captures transport streams from digital TV broadcasts and MPEG datastreams in time-shift applications
- Certified three-level Macrovision detection circuitry
- Automatic standard detection and decoding of TV stereo formats: BTSC (with dbx noise reduction), SAP, EIAJ, and FM Radio
- Captures raw VBI data (for Closed Captioning, Teletext, NABST, etc.)
- Adaptive multi-standard 2/4 line comb filter

Other board components

- Philips TUV1236D Digital & Analog Terrestrial Receiver (NIM) module
- I²C EEPROM

SAA7133 PCI reference card and software for analog/digital TV receivers (ATSC and NTSC)



The PCI-7133ATSC(H) reference design kit is a complete hardware and software solution for adding analog/digital TV receiver functionality to PCs and PCI-based set-top boxes. One in a series of SAA7133-based reference designs, PCI-7133ATSC(H) supports all video standards used in analog cable/terrestrial and digital terrestrial (ATSC) markets, enabling low-cost transition from analog to analog/digital broadcasting. This solution offers all the features of the cost effective analog/digital ATSC reference design in a half-size PCI form factor.

PCI-7133ATSC(H) leverages the highly integrated Philips SAA7133 video decoder to significantly reduce the BOM in analog/digital TV applications. On a single chip, the SAA7133 handles fully automatic detection and decoding of all worldwide analog TV video standards, TV stereo decoding for North America and Japan, Macrovision copy protection detection, and MPEG-2 transport stream capture. It supplies a PCI bus mastering interface for high-speed I/O to other key components.

Software-based MPEG decoding and demultiplexing dramatically reduces the cost of digital broadcast reception in PCs and other PCI-based devices. Ideal for analog and digital TV reception, PCI-7133ATSC(H) is also a cost-effective foundation for implementing sophisticated TV-centric features such as data broadcasting, time-shift recording, video editing, broadband Internet reception, and emerging MCE XP applications.

SAA7133 NTSC/ATSC reference card

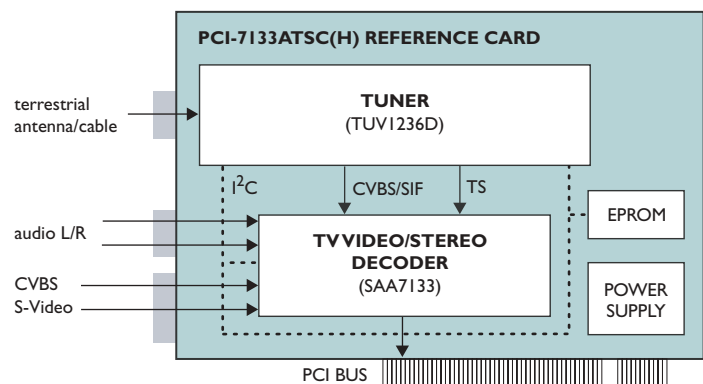

PHILIPS

PCI-7133ATSC(H) Reference Design Kit

SAA7133 PCI reference card and software for analog/digital TV receivers (ATSC and NTSC)



A complete package including full software support

PCI-7133ATSC(H) lets manufacturers of PCI TV cards quickly demonstrate SAA7133 capabilities and deliver a wide range of products to meet the growing demand for PCI-based video applications. It includes a half-size PCI reference card, an installation and user guide, board, schematic, and Gerber files, and video cables.

PCI-7133ATSC(H) also includes a Device Driver Kit (DDK) comprising:

- A combined capture and tuner driver supporting SAA713x decoders and a tuner for all common analog and digital TV standards. The driver follows the Windows Driver Model's AV streaming approach and supports the Broadcast Driver Architecture (BDA) in pure analog, digital, or analog/digital TV applications. It is WHQL certified and supported for Windows 98/ME/2000/XP.
- A DirectShow-based application demonstrating analog/digital (NTSC, ATSC) TV reception on the reference board
- Documentation, installation, and operating instructions for the driver and demo application
- A tuner driver development kit including sample code for the TUV1236D tuner and guidelines for supporting third-party tuners.

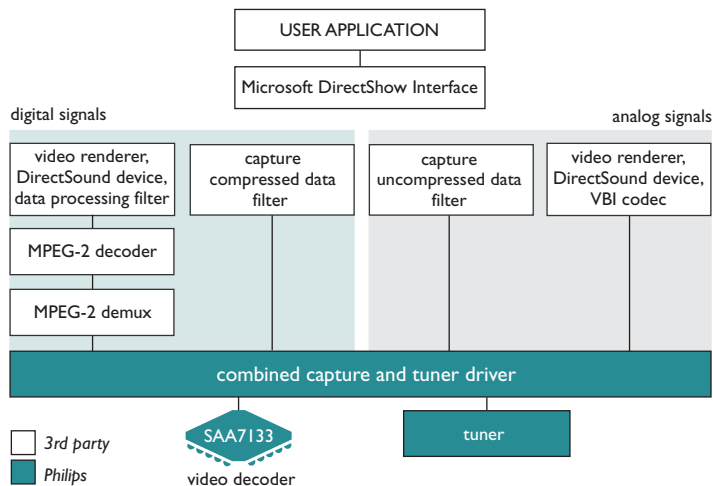

Typical application trajectory in analog/digital TV reception applications

Use of this product in any manner that complies with the MPEG-2 Standard is expressly prohibited without a license under applicable patents in the MPEG-2 patent portfolio, which license is available from MPEG LA, L.L.C., 250 Steele Street, Suite 300, Denver, CO 80206.

Philips Semiconductors

Philips Semiconductors is a worldwide company with over 100 sales offices in more than 50 countries. For a complete up-to-date list of our sales offices please e-mail sales.addresses@www.semiconductors.philips.com. A complete list will be sent to you automatically. You can also visit our website <http://www.semiconductors.philips.com/sales>.

© Koninklijke Philips Electronics N.V. 2004

SCL 76

All rights reserved. Reproduction in whole or in part is prohibited without the prior written consent of the copyright owner. The information presented in this document does not form part of any quotation or contract, is believed to be accurate and reliable and may be changed without notice. No liability will be accepted by the publisher for any consequence of its use. Publication thereof does not convey or imply any license under patent- or other industrial or intellectual property rights.



Date of release: January 2004
document order number: 939775012565

Published in USA