

ISP110x

USB physical layer transceiver for SoC applications

With voltages down to 1.65 V, an integrated voltage regulator, and small chip-scale packaging, the ISP110x is ideal for SoC applications. Options include single-ended, differential, or selectable.

Key features

- USB Specification Rev. 2.0
- Variable I/O voltage levels: 1.65 V to 3.6 V
- Available in very small footprint packages (see overleaf for details)
- Low-power operation
- Software-controlled USB connection (SoftConnect™)
- Slew-rate-controlled differential data driver
- Integrated 5V-to-3.3V voltage regulator
- Two single-ended receivers with hysteresis
- Compatible with Serial Interface Engine Specification from USB Implementers' Forum
- Full industrial operating temp range: -40° C to +85° C

Description

The ISP110x series of USB transceivers operate at supply voltages between 1.65 V and 3.6 V. This makes them ideally suited to mobile and portable applications, which often require operation at 1.8 V.

Based on the best-selling PDIUSBPI1A full-speed transceiver, the ISP110x series has an added level shifter and a power regulator.

All the I/O pads are designed to ensure that the static current meets design specifications.

To make the ISP110x termination compatible to USB Specification Rev. 2.0, the CMOS driver is designed to make its output impedance more process-stable. This reduces the unmatched termination, and therefore reduces potential rings and undershoots.

The ISP110x uses two independent power supplies— $V_{CC(I/O)}$ and V_{CC} (or V_{reg})—for the analog part and the digital part, respectively. The power supply for the I/O interface is provided independently, by another source. This further reduces the power supply ground bouncing for sensitive analog (D+, D-) pads.

Product Numbers

- ISP1102: Bidirectional differential. VBUSDET but not in suspend mode. Works very well with 3.3V supply voltage
- ISP1104: Single-ended or differential (selectable) with VBUSDET for switching from USB to other serial protocols
- ISP1105: Single-ended or differential (selectable)
- ISP1106: Differential

PHILIPS

ISP110x Product Selection Guide

Product Description	Signal Name/Package Name [1] [2]	ISP1102	ISP1104	ISP1105	ISP1106
Single-ended receiver output	VP, VM	X	√	√	X
Differential data receiver output	RCV	√	√	√	√
Driver data input	VPO/VO, VMO/FSE0	VP/VPO and VM/VMO are bidirectional I/Os	VPO/VO, VMO/FSE0	VPO/VO, VMO/FSE0	VPO, VMO
Transmitter enable	$\overline{\text{OE}}$	√	√	√	√
Mode select	MODE	Internally tied to HIGH	√	√	Internally tied to HIGH
Suspend control	SUSPND	√	√	√	√
Full-speed/Low-speed select	SPEED	Full-speed only	Full-speed only	√	√
SoftConnect™ control	SOFTCON	√	√	√	√
VBUS detect	VBUSDET	√ [3]	√	X	X
Package	TSSOP HBCC HVQFN	X 16-pin 14-pin	X 16-pin X	X 16-pin X	16-pin 16-pin X

[1] √ — Denotes that the signal or the package is available for the product. [2] X — Denotes that the signal or the package is not available for the product. [3]

VBUSDET does not function in 'suspend' mode

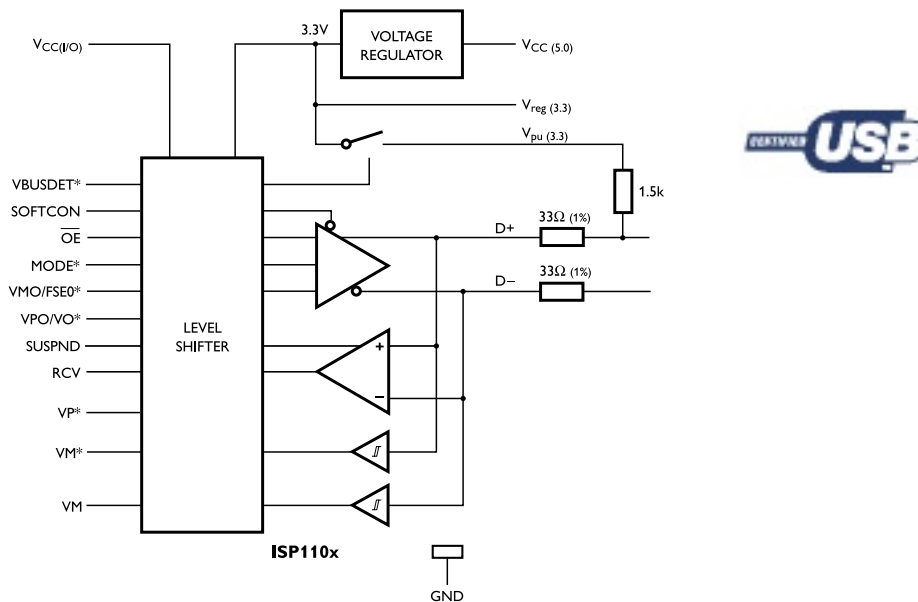

ISP110x Block Diagram

Philips Semiconductors

Philips Semiconductors is one of the world's top semiconductor suppliers, with 20 manufacturing and assembly sites and a sales organization that delivers in 60 countries.

For a complete up-to-date list of our sales offices please visit our website <http://www.semiconductors.philips.com/sales>

©2005 Koninklijke Philips Electronics N.V.

All rights reserved. Reproduction in whole or in part is prohibited without the prior written consent of the copyright owner.

The information presented in this document does not form part of any quotation or contract, is believed to be accurate and reliable and may be changed without notice. No liability will be accepted by the publisher for any consequence of its use. Publication thereof does not convey nor imply any license under patent- or other industrial or intellectual property rights.

date of release: september 2005

document order number: 9397 750 13953

Printed in the Netherlands

