



NXP Aero[®] quad-band GSM/GPRS/EDGE radio front-ends AERO42xx*

Industry's smallest, highest-performing transceivers for multi-band GSM/GPRS/EDGE handsets and modems

These highly integrated, market-proven transceivers use a standard CMOS RF process to provide excellent GSM/GPRS/EDGE performance, and require as little as 1.0 cm² to implement an entire quad-band radio.

Key features

- ▶ 100% CMOS RF technology
- ▶ Digital low-IF receiver
 - GSM 850 Class 4, small MS
 - E-GSM 900 Class 4, small MS
 - DCS 1800 Class 1
 - PCS 1900 Class 1
 - GPRS and E-GPRS Class 12 capable
- ▶ Dual transmitter architecture
 - Offset PLL for GMSK modulation transmission
 - Linear transmit chain for 8-PSK modulation transmission
 - One-step transmitter calibration for EDGE
 - Single-ended transmit outputs
- ▶ Universal baseband interface
- ▶ Highest integration for lowest BOM, best performance, and smallest size
 - Integrated frequency synthesizer
 - Integrated digitally-controlled crystal oscillator (DCXO)
- ▶ Three-wire serial interface
- ▶ Operation: 2.7 to 3.0 V

Applications

- ▶ Multi-band GSM/GPRS/EDGE digital cellular handsets and smartphones
- ▶ Multi-band GSM/GPRS/EDGE wireless data modems

Each member of the NXP AERO42xx series uses a patented, market-proven cellular technology – based on a digital low-IF receiver and an innovative, dual-transmitter architecture – to deliver excellent GSM/GPRS/EDGE performance.

Lowest BOM and smallest footprint

Compared to competing solutions, these transceivers reduce component count and board space by 50%, and implement an entire quad-band radio, excluding the power amplifier and antenna switch, in a footprint as small as 1.0 cm².

Easy to design and manufacture

Delivering industry-leading performance, they improve call quality and ease the design and manufacturing processes.

* Formerly available as the Si42xx series from Silicon Labs

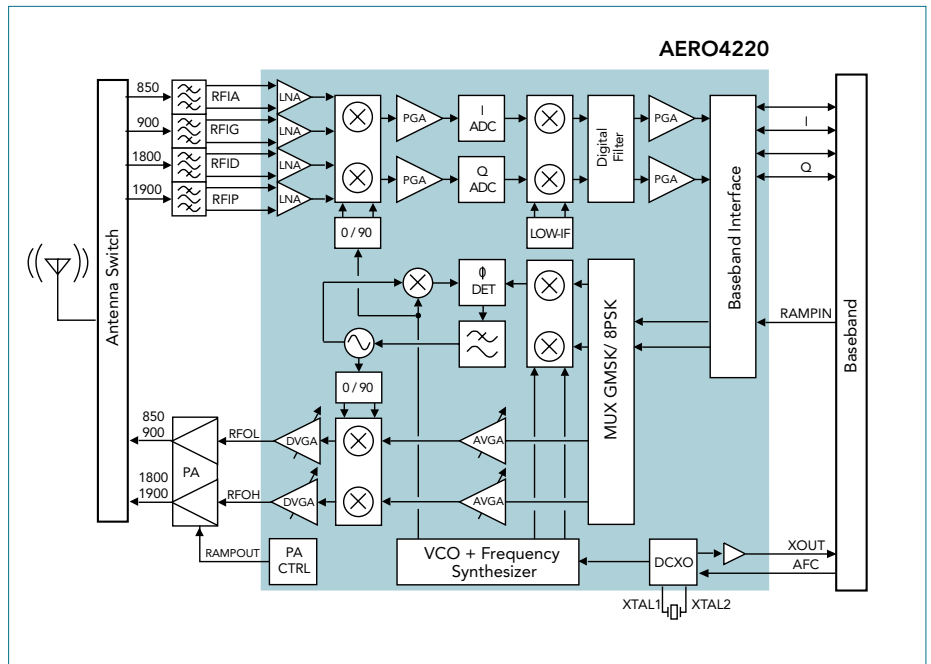

AERO4220 block diagram

Highest level of integration

Each integrates all the sensitive components, including Tx and RF VCOs, loop filters, tuning inductors, varactors, clock-coupling capacitors, and a complete DXCO, into the smallest formats in the industry. The AERO4213 goes a step further, integrating an analog baseband and a DigRF baseband interface.

The very high level of integration simplifies design and ensures consistent performance for customers seeking turnkey RF designs while improving handset yields.

Proven technology

The receiver leverages a proven digital low-IF architecture that avoids the inherent difficulties associated with direct-conversion receivers while delivering higher performance, lower overall cost, and reduced complexity. The transmit section uses an offset phase-locked loop (OPLL) integrated with a patented synthesizer technology. The unique dual-transmitter architecture enables one-step transmitter calibration for EDGE, so high-volume manufacturing and production is significantly more streamlined.

To make design-in even simpler, the software-programmable universal baseband allows handset designers to implement the transceiver with all leading basebands.

		AERO4209	AERO4210	AERO4213	AERO4220
		Aero II ULCH	Aero II	Aero IIed	Aero IIe
Application					
Standard		GSM/GPRS	GSM/GPRS	GSM/GPRS/EDGE	GSM/GPRS/EDGE
Package		5 x 5 mm	5 x 5 mm	6 x 7 mm	5 x 6 mm
		25-pin QFN	32-pin QFN	44-pin LGA	36-pin LGA
Footprint (cm ²)		0.8	1	1.9	1.4
Component count					
Dual-band		12	12	16	13
Triple-band		-	16	20	17
Quad-band		-	20	24	21
Receiver					
Architecture		Digital low-IF	Digital low-IF	Digital low-IF	Digital low-IF
Noise figure (dB)	GSM 850	2.9	2.1	2.1	2.1
	E-GSM 900	3.1	2.3	2.3	2.3
	DCS 1800	2.8	2.4	2.4	2.4
	PCS 1900	2.9	2.5	2.5	2.5
3-MHz blocker (dBm)	GSM	-21	-21	-21	-21
	DCS/PCS	-25	-25	-25	-25
Transmitter: GMSK					
Architecture		GMSK-OPLL	GMSK-OPLL	GMSK-OPLL	GMSK-OPLL
Phase error (deg)	RMS	1.9	1.9	1.9	1.9
	PEAK	5	5	5	5
RFOI spectrum	400 kHz	-66	-66	-66	-66
RFOH spectrum	400 kHz	-65	-65	-65	-65
RFOI phase noise (dBc/Hz)	10 MHz	-160	-160	-160	-160
	20 MHz	-165	-165	-165	-165
RFOH phase noise (dBc/Hz)	20 MHz	-160	-160	-159	-159
Transmitter: 8-PSK					
Architecture		-	-	8-PSK direct linear	8-PSK direct linear
OOS (dBc)		-	-	-40	-40
EVM (%)	RMS	-	-	3	3
	PEAK	-	-	10	10
RFOI spectrum	400 kHz	-	-	-64	-64
RFOH spectrum	400 kHz	-	-	-64	-64
RFOI phase noise (dBc/Hz)	10 MHz	-	-	-154	-154
RFOH phase noise (dBc/Hz)	20 MHz	-	-	-163	-163
	20 MHz	-	-	-155	-155
Reference oscillator					
Format		XTAL	XTAL	XTAL	XTAL

www.nxp.com

founded by

PHILIPS

© 2007 NXP B.V.

All rights reserved. Reproduction in whole or in part is prohibited without the prior written consent of the copyright owner. The information presented in this document does not form part of any quotation or contract, is believed to be accurate and reliable and may be changed without notice. No liability will be accepted by the publisher for any consequence of its use. Publication thereof does not convey nor imply any license under patent- or other industrial or intellectual property rights.

Date of release: April 2007

Document order number: 9397 750 15986

Printed in the Netherlands