



NXP Bluetooth® 2.0 + EDR solution BGB210S

Miniature, low-power Bluetooth 2.0 + EDR

This complete solution, designed for a range of mobile applications, provides faster data transfer and offers the industry's lowest power consumption in the smallest footprint. It also supports coexistence with 802.11 WLAN.

Key features

- ▶ Complete, fully tested Bluetooth Class 2-compliant solution
 - Supports Bluetooth 2.0 + EDR
 - Minimum number of external components required
 - Low total cost of ownership
- ▶ Ultra-small TFBGA44 package (3.0 x 5.0 x 1.15 mm)
- ▶ Operating temperature range of -40 to 85 °C
- ▶ Highly integrated, all-CMOS solution
 - Only external RF filter and a few non-RF-critical components required
 - ARM7 processor with on-chip RAM and ROM
 - System interfaces (UART, PCM, WLAN coexistence PTA)
 - Advanced N-ZIF RF transceiver architecture
 - Sensitivity -89 dBm (typical value, measured at IC)
 - Output power +2 dBm (typical value, measured at IC)
 - Single 1.8 V power supply
- ▶ Low power consumption
 - HV3 mode: 14 mA
 - Sniff 1.28s (master): 127 µA
 - System off 5 µA
- ▶ Small application PCB footprint (35 mm²)
- ▶ Supports large range of system clocks
- ▶ Built-in fractional clock divider supports CDMA, WCDMA, GSM, GPRS, etc.
- ▶ ROM code patch facility to support software updates
- ▶ Coexists with 802.11 WLAN

Applications

- ▶ Cell phones, smartphones, and other mobile devices
- ▶ Cordless phones

The NXP BGB210S is a fourth-generation solution for Bluetooth 2.0 + EDR (Enhanced Data Rate) wireless connectivity. It provides complete, plug-and-play Bluetooth 2.0 + EDR operation in a low-cost package that measures only 15 mm².

Optimized for hosted and embedded applications, the BGB210S reduces board space, lowers overall cost, and speeds time-to-market for mobile applications including cell phones, smartphones, cordless phones, and PDAs.

With its high level of system functionality, the BGB210S delivers quicker design cycles, lower risk, simplified manufacturing, and a reduced bill of materials. The small, single-package format also minimizes the total cost of ownership by simplifying assembly and test and reducing yield loss.

Bluetooth 2.0 + EDR

The Bluetooth 2.0 + EDR standard provides data rates up to three times higher than previous versions, resulting in faster data transfer and lower power consumption for a given data throughput. Higher bandwidth utilization is especially important in applications that mix voice and data, and in multipoint and scatternet scenarios.

Industry-leading small size

Advanced processing technologies and packaging techniques optimize cost, size, and performance. The entire system is housed in an ultra-small, 44-pin TFBGA package that measures only 3.0 x 5.0 x 1.15 mm. A few non-RF-critical components, an antenna filter, and an antenna are all that's required to complete the application.

The BGB210S integrates Bluetooth RF functionality and embedded Link Manager (LM) software with a host controller interface (HCI).

The baseband, which is manufactured in a state-of-the-art, low-power CMOS technology, uses an integrated industry-standard ARM7 microcontroller (with internal RAM and ROM) to provide ample processing power. The core supports a variety of interfaces, including UART, PCM, and wireless LAN (WLAN) coexistence using packet traffic arbitration (PTA).

The transceiver, manufactured in baseline CMOS technology, uses a near-zero IF (N-ZIF) radio architecture optimized for systems with multiple wireless links, so antenna placement is more flexible in GSM/WCDMA phones. The transceiver also has an integrated Rx/Tx switch, along with a balun, for a single-ended, 50-Ω connection to the antenna filter.

The reference clock can be provided by a crystal or the host system.

RF power control

The BGB210S is designed for mobile applications, so it supports Class 2 and Class 3 of the Bluetooth 2.0 + EDR standard. Also, to limit range and improve security, there is a mode with reduced output power for use during inquiry scan.

Low power consumption

For very low-power Bluetooth operation in mobile phones, the BGB210S uses a single 1.8 V supply. Power consumption in voice (HV3) mode is only 14 mA, in Sniff 1.28s mode is only 127µA, and during System Off mode is less than 5 µA.

Coexistence with 802.11 WLAN

The BGB210S supports collaboration with co-located IEEE 802.11 WLAN systems. A dedicated software and hardware interface implements PTA with voice priority between the BGB210S and the WLAN system. The PTA enables simultaneous Bluetooth voice connection and WLAN VoIP. There are special arrangements to support burst and fragmented frames, and the BGB210S implements adaptive frequency hopping (AFH) as defined in the Bluetooth 2.0 specification.

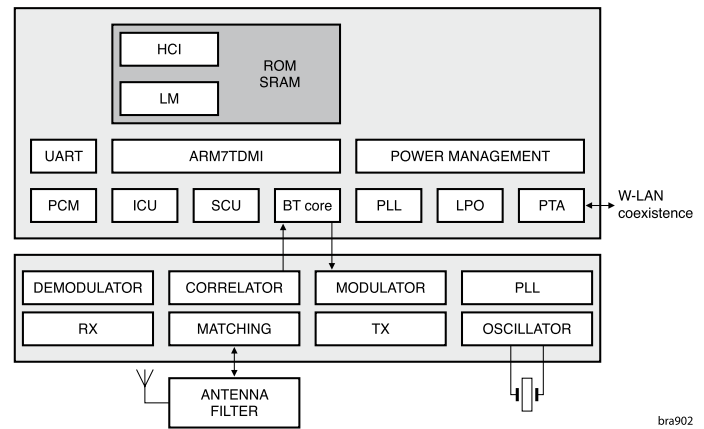

BGB210S functional block diagram

Part No.	Description	Process	Package	Size
BGB210S	Bluetooth 2.0 + EDR	CMOS	TFBGA44	3.0 x 5.0 x 1.15 mm

Ordering information

www.nxp.com



© 2007 NXP B.V.

All rights reserved. Reproduction in whole or in part is prohibited without the prior written consent of the copyright owner. The information presented in this document does not form part of any quotation or contract, is believed to be accurate and reliable and may be changed without notice. No liability will be accepted by the publisher for any consequence of its use. Publication thereof does not convey nor imply any license under patent- or other industrial or intellectual property rights.

Date of release: June 2007

Document order number: 9397 750 16087

Printed in the Netherlands