

TSSOP48: plastic thin shrink small outline package; 48 leads;
body width 4.4 mm; lead pitch 0.4 mm

SOT480-1

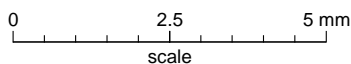
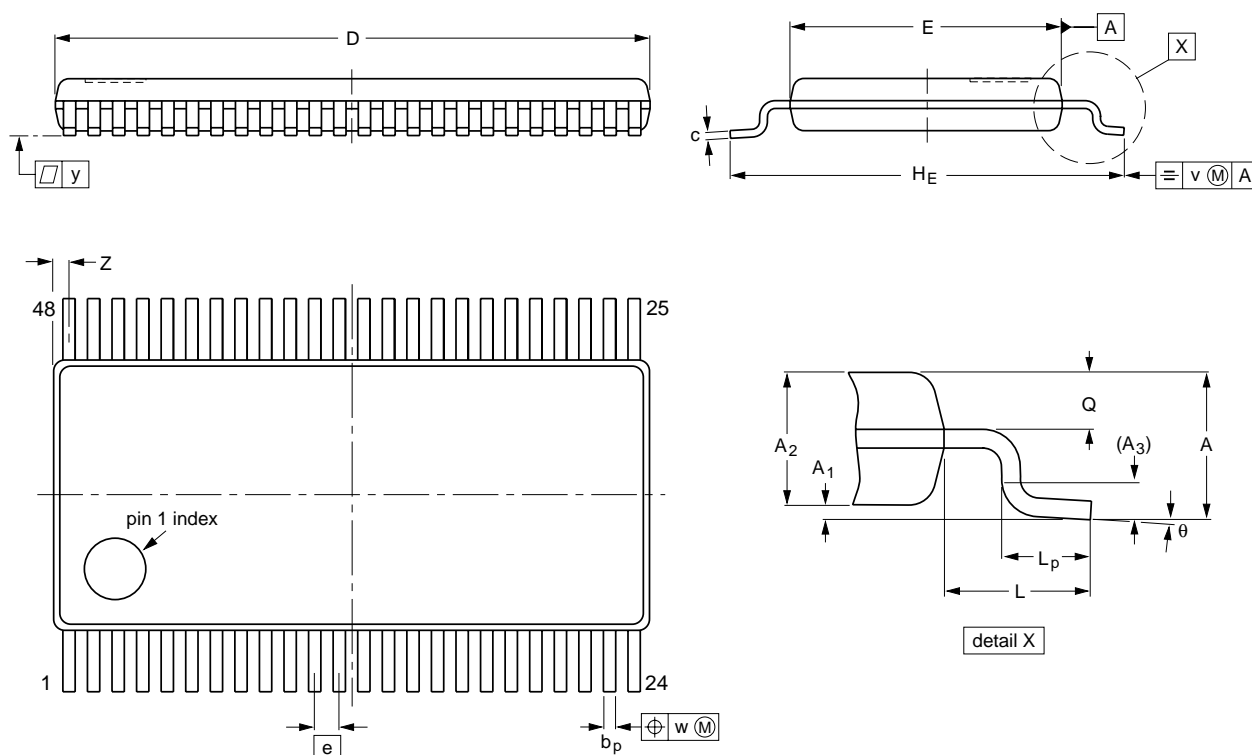

DIMENSIONS (mm are the original dimensions)

UNIT	A max.	A ₁	A ₂	A ₃	b _p	c	D ⁽¹⁾	E ⁽²⁾	e	H _E	L	L _p	Q	v	w	y	Z ⁽¹⁾	θ
mm	1.10	0.15 0.05	0.95 0.85	0.25	0.23 0.13	0.20 0.09	9.80 9.60	4.50 4.30	0.40	6.60 6.20	1.00	0.70 0.50	0.40 0.30	0.20	0.07	0.08	0.40 0.10	8° 0°

Notes

1. Plastic or metal protrusions of 0.15 mm maximum per side are not included.
2. Plastic interlead protrusions of 0.25 mm maximum per side are not included.

OUTLINE VERSION	REFERENCES			EUROPEAN PROJECTION	ISSUE DATE
	IEC	JEDEC	EIAJ		
SOT480-1		MO-153			97-03-20 99-12-27