

DAC1201D125

Dual 12-bit DAC, up to 125 Msps

Rev. 01 — 27 November 2008

Product data sheet

1. General description

The DAC1201D125 is a dual-port, high-speed, 2-channel CMOS Digital-to-Analog Converter (DAC), optimized for high dynamic performance with low power dissipation. Supporting an update rate of up to 125 Msps, the DAC1201D125 is suitable for Direct IF applications.

Separate write inputs allow data to be written to the two DAC ports independently of one another. Two separate clocks control the update rate of each DAC port.

The DAC1201D125 can interface two separate data ports or one single interleaved high-speed data port. In Interleaved mode, the input data stream is demultiplexed into its original I and Q data and latched. The I and Q data is then converted by the two DACs and updated at half the input data rate.

Each DAC port has a high-impedance differential current output, suitable for both single-ended and differential analog output configurations.

The DAC1201D125 is pin compatible with the AD9765, DAC2902 and DAC5662.

2. Features

- Dual 12-bit resolution
- 125 Msps update rate
- Single 3.3 V supply
- Dual-port or Interleaved data modes
- 1.8 V, 3.3 V and 5 V compatible digital inputs
- Internal and external reference
- 2 mA to 20 mA full-scale output current
- **Typical 185 mW power dissipation**
- 16 mW power-down
- SFDR: 81 dBc; $f_o = 1$ MHz; $f_s = 52$ Msps
- **SFDR: 78 dBc; $f_o = 10.4$ MHz; $f_s = 78$ Msps**
- SFDR: 74 dBc; $f_o = 1$ MHz; $f_s = 52$ Msps; -12 dBFS
- LQFP48 package
- Industrial temperature range of -40 °C to $+85$ °C

3. Applications

- Quadrature modulation
- Medical/test instrumentation
- Direct IF applications
- Direct digital frequency synthesis
- Arbitrary waveform generator

4. Ordering information

Table 1. Ordering information

Type number	Package		Version
	Name	Description	
DAC1201D125HL	LQFP48	plastic low profile quad flat package; 48 leads; body 7 × 7 × 1.4 mm	SOT313-2

5. Block diagram

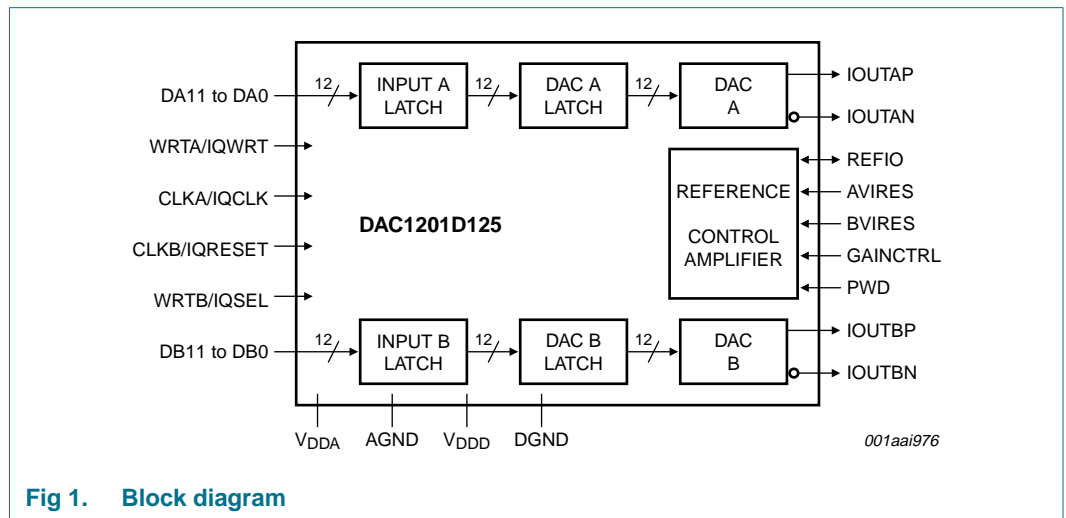

Fig 1. Block diagram

6. Pinning information

6.1 Pinning

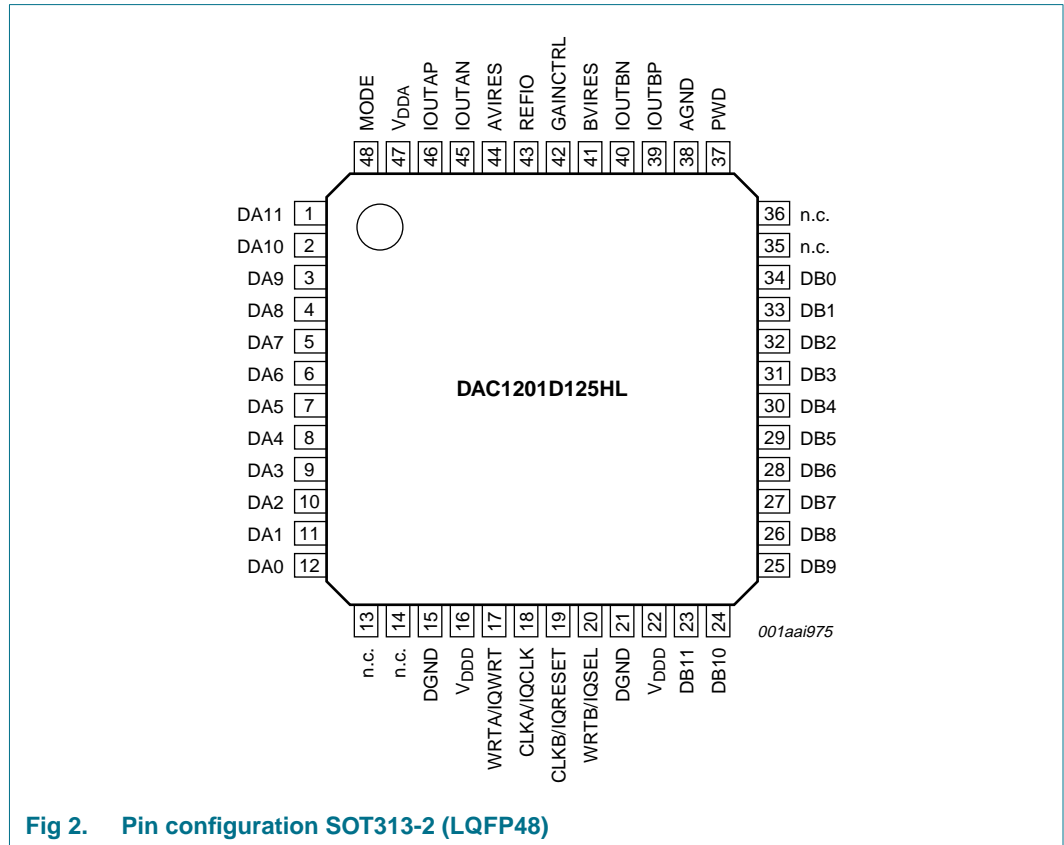

Fig 2. Pin configuration SOT313-2 (LQFP48)

6.2 Pin description

Table 2. Pin description

Symbol	Pin	Type ^[1]	Description
DA11	1	I	DAC A, data input bit 11 (MSB)
DA10	2	I	DAC A, data input bit 10
DA9	3	I	DAC A, data input bit 9
DA8	4	I	DAC A, data input bit 8
DA7	5	I	DAC A, data input bit 7
DA6	6	I	DAC A, data input bit 6
DA5	7	I	DAC A, data input bit 5
DA4	8	I	DAC A, data input bit 4
DA3	9	I	DAC A, data input bit 3
DA2	10	I	DAC A, data input bit 2
DA1	11	I	DAC A, data input bit 1
DA0	12	I	DAC A, data input bit 0 (LSB)
n.c.	13		not connected

Table 2. Pin description ...continued

Symbol	Pin	Type ^[1]	Description
n.c.	14		not connected
DGND	15	G	digital ground
V _{DD}	16	S	digital supply voltage
WRTA/IQWRT	17	I	input write port A/input write IQ in Interleaved mode
CLKA/IQCLK	18	I	input clock port A/input clock IQ in Interleaved mode
CLKB/IQRESET	19	I	input clock port B/reset IQ in Interleaved mode
WRTB/IQSEL	20	I	input write port B/select IQ in Interleaved mode
DGND	21	G	digital ground
V _{DD}	22	S	digital supply voltage
DB11	23	I	DAC B, data input bit 11 (MSB)
DB10	24	I	DAC B, data input bit 10
DB9	25	I	DAC B, data input bit 9
DB8	26	I	DAC B, data input bit 8
DB7	27	I	DAC B, data input bit 7
DB6	28	I	DAC B, data input bit 6
DB5	29	I	DAC B, data input bit 5
DB4	30	I	DAC B, data input bit 4
DB3	31	I	DAC B, data input bit 3
DB2	32	I	DAC B, data input bit 2
DB1	33	I	DAC B, data input bit 1
DB0	34	I	DAC B, data input bit 0 (LSB)
n.c.	35		not connected
n.c.	36		not connected
PWD	37	I	Power-down mode enable input
AGND	38	S	analog ground
IOU _T BP	39	O	DAC B current output
IOU _T BN	40	O	complementary DAC B current output
BVIRE _S	41	I	adjust DAC B for full-scale output current
GA _I NCTRL	42	I	gain control mode enable input
REFIO	43	I/O	reference voltage input/output
AVIRE _S	44	I	adjust DAC A for full-scale output current
IOU _T AN	45	O	complementary DAC A current output
IOU _T AP	46	O	DAC A current output
V _{DDA}	47	S	analog supply voltage
MODE	48	I	select between Dual-port or Interleaved mode

[1] Type description: S = Supply; G = Ground; I = Input; O = Output; I/O = Input/Output.

7. Limiting values

Table 3. Limiting values

In accordance with the Absolute Maximum Rating System (IEC 60134).

Symbol	Parameter	Conditions	Min	Max	Unit
V _{DDD}	digital supply voltage		[1] -0.3	+5.0	V
V _{DDA}	analog supply voltage		[1] -0.3	+5.0	V
ΔV _{DD}	supply voltage difference	between analog and digital supply voltage	-150	+150	mV
V _I	input voltage	digital inputs referenced to DGND	-0.3	+5.5	V
		pins REFIO, AVIRES, BVIRES referenced to AGND	-0.3	+5.5	V
V _O	output voltage	pins IOUTAP, IOUTAN, IOUTBP and IOUTBN referenced to AGND	-0.3	V _{DDA} + 0.3	V
T _{stg}	storage temperature		-55	+150	°C
T _{amb}	ambient temperature		-40	+85	°C
T _j	junction temperature		-	125	°C

[1] All supplies are connected together.

8. Thermal characteristics

Table 4. Thermal characteristics

Symbol	Parameter	Conditions	Typ	Unit
R _{th(j-a)}	thermal resistance from junction to ambient	in free air	89.3	K/W
R _{th(c-a)}	thermal resistance from case to ambient	in free air	60.6	K/W

9. Characteristics

Table 5. Characteristics

V_{DDD} = V_{DDA} = 3.3 V; AGND and DGND connected together; I_{O(fs)} = 20 mA and T_{amb} = -40 °C to +85 °C; typical values measured at T_{amb} = 25 °C.

Symbol	Parameter	Conditions	Min	Typ	Max	Unit
Supplies						
V _{DDD}	digital supply voltage		3.0	3.3	3.65	V
V _{DDA}	analog supply voltage		3.0	3.3	3.65	V
I _{DDD}	digital supply current	f _s = 65 Msps, f _o = 1 MHz, V _{DD} = 3.0 V to 3.6 V	-	6	7	mA
I _{DDA}	analog supply current	f _s = 65 Msps, f _o = 1 MHz, V _{DD} = 3.0 V to 3.6 V	-	50	65	mA
P _{tot}	total power dissipation	f _s = 65 Msps, f _o = 1 MHz, V _{DD} = 3.0 V to 3.6 V	-	185	260	mW
P _{pd}	power dissipation in power-down mode		-	16.5	-	mW

Table 5. Characteristics ...continued

$V_{DDD} = V_{DDA} = 3.3$ V; AGND and DGND connected together; $I_{O(fs)} = 20$ mA and $T_{amb} = -40$ °C to $+85$ °C; typical values measured at $T_{amb} = 25$ °C.

Symbol	Parameter	Conditions	Min	Typ	Max	Unit
Digital inputs						
V_{IL}	LOW-level input voltage		DGND	-	0.9	V
V_{IH}	HIGH-level input voltage		1.3	-	V_{DDD}	V
I_{IL}	LOW-level input current	$V_{IL} = 0.9$ V	-	5	-	μA
I_{IH}	HIGH-level input current	$V_{IH} = 1.3$ V	-	5	-	μA
C_i	input capacitance		[1] -	5	-	pF
Analog outputs (IOUTAP, IOUTAN, IOUTBP and IOUTBN)						
$I_{O(fs)}$	full-scale output current	differential outputs	2	-	20	mA
V_O	output voltage	compliance range	[1] -1	-	+1.25	V
R_o	output resistance		[1] -	150	-	kΩ
C_o	output capacitance		[1] -	3	-	pF
Reference voltage input/output (REFIO)						
$V_{O(ref)}$	reference output voltage		1.25	1.26	1.27	V
$I_{O(ref)}$	reference output current		[1] -	100	-	nA
V_i	input voltage	compliance range	1.0	-	1.26	V
R_i	input resistance		-	1	-	MΩ
Input timing, see Figure 18						
f_s	sampling frequency		-	-	125	Msps
$t_{w(WRT)}$	WRT pulse width	pins WRTA, WRTB	2	-	-	ns
$t_{w(CLK)}$	CLK pulse width	pins CLKA, CLKB	2	-	-	ns
$t_{h(i)}$	input hold time		1	-	-	ns
$t_{su(i)}$	input set-up time		1.8	-	-	ns
Output timing (IOUTAP, IOUTAN, IOUTBP and IOUTBN)						
t_d	delay time		-	1	-	ns
t_t	transition time	rising or falling transition (10 % to 90 % or 90 % to 10 %)	[1] -	0.6	-	ns
t_s	settling time	±1 LSB	[1] -	40	-	ns
Static linearity						
INL	integral non-linearity	25 °C	±0.4	±0.55	±0.70	LSB
		-40 °C to +85 °C	±0.3	-	±0.75	LSB
DNL	differential non-linearity	-40 °C to +85 °C	±0.15	±0.2	±0.3	LSB
Static accuracy (relative to full-scale)						
E_{offset}	offset error		-0.02	-	+0.02	%
E_G	gain error	with external reference	-1.9	±1.5	+2.5	%
		with internal reference	-2.9	±2.1	+2.9	%
ΔG	gain mismatch	between DAC A and DAC B	-0.36	±0.05	+0.36	%

Table 5. Characteristics ...continued

$V_{DD} = V_{DDA} = 3.3\text{ V}$; AGND and DGND connected together; $I_{O(f_s)} = 20\text{ mA}$ and $T_{amb} = -40\text{ }^\circ\text{C}$ to $+85\text{ }^\circ\text{C}$; typical values measured at $T_{amb} = 25\text{ }^\circ\text{C}$.

Symbol	Parameter	Conditions	Min	Typ	Max	Unit	
Dynamic performance							
SFDR	spurious free dynamic range	B = Nyquist					
		$f_s = 52\text{ Msps}$; $f_o = 1\text{ MHz}$					
		0 dBFS	-	81	-	dBc	
		-6 dBFS	-	80	-	dBc	
		-12 dBFS	-	74	-	dBc	
		$f_s = 52\text{ Msps}$; 0 dBFS					
		$f_o = 5.24\text{ MHz}$	-	79	-	dBc	
		$f_s = 78\text{ Msps}$; 0 dBFS					
		$f_o = 10.4\text{ MHz}$	-	78	-	dBc	
		$f_o = 15.7\text{ MHz}$	-	71	-	dBc	
		$f_s = 100\text{ Msps}$; 0 dBFS					
		$f_o = 5.04\text{ MHz}$	-	77	-	dBc	
		$f_o = 20.2\text{ MHz}$	60	69	-	dBc	
		$f_s = 125\text{ Msps}$; 0 dBFS					
		$f_o = 20.1\text{ MHz}$	-	68	-	dBc	
within a window							
$f_s = 52\text{ Msps}$; $f_o = 1\text{ MHz}$; 2 MHz span	-	89	-	dBc			
$f_s = 52\text{ Msps}$; $f_o = 5.24\text{ MHz}$; 10 MHz span	-	87	-	dBc			
$f_s = 78\text{ Msps}$; $f_o = 5.26\text{ MHz}$; 2 MHz span	-	90	-	dBc			
$f_s = 125\text{ Msps}$; $f_o = 5.04\text{ MHz}$; 10 MHz span	79	90	-	dBc			
THD	total harmonic distortion	$f_s = 52\text{ Msps}$; $f_o = 1\text{ MHz}$	-	-78	-	dBc	
		$f_s = 78\text{ Msps}$; $f_o = 5.26\text{ MHz}$	-	-76	-	dBc	
		$f_s = 100\text{ Msps}$; $f_o = 5.04\text{ MHz}$	-	-74	-	dBc	
		$f_s = 125\text{ Msps}$; $f_o = 20.1\text{ MHz}$	-	-64	-60	dBc	
MTPR	multitone power ratio	$f_s = 65\text{ Msps}$; 2 MHz < f_o < 2.99 MHz; 8 tones at 110 kHz spacing at 0 dB full-scale	-	80	-	dBc	
NSD	noise spectral density	$f_s = 100\text{ Msps}$; $f_o = 5.04\text{ MHz}$	-	-148.7	-	dBm/Hz	
α_{CS}	channel separation	$f_s = 78\text{ Msps}$; $f_o = 10.4\text{ MHz}$	-	88.0	-	dBc	
		$f_s = 125\text{ Msps}$; $f_o = 20.1\text{ MHz}$	-	83.5	-	dBc	

[1] Guaranteed by design.

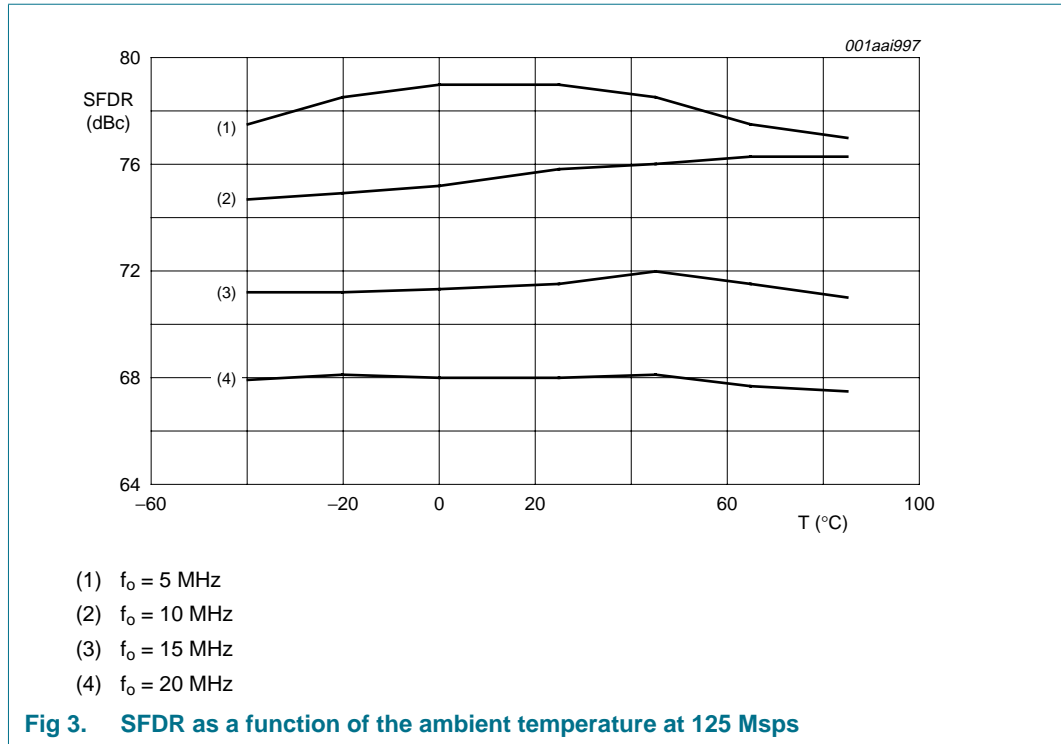

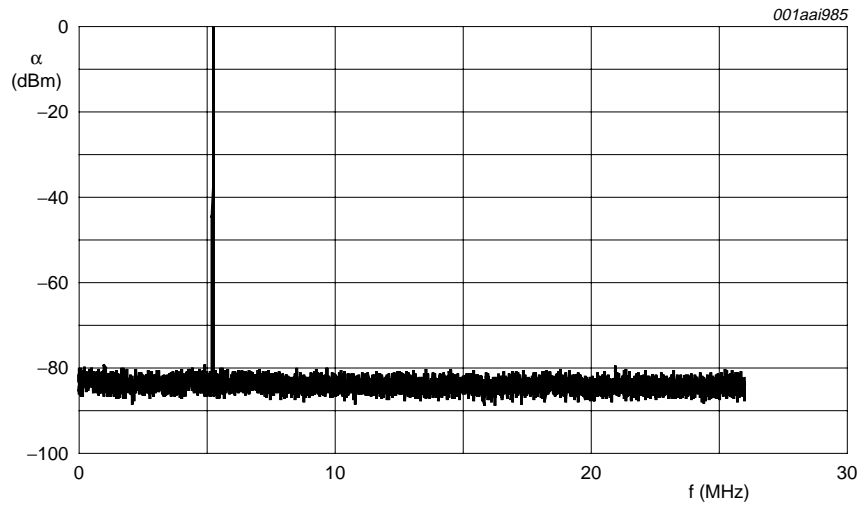

a. $f_s = 52$ Msps; $f_c = 5.24$ MHz; $\alpha = 0$ dBFS

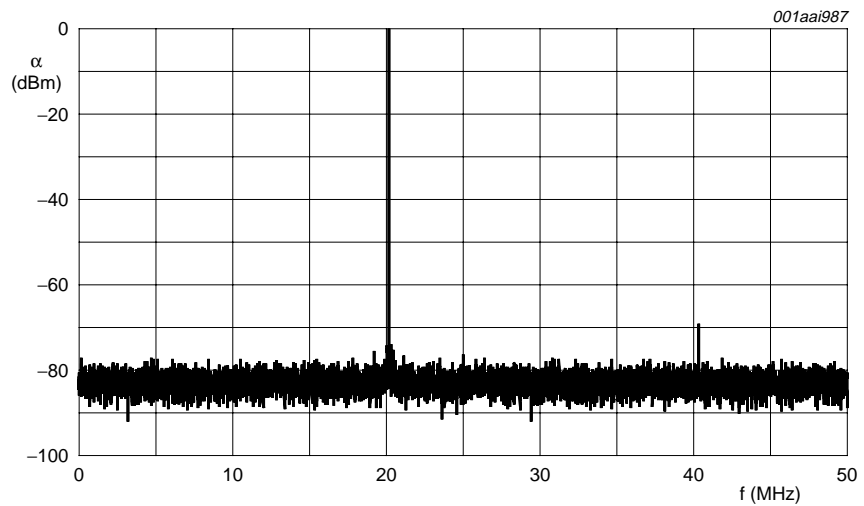

b. $f_s = 100$ Msps; $f_c = 20$ MHz; $\alpha = 0$ dBFS

Fig 4. 1-tone SFDR

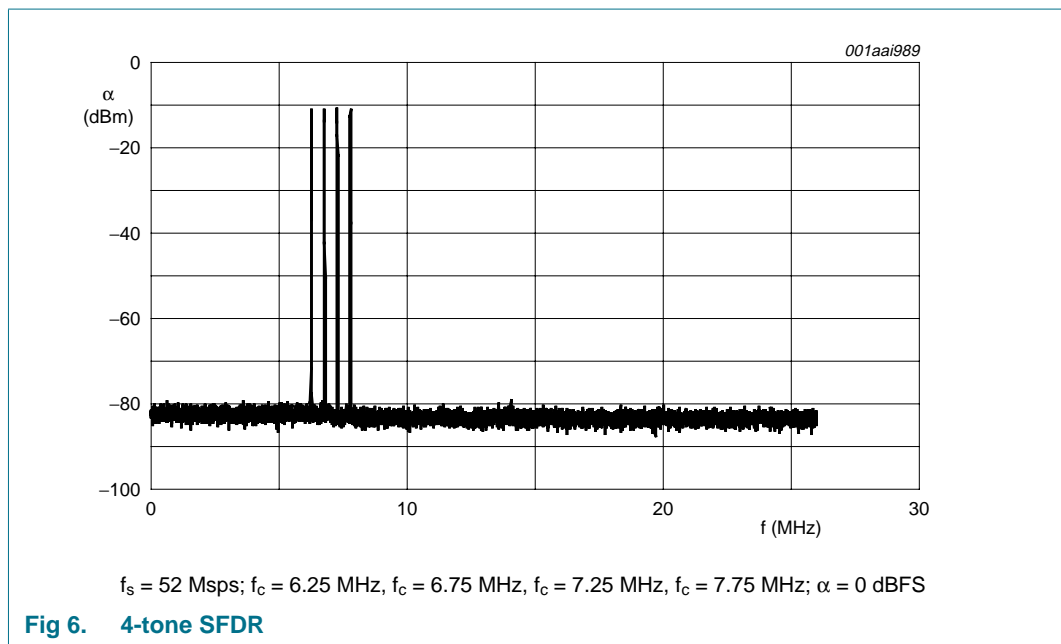
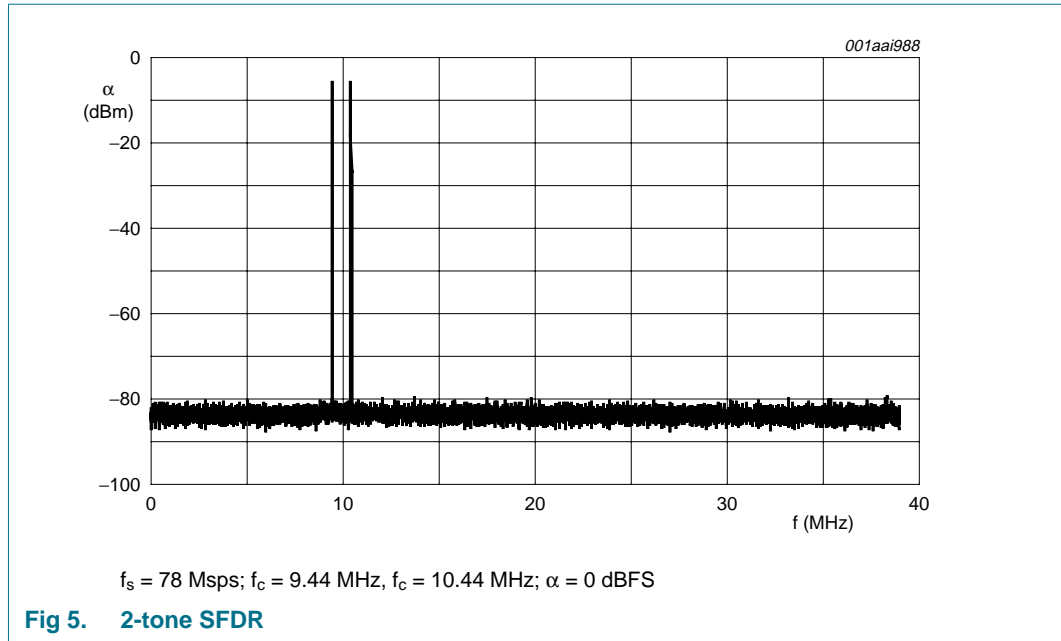

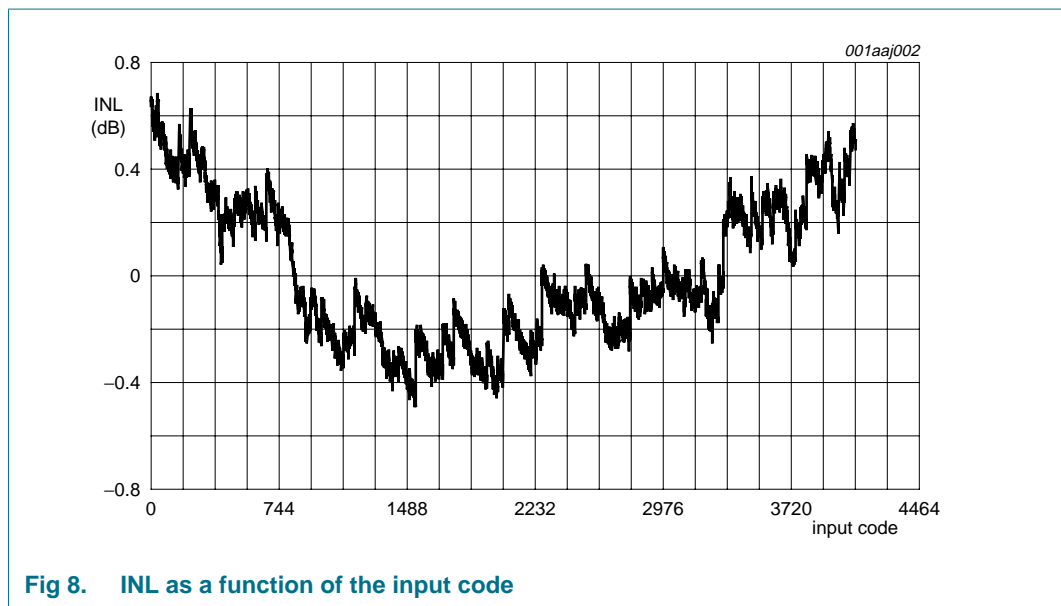
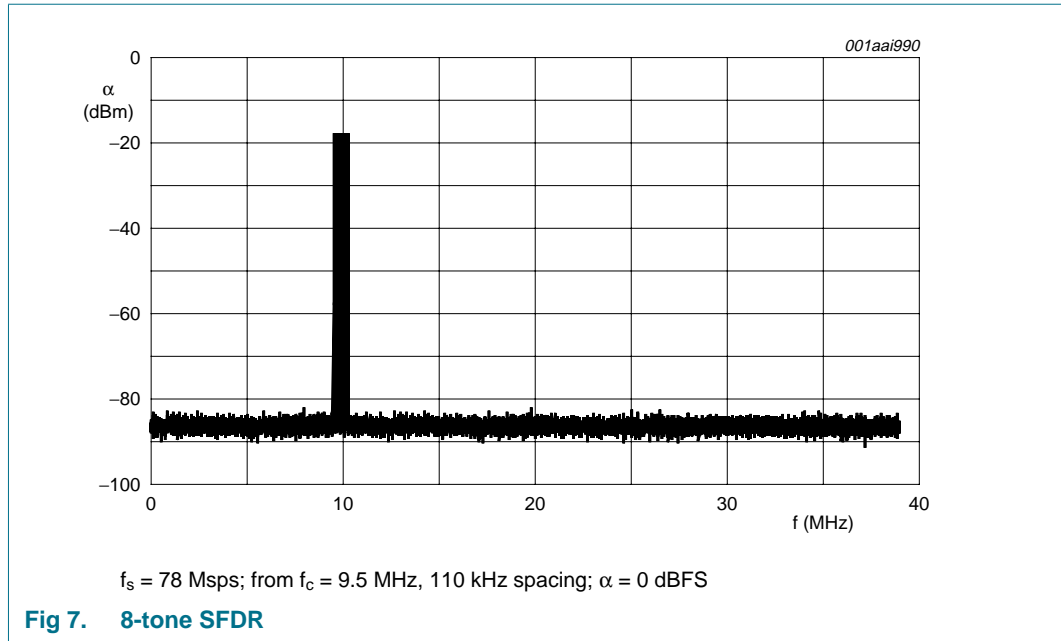

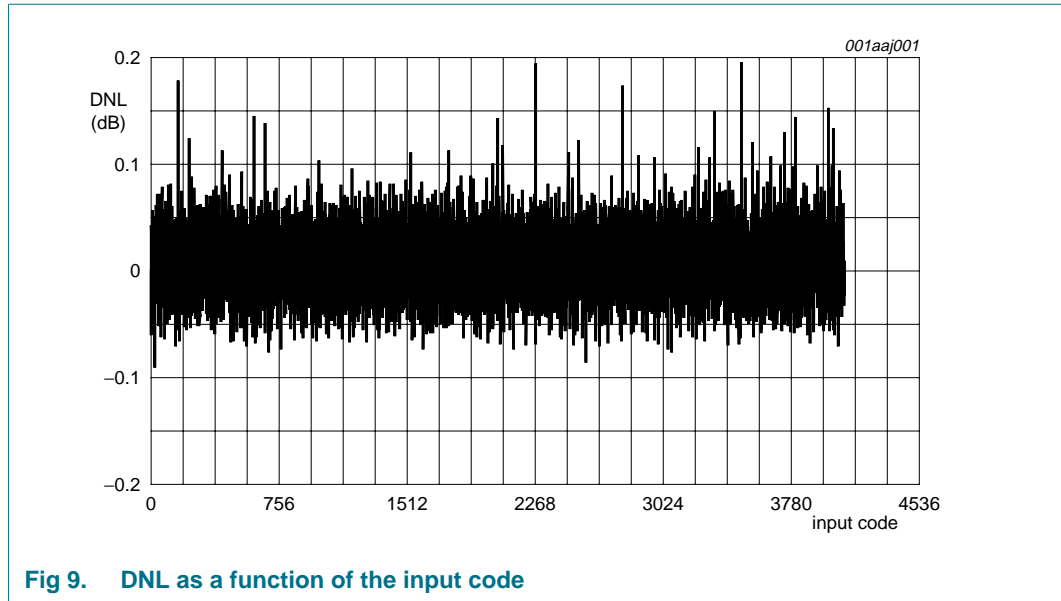

Fig 9. DNL as a function of the input code

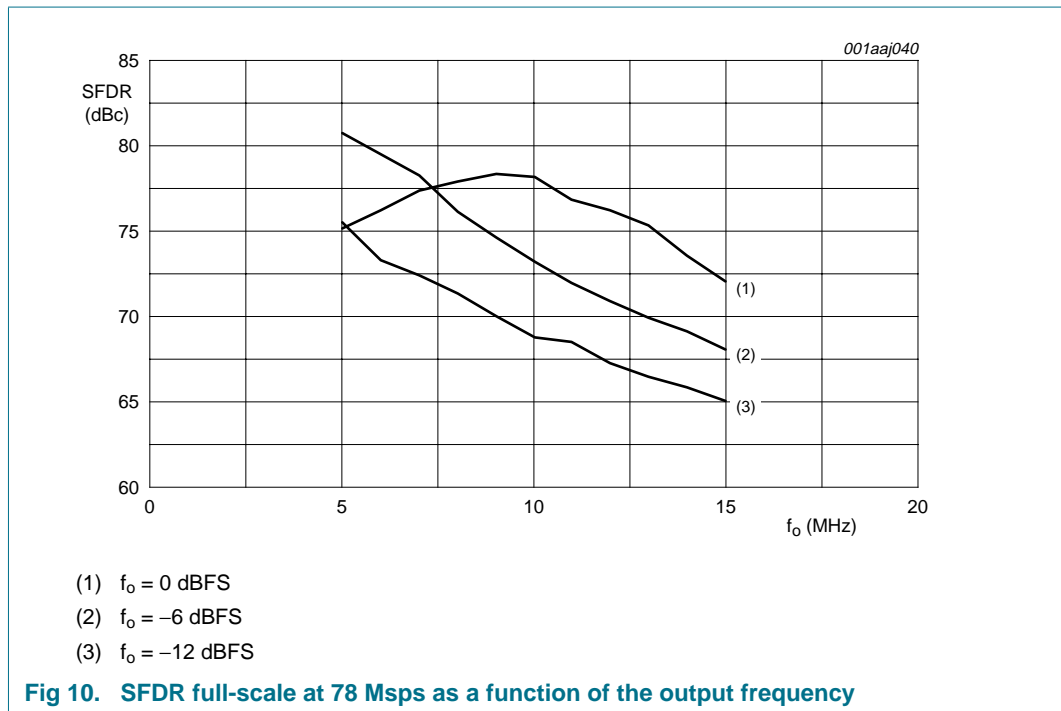
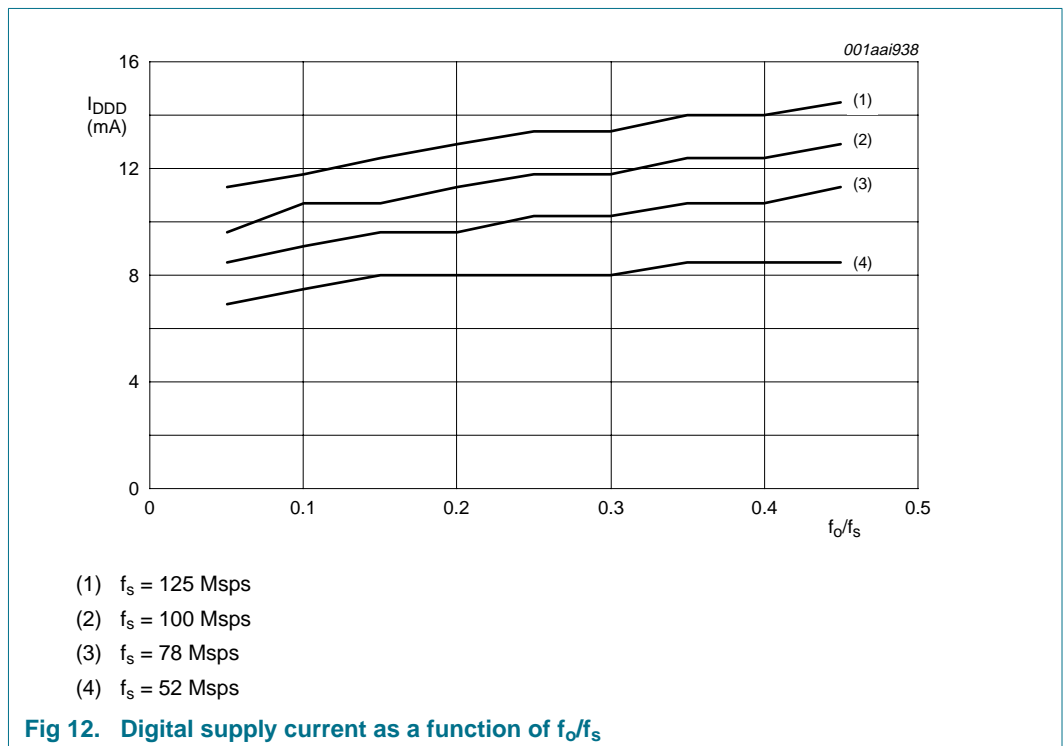
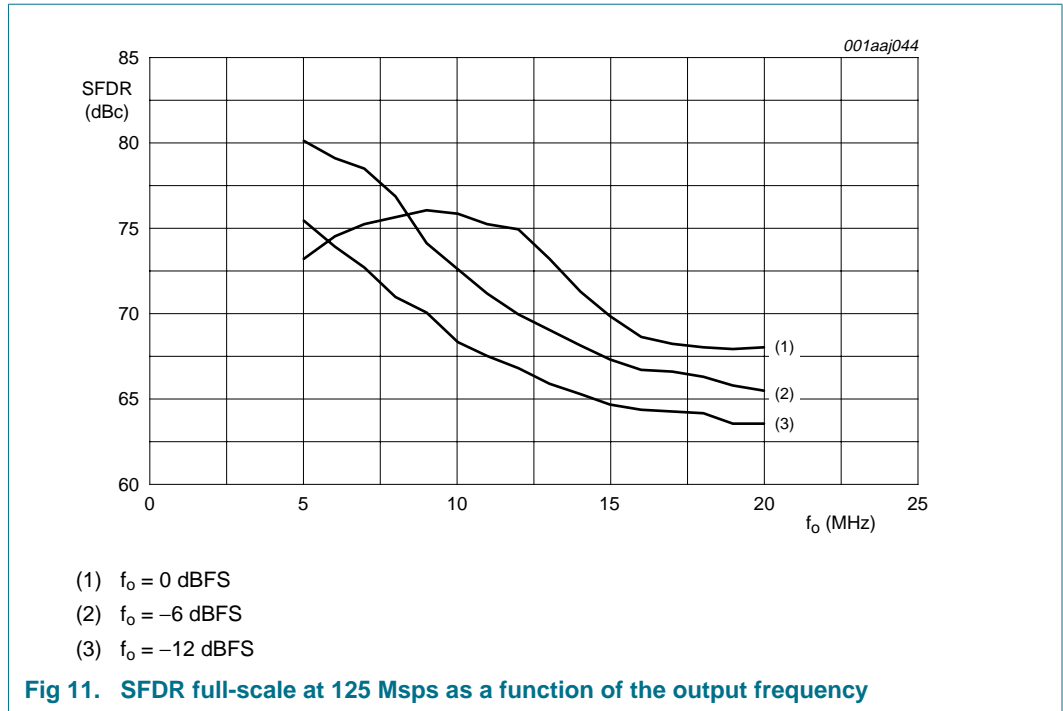

Fig 10. SFDR full-scale at 78 Mps as a function of the output frequency



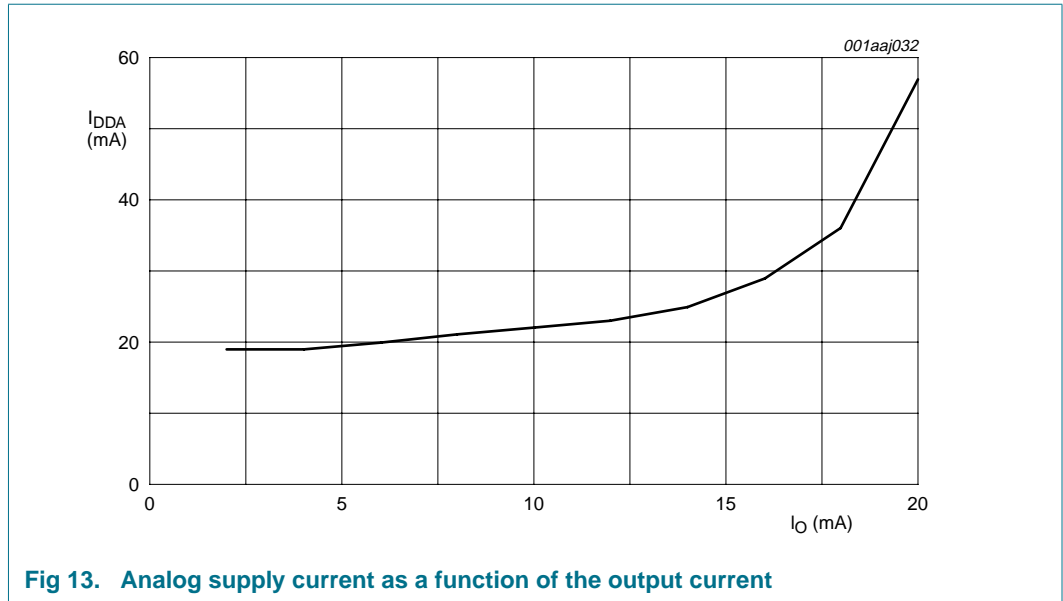

Fig 13. Analog supply current as a function of the output current

10. Application information

10.1 General description

The DAC1201D125 is a dual 12-bit DAC operating up to 125 Msp/s. Each DAC consists of a segmented architecture, comprising a 7-bit thermometer sub-DAC and a 5-bit binary weighted sub-DAC.

Two modes are available for the digital input depending on the status of pin MODE. In Dual-port mode, each DAC uses its own data input line at the same frequency as the update rate. In Interleaved mode, both DACs use the same data input line at twice the update rate.

Each DAC generates on pins IOOUTAP/IOOUTAN and IOOUTBP/IOOUTBN two complementary current outputs. This provides a full-scale output current ($I_{O(fs)}$), up to 20 mA. A single common or two independent full-scale current controls can be selected for both channels using pin GAINCTRL. An internal reference voltage is available for the reference current which is externally adjustable using pin REFIO.

The DAC1201D125 operates at 3.3 V and has separate digital and analog power supplies. Pin PWD is used to power-down the device. The digital input is 1.8 V compliant, 3.3 V compliant and 5 V tolerant.

10.2 Input data

The DAC1201D125 input follows a straight binary coding where DA11 and DB11 are the Most Significant Bits (MSB) and DA0 and DB0 are the Least Significant Bits (LSB).

The setting applied to pin MODE defines whether the DAC1201D125 operates in Dual-port mode or in Interleaved mode, (see [Table 6](#)).

Table 6. Mode selection

Mode	Function	DA11 to DA0	DB11 to DB0	Pin 17	Pin 18	Pin 19	Pin 20
LOW	Interleaved mode	active	off	IQWRT	IQCLK	IQRESET	IQSEL
HIGH	Dual-port mode	active	active	WRTA	CLKA	CLKB	WRTB

10.2.1 Dual-port mode

The data and clock circuit for Dual-port mode operation is shown in Figure 14.

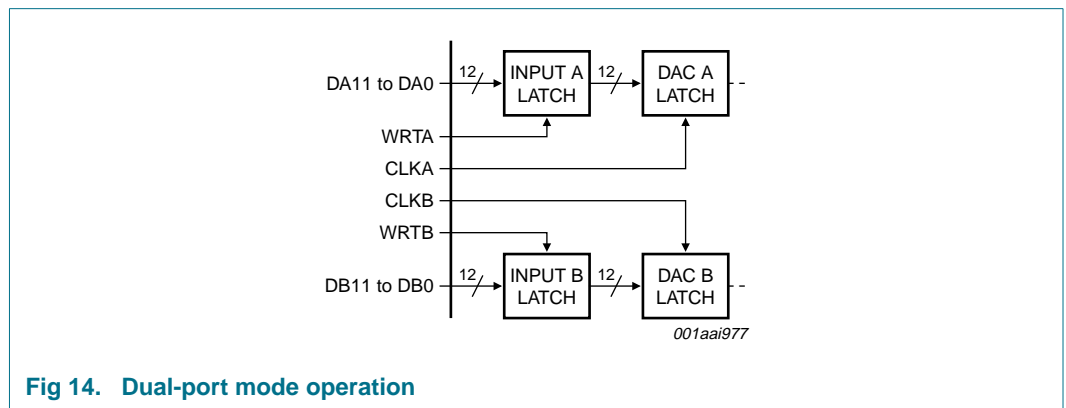

Fig 14. Dual-port mode operation

Each DAC has its own independent data and clock inputs. The data enters the input latch on the rising edge of the WRTA/WRTB signal and is transferred to the DAC latch. The output is updated on the rising edge of the CLKA/CLKB signal.

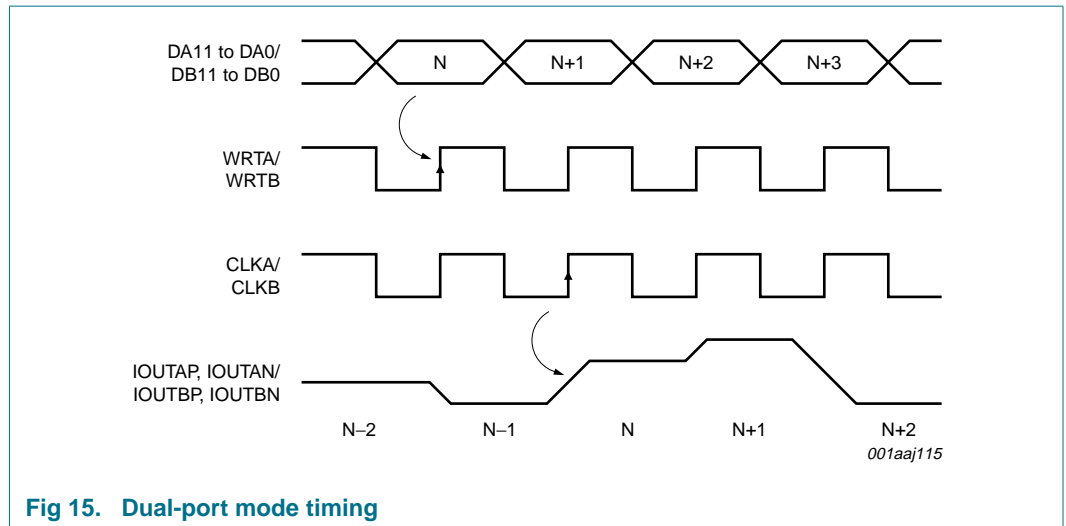

Fig 15. Dual-port mode timing

10.2.2 Interleaved mode

The data and clock circuit for Interleaved mode operation is illustrated in Figure 16.

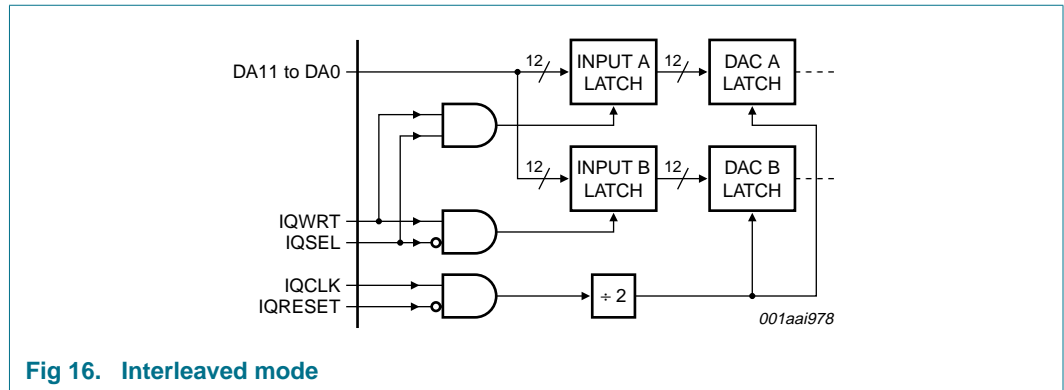

Fig 16. Interleaved mode

In Interleaved mode, both DACs use the same data and clock inputs at twice the update rate. Data enters the latch on the rising edge of IQWRT. The data is sent to either latch A or latch B, depending on the value of IQSEL. The IQSEL transition must occur when IQWRT and IQCLK are LOW.

The IQCLK is divided by 2 internally and the data is transferred to the DAC latch. It is updated on its rising edge. When IQRESET is HIGH, IQCLK is disabled, see Figure 17.

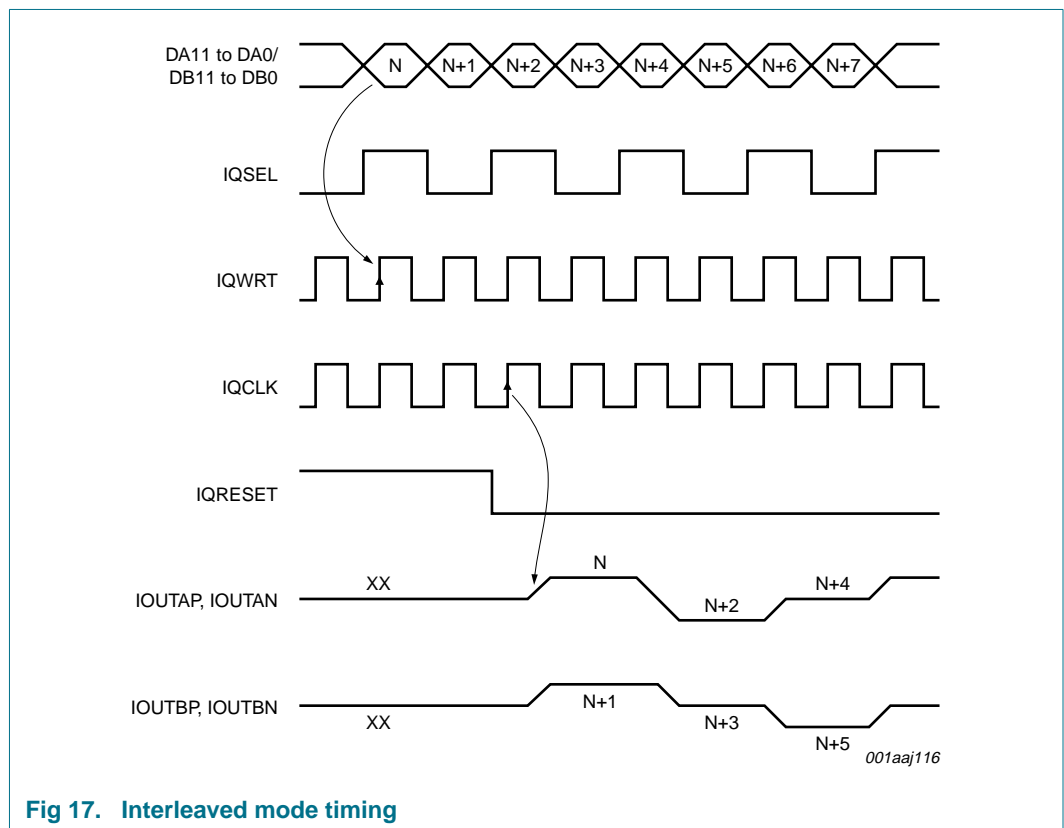

Fig 17. Interleaved mode timing

10.3 Timing

The DAC1201D125 can operate at an update rate up to 125 Msp/s. This generates an input data rate of 125 MHz in Dual-port mode and 250 MHz in Interleaved mode. The timing of the DAC1201D125 is shown in [Figure 18](#).

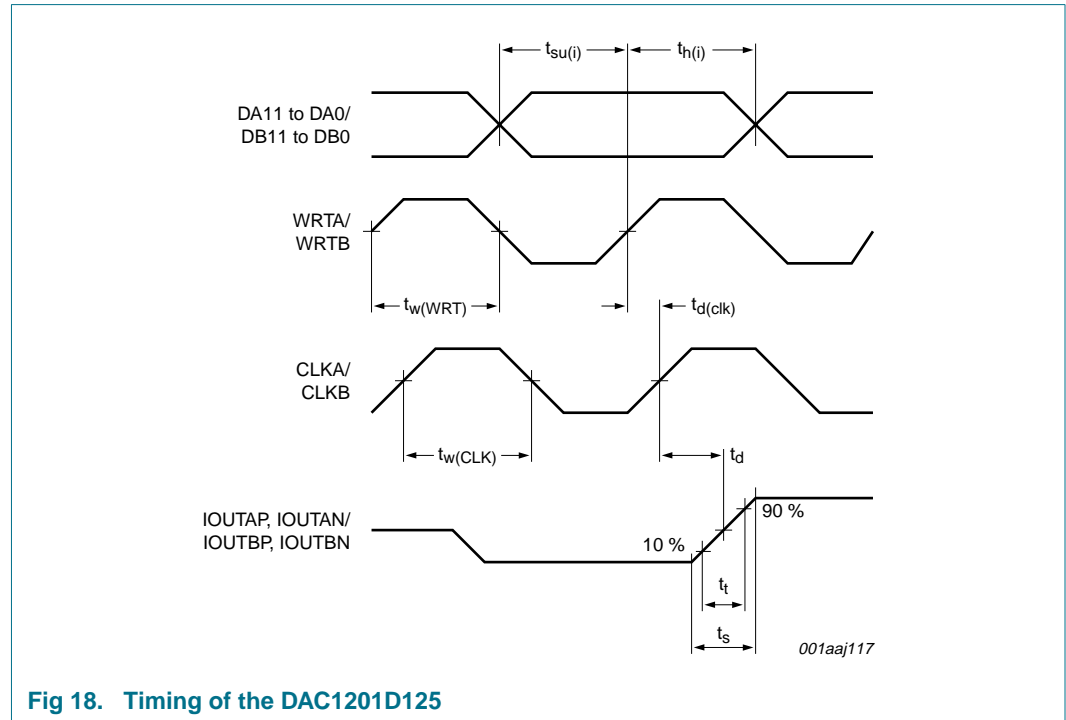

Fig 18. Timing of the DAC1201D125

The typical performances are measured at 50 % duty cycle but any timing within the limits of the characteristics will not alter the performance.

- A configuration resulting in the same timing for the signals WRTA/WRTB and CLKA/CLKB, can be achieved either by synchronizing them or by connecting them together.
- The rising edge of the CLKA/CLKB signal can also be placed in a range from half a period in front of the rising edge of the WRTA/WRTB signal to half a period minus 1 ns after the rising edge of the WRTA/WRTB signal.

A typical set-up time of 0 ns and a hold time of 0.6 ns enables the DAC1201D125 to be easily integrated into any application.

10.4 DAC transfer function

The full-scale output current for each DAC is the sum of the two complementary current outputs:

$$I_{O(fs)} = I_{IOUTP} + I_{IOUTN} \tag{1}$$

The output current depends on the digital input data:

$$I_{IOUTP} = I_{O(fs)} \times \left(\frac{DATA}{4096} \right) \quad I_{IOUTN} = I_{O(fs)} \times \left(\frac{(4095 - DATA)}{4096} \right)$$

Table 7 shows the output current as a function of the input data, when $I_{O(fs)} = 20\text{ mA}$.

Table 7. DAC transfer function

Data	DA11/DB11 to DA0/DB0	IOUTAP/IOUTBP	IOUTAN/IOUTBN
0	0000 0000 0000	0 mA	20 mA
...
2047	1000 0000 0000	10 mA	10 mA
...
4095	1111 1111 1111	20 mA	0 mA

10.5 Full-scale current adjustment

The DAC1201D125 integrates one 1.25 V reference and two current sources to adjust the full-scale current in both DACs.

The internal reference configuration is shown in Figure 19.

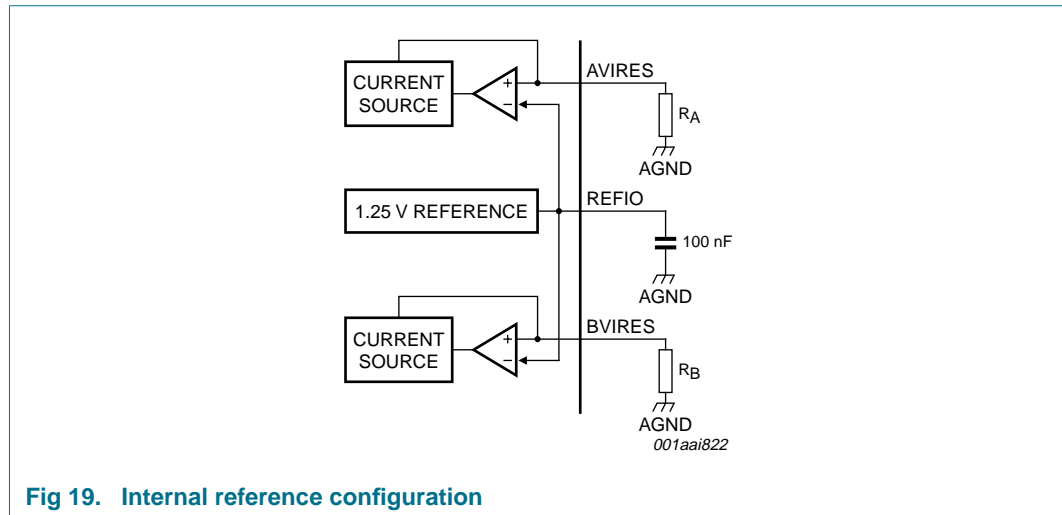

Fig 19. Internal reference configuration

The bias current is generated by the output of the internal regulator connected to the inverting input of the internal operational amplifiers. The external resistors R_A and R_B are connected to pins AVIRES and BVIRES, respectively. This configuration is optimal for temperature drift compensation because the band gap can be matched with the voltage on the feedback resistors.

The relationship between full-scale output current ($I_{O(fs)}$) at the output of channel A or channel B and the resistor is:

$$I_{O(fs)} = \frac{24V_{REFIO}}{R_A} \tag{2}$$

The output current of the two DACs is typically fixed at 20 mA when both resistors R_A and R_B are set to 1.5 kΩ. The operational range of DAC1201D125 is from 2 mA to 20 mA.

It is recommended to decouple pin REFIO using a 100 nF capacitor.

An external reference can also be used for applications requiring higher accuracy or precise current adjustment. Due to the high input impedance of pin REFIO, applying an external source disables the band gap.

10.6 Gain control

Table 8 shows how to select the different gain control modes.

Table 8. Gain control

GAINCTRL	Mode	DAC A full-scale control	DAC B full-scale control
LOW	independent gain control	AVIRES	BVIRES
HIGH	common gain control	AVIRES	AVIRES

In Independent gain mode, both full-scale currents can be adjusted independently using resistors R_A on pin AVIRES and R_B on pin BVIRES.

In Common gain mode, both full-scale currents are adjusted with the same resistor and divided by two in both DACs.

10.7 Analog outputs

See Figure 20 for the analog output circuit of one DAC. This circuit consists of a parallel combination of PMOS current sources and associated switches for each segment.

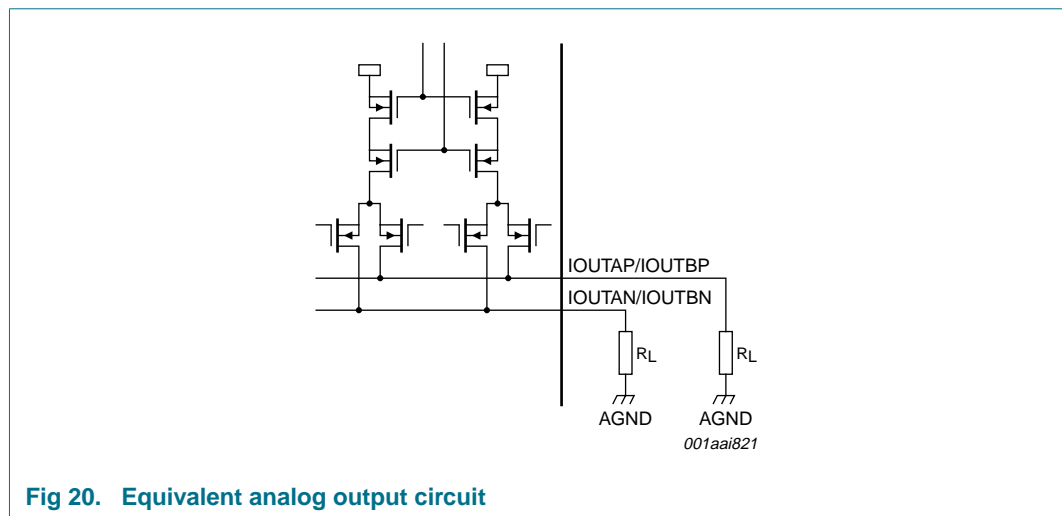

Fig 20. Equivalent analog output circuit

Cascode source configuration enables the output impedance of the source to be increased, thus improving the dynamic performance by reducing distortion.

The DAC1201D125 can be used with either:

- a differential output, coupled to a transformer (or operational amplifier) to reduce even-order harmonics and noise
- a single-ended output for applications requiring unipolar voltage

A typical configuration is to use a 1 V p-p level on each output IOUTAP/IOUTBP and IOUTAN/IOUTBN. Several combinations can be used but they must respect the voltage compliance range.

10.7.1 Differential output using transformer

The use of a differential-coupled transformer output (see Figure 21) provides optimum distortion performance, and it helps to match the impedance and provides electrical isolation.

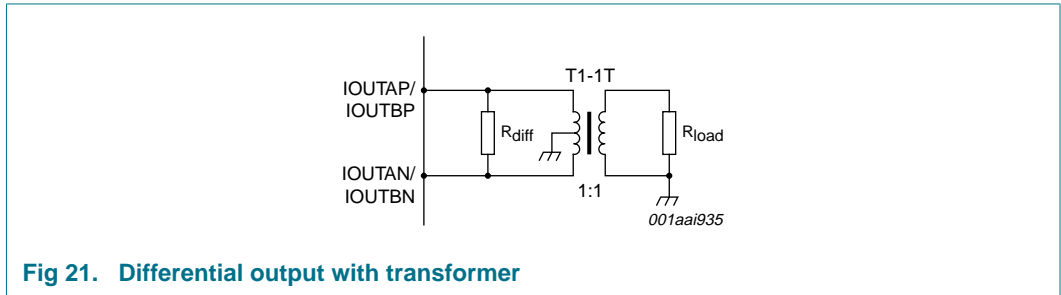

Fig 21. Differential output with transformer

The center tap is grounded to allow the DC current flow to/from both outputs. If the center tap is open, the differential resistor must be replaced by two resistors connected to ground.

10.7.2 Single-ended output

Using a single load resistor on one current output will provide a unipolar output range, typically from 0 V to 0.5 V with a 20 mA full-scale current at a 50 Ω load.

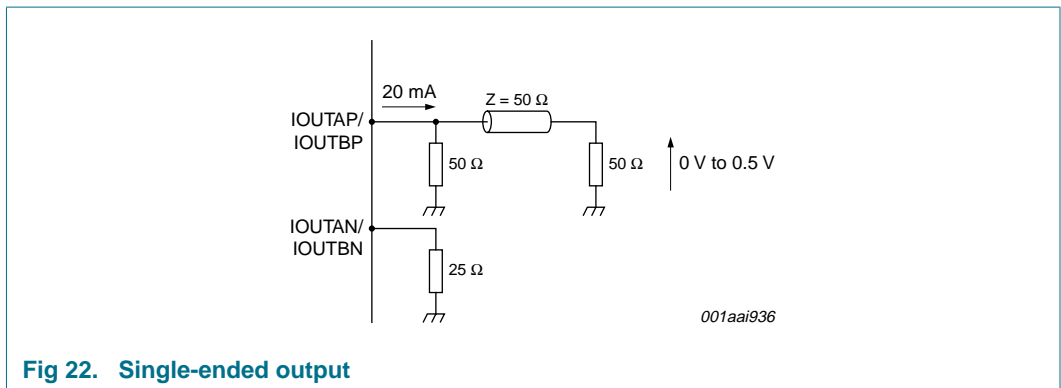

Fig 22. Single-ended output

The resistor on the other current output is 25 Ω.

10.8 Power-down function

The DAC1201D125 has a power-down function to reduce the power consumption when it is not active.

Table 9. Power-down

PWD	Device function	Power dissipation (typ)
LOW	active	185 mW
HIGH	not active	16.5 mW

10.9 Alternative devices

The following alternative devices are also available.

Table 10. Alternative devices

Pin compatible

Type number	Description	Sampling frequency
DAC1001D125	dual 10-bit DAC	up to 125 Msps
DAC1401D125	dual 14-bit DAC	up to 125 Msps

10.10 Application diagram

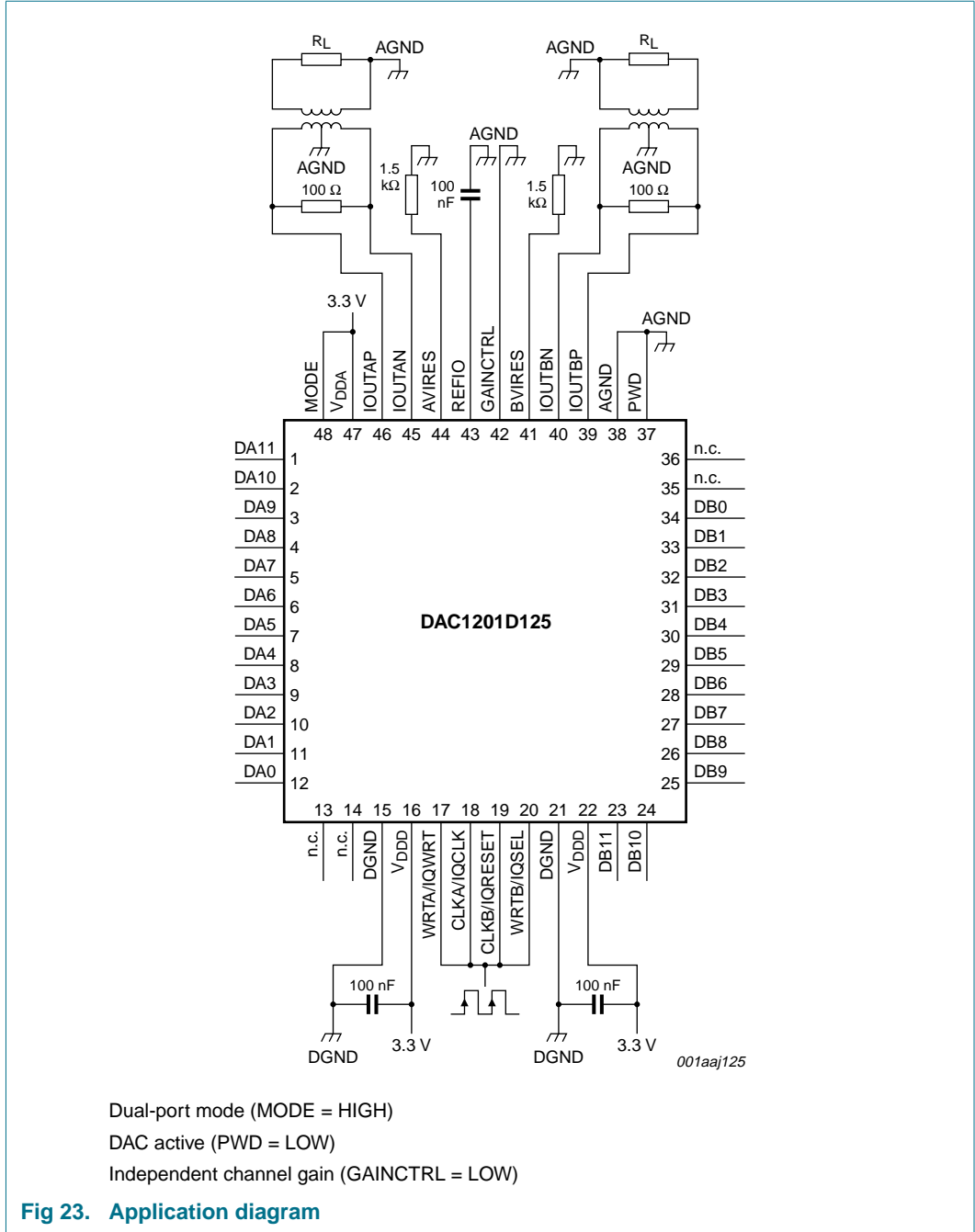

11. Package outline

LQFP48: plastic low profile quad flat package; 48 leads; body 7 x 7 x 1.4 mm

SOT313-2

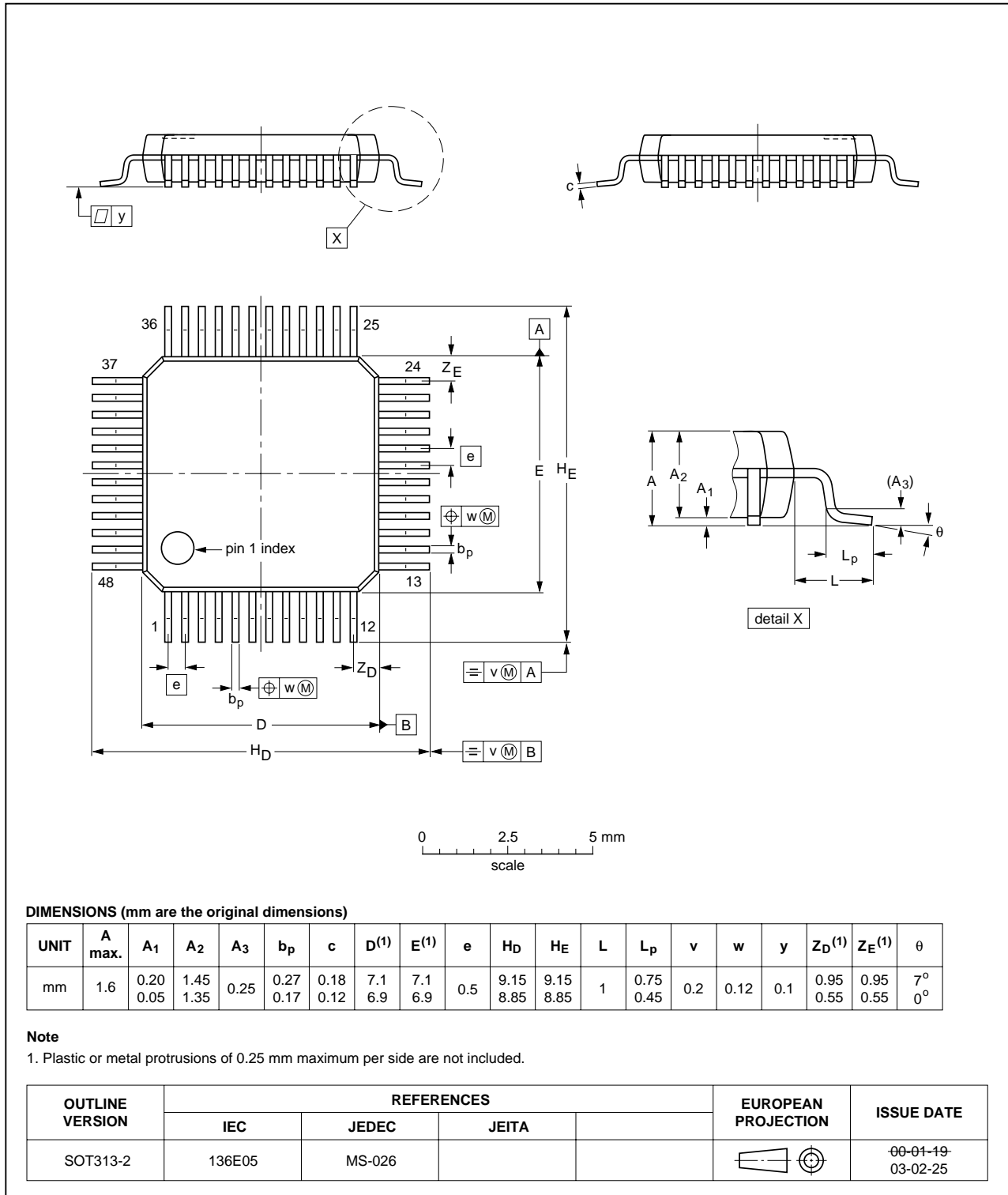

Fig 24. Package outline SOT313-2 (LQFP48)

12. Abbreviations

Table 11. Abbreviations

Acronym	Description
DNL	Differential Non-Linearity
dBFS	decibel Full-Scale
IF	Intermediate Frequency
INL	Integral Non-Linearity
LSB	Least Significant Bit
MSB	Most Significant Bit
PMOS	Positive-channel Metal-Oxide Semiconductor
SFDR	Spurious-Free Dynamic Range

13. Revision history

Table 12. Revision history

Document ID	Release date	Data sheet status	Change notice	Supersedes
DAC1201D125_1	20081127	Product data sheet	-	-

14. Legal information

14.1 Data sheet status

Document status ^{[1][2]}	Product status ^[3]	Definition
Objective [short] data sheet	Development	This document contains data from the objective specification for product development.
Preliminary [short] data sheet	Qualification	This document contains data from the preliminary specification.
Product [short] data sheet	Production	This document contains the product specification.

[1] Please consult the most recently issued document before initiating or completing a design.

[2] The term 'short data sheet' is explained in section "Definitions".

[3] The product status of device(s) described in this document may have changed since this document was published and may differ in case of multiple devices. The latest product status information is available on the Internet at URL <http://www.nxp.com>.

14.2 Definitions

Draft — The document is a draft version only. The content is still under internal review and subject to formal approval, which may result in modifications or additions. NXP Semiconductors does not give any representations or warranties as to the accuracy or completeness of information included herein and shall have no liability for the consequences of use of such information.

Short data sheet — A short data sheet is an extract from a full data sheet with the same product type number(s) and title. A short data sheet is intended for quick reference only and should not be relied upon to contain detailed and full information. For detailed and full information see the relevant full data sheet, which is available on request via the local NXP Semiconductors sales office. In case of any inconsistency or conflict with the short data sheet, the full data sheet shall prevail.

14.3 Disclaimers

General — Information in this document is believed to be accurate and reliable. However, NXP Semiconductors does not give any representations or warranties, expressed or implied, as to the accuracy or completeness of such information and shall have no liability for the consequences of use of such information.

Right to make changes — NXP Semiconductors reserves the right to make changes to information published in this document, including without limitation specifications and product descriptions, at any time and without notice. This document supersedes and replaces all information supplied prior to the publication hereof.

Suitability for use — NXP Semiconductors products are not designed, authorized or warranted to be suitable for use in medical, military, aircraft, space or life support equipment, nor in applications where failure or

malfunction of an NXP Semiconductors product can reasonably be expected to result in personal injury, death or severe property or environmental damage. NXP Semiconductors accepts no liability for inclusion and/or use of NXP Semiconductors products in such equipment or applications and therefore such inclusion and/or use is at the customer's own risk.

Applications — Applications that are described herein for any of these products are for illustrative purposes only. NXP Semiconductors makes no representation or warranty that such applications will be suitable for the specified use without further testing or modification.

Limiting values — Stress above one or more limiting values (as defined in the Absolute Maximum Ratings System of IEC 60134) may cause permanent damage to the device. Limiting values are stress ratings only and operation of the device at these or any other conditions above those given in the Characteristics sections of this document is not implied. Exposure to limiting values for extended periods may affect device reliability.

Terms and conditions of sale — NXP Semiconductors products are sold subject to the general terms and conditions of commercial sale, as published at <http://www.nxp.com/profile/terms>, including those pertaining to warranty, intellectual property rights infringement and limitation of liability, unless explicitly otherwise agreed to in writing by NXP Semiconductors. In case of any inconsistency or conflict between information in this document and such terms and conditions, the latter will prevail.

No offer to sell or license — Nothing in this document may be interpreted or construed as an offer to sell products that is open for acceptance or the grant, conveyance or implication of any license under any copyrights, patents or other industrial or intellectual property rights.

14.4 Trademarks

Notice: All referenced brands, product names, service names and trademarks are the property of their respective owners.

15. Contact information

For more information, please visit: <http://www.nxp.com>

For sales office addresses, please send an email to: salesaddresses@nxp.com

16. Contents

1	General description	1
2	Features	1
3	Applications	1
4	Ordering information	2
5	Block diagram	2
6	Pinning information	3
6.1	Pinning	3
6.2	Pin description	3
7	Limiting values	5
8	Thermal characteristics	5
9	Characteristics	5
10	Application information	14
10.1	General description	14
10.2	Input data	14
10.2.1	Dual-port mode	15
10.2.2	Interleaved mode	16
10.3	Timing	17
10.4	DAC transfer function	17
10.5	Full-scale current adjustment	18
10.6	Gain control	19
10.7	Analog outputs	19
10.7.1	Differential output using transformer	20
10.7.2	Single-ended output	20
10.8	Power-down function	20
10.9	Alternative devices	21
10.10	Application diagram	22
11	Package outline	23
12	Abbreviations	24
13	Revision history	24
14	Legal information	25
14.1	Data sheet status	25
14.2	Definitions	25
14.3	Disclaimers	25
14.4	Trademarks	25
15	Contact information	25
16	Contents	26

Please be aware that important notices concerning this document and the product(s) described herein, have been included in section 'Legal information'.

founded by

PHILIPS

© NXP B.V. 2008.

All rights reserved.

For more information, please visit: <http://www.nxp.com>

For sales office addresses, please send an email to: salesaddresses@nxp.com

Date of release: 27 November 2008

Document identifier: DAC1201D125_1