



TJA1081

FlexRay node transceiver

Rev. 03 — 4 September 2009

Product data sheet

1. General description

The TJA1081 is a FlexRay node transceiver that is fully compliant with the FlexRay electrical physical layer specification V2.1 Rev. A (see [Ref. 1](#)) and partly complies with versions V2.1 Rev. B. In addition, the TJA1081 already incorporates features and parameters anticipated to be included in V3.0, currently being finalized. It is primarily intended for communication systems from 1 Mbit/s to 10 Mbit/s, and provides an advanced interface between the protocol controller and the physical bus in a FlexRay network.

The TJA1081 features enhanced low-power modes, optimized for ECUs that are permanently connected to the battery.

The TJA1081 provides differential transmit capability to the network and differential receive capability to the FlexRay controller. It offers excellent EMC performance as well as high ESD protection.

The TJA1081 actively monitors system performance using dedicated error and status information (that can be read by any microcontroller), along with internal voltage and temperature monitoring.

The TJA1081 supports mode control as used in the TJA1080A (see [Ref. 2](#)).

2. Features

2.1 Optimized for time triggered communication systems

- Compliant with FlexRay electrical physical layer specification V2.1 Rev. A (see [Ref. 1](#))
- Automotive product qualification in accordance with AEC-Q100
- Data transfer up to 10 Mbit/s
- Support of 60 ns minimum bit time
- Very low ElectroMagnetic Emission (EME) to support unshielded cable
- Differential receiver with wide common-mode range for high ElectroMagnetic Immunity (EMI)
- Auto I/O level adaptation to host controller supply voltage V_{IO}
- Can be used in 14 V and 42 V powered systems
- Bus guardian interface
- Independent power supply ramp-up for V_{BAT} , V_{CC} and V_{IO}

2.2 Low power management

- Low power management including inhibit switch
- Very low current in Sleep and Standby modes

- Local and remote wake-up
- Supports remote wake-up via dedicated data frames
- Wake-up source recognition

2.3 Diagnosis (detection and signalling)

- Overtemperature detection
- Short-circuit on bus lines
- V_{BAT} power-on flag (first battery connection and cold start)
- Pin TXEN and pin BGE clamping
- Undervoltage detection on pins V_{BAT} , V_{CC} and V_{IO}
- Wake source indication

2.4 Protections

- Bus pins protected against ± 8 kV HBM ESD pulses
- Bus pins protected against transients in automotive environment (ISO 7637 class C compliant)
- Bus pins short-circuit proof to battery voltage (14 V and 42 V) and ground
- Fail-silent behavior in the event of an undervoltage on pins V_{BAT} , V_{CC} or V_{IO}
- Passive behavior of bus lines while the transceiver is not powered

2.5 Functional classes according to FlexRay electrical physical layer specification (see [Ref. 1](#))

- Bus driver voltage regulator control
- Bus driver - bus guardian control interface
- Bus driver logic level adaptation

3. Ordering information

Table 1. Ordering information

Type number	Package		Version
	Name	Description	
TJA1081TS	SSOP16	SSOP16: plastic shrink small outline package; 16 leads; body width 5.3 mm	SOT338-1

4. Block diagram

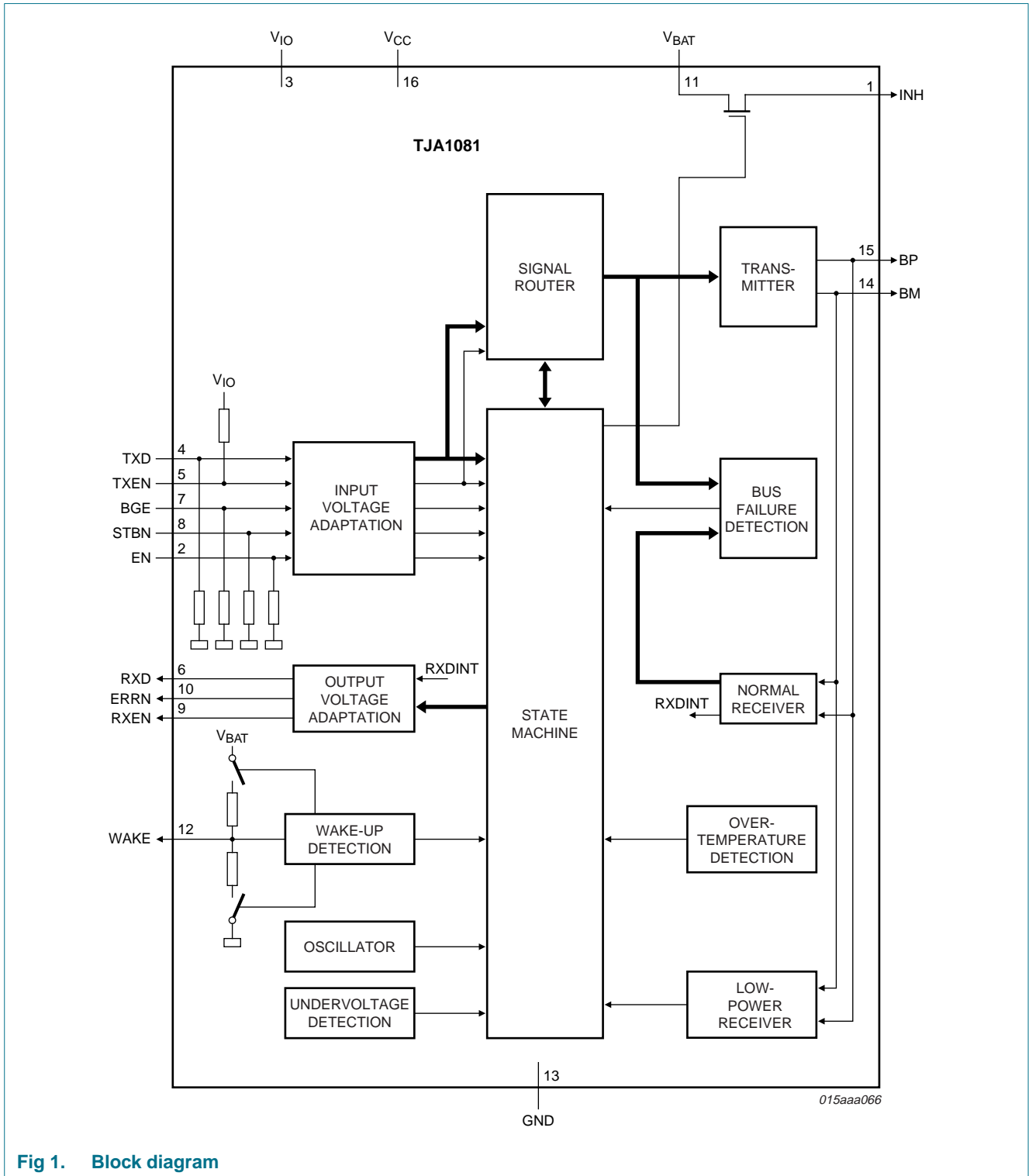

Fig 1. Block diagram

5. Pinning information

5.1 Pinning

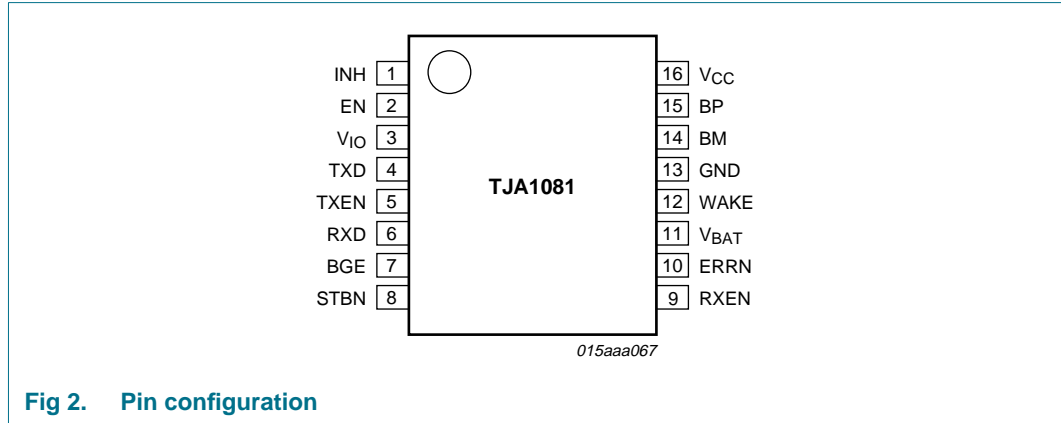

Fig 2. Pin configuration

5.2 Pin description

Table 2. Pin description

Symbol	Pin	Type	Description
INH	1	O	inhibit output for switching external voltage regulator
EN	2	I	enable input; enabled when HIGH; internal pull-down
V _{IO}	3	P	supply voltage for V _{IO} voltage level adaptation
TXD	4	I	transmit data input; internal pull-down
TXEN	5	I	transmitter enable input; when HIGH transmitter disabled; internal pull-up
RXD	6	O	receive data output
BGE	7	I	bus guardian enable input; when LOW transmitter disabled; internal pull-down
STBN	8	I	standby input; low-power mode when LOW; internal pull-down
RXEN	9	O	receive data enable output; when LOW bus activity detected
ERRN	10	O	error diagnoses output; when LOW error detected
V _{BAT}	11	P	battery supply voltage
WAKE	12	I	local wake-up input; internal pull-up or pull-down (depends on voltage at pin WAKE)
GND	13	P	ground
BM	14	I/O	bus line minus
BP	15	I/O	bus line plus
V _{CC}	16	P	supply voltage (+5 V)

6. Functional description

The block diagram of the transceiver is shown in [Figure 1](#).

6.1 Operating modes

The TJA1081 supports the following operating modes:

- Normal (normal-power mode)
- Receive-only (normal-power mode)
- Standby (low-power mode)
- Go-to-sleep (low-power mode)
- Sleep (low-power mode)

6.1.1 Bus activity and idle detection

The following mechanisms for activity and idle detection are valid in normal-power modes:

- If the absolute differential voltage on the bus lines is higher than $|V_{i(dif)det(act)}|$ for $t_{det(act)(bus)}$, activity is detected on the bus lines and pin RXEN is switched LOW which results in pin RXD being released:
 - If, after bus activity detection, the differential voltage on the bus lines is higher than $V_{IH(dif)}$, pin RXD will go HIGH
 - If, after bus activity detection, the differential voltage on the bus lines is lower than $V_{IL(dif)}$, pin RXD will go LOW
- If the absolute differential voltage on the bus lines is lower than $|V_{i(dif)det(act)}|$ for $t_{det(idle)(bus)}$, then idle is detected on the bus lines and pin RXEN is switched to HIGH. This results in pin RXD being blocked (pin RXD is switched to HIGH or stays HIGH)

6.2 Mode control pins: STBN and EN

Control inputs STBN and EN are used to select the operating mode. See [Table 3](#) for a detailed description of pin signalling and [Figure 3](#) for the timing diagram.

All mode transitions are controlled via the STBN and EN pins, unless an undervoltage condition is detected. If V_{IO} and (V_{CC} or V_{BAT}) are within their specified operating ranges, pin ERRN will indicate the status of the error flag.

Table 3. Pin signalling

Mode	STBN	EN	ERRN ^[1]		RXEN		RXD		Transmitter	INH
			LOW	HIGH	LOW	HIGH	LOW	HIGH		
Normal	HIGH	HIGH	error flag set	error flag reset	bus activity	bus idle	bus DATA_0	bus DATA_1 or idle	enabled	HIGH
Receive-only	HIGH	LOW							disabled	
Go-to-sleep	LOW	HIGH	error flag set ^[2]	error flag reset	wake flag set ^[2]	wake flag reset	wake flag set ^[2]	wake flag reset		
Standby	LOW	LOW								
Sleep	LOW	X								float

[1] Pin ERRN provides a serial interface for retrieving diagnostic information.

[2] Valid if V_{IO} and (V_{CC} or V_{BAT}) are present.

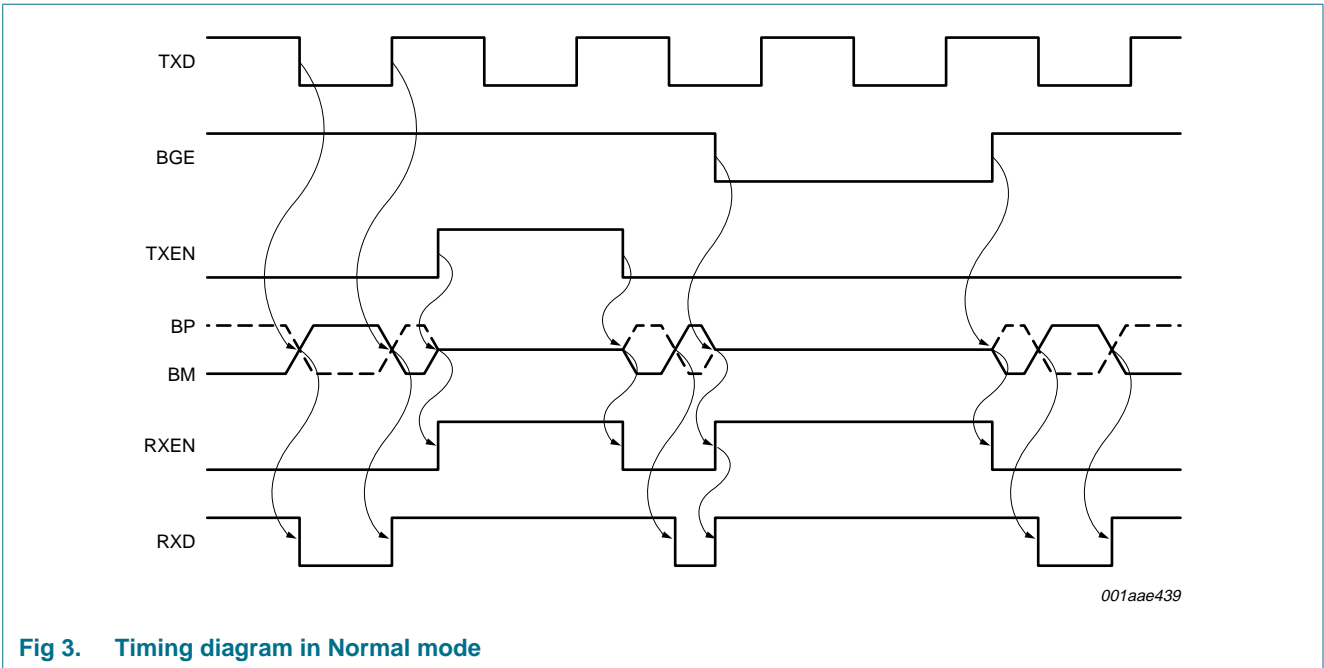

Fig 3. Timing diagram in Normal mode

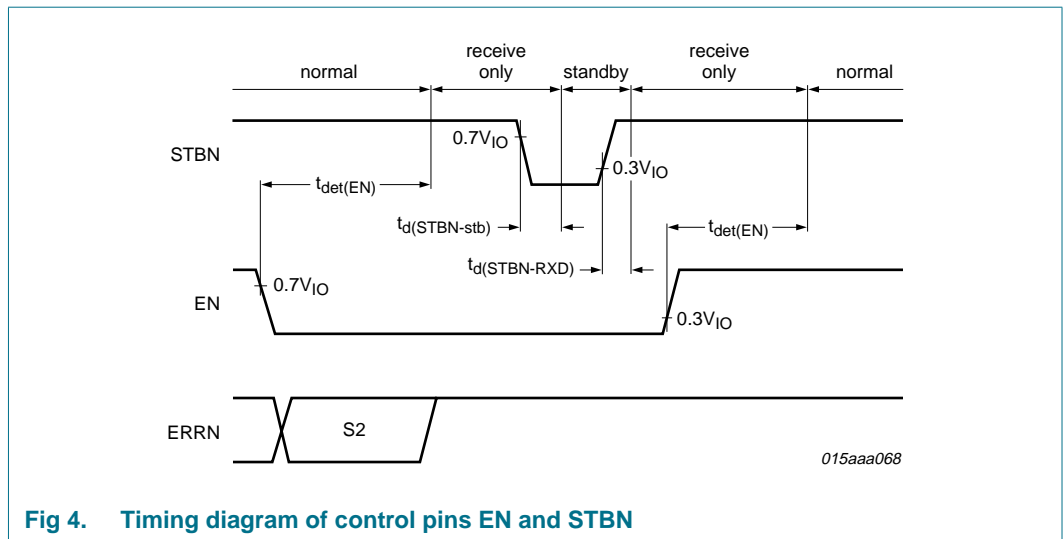
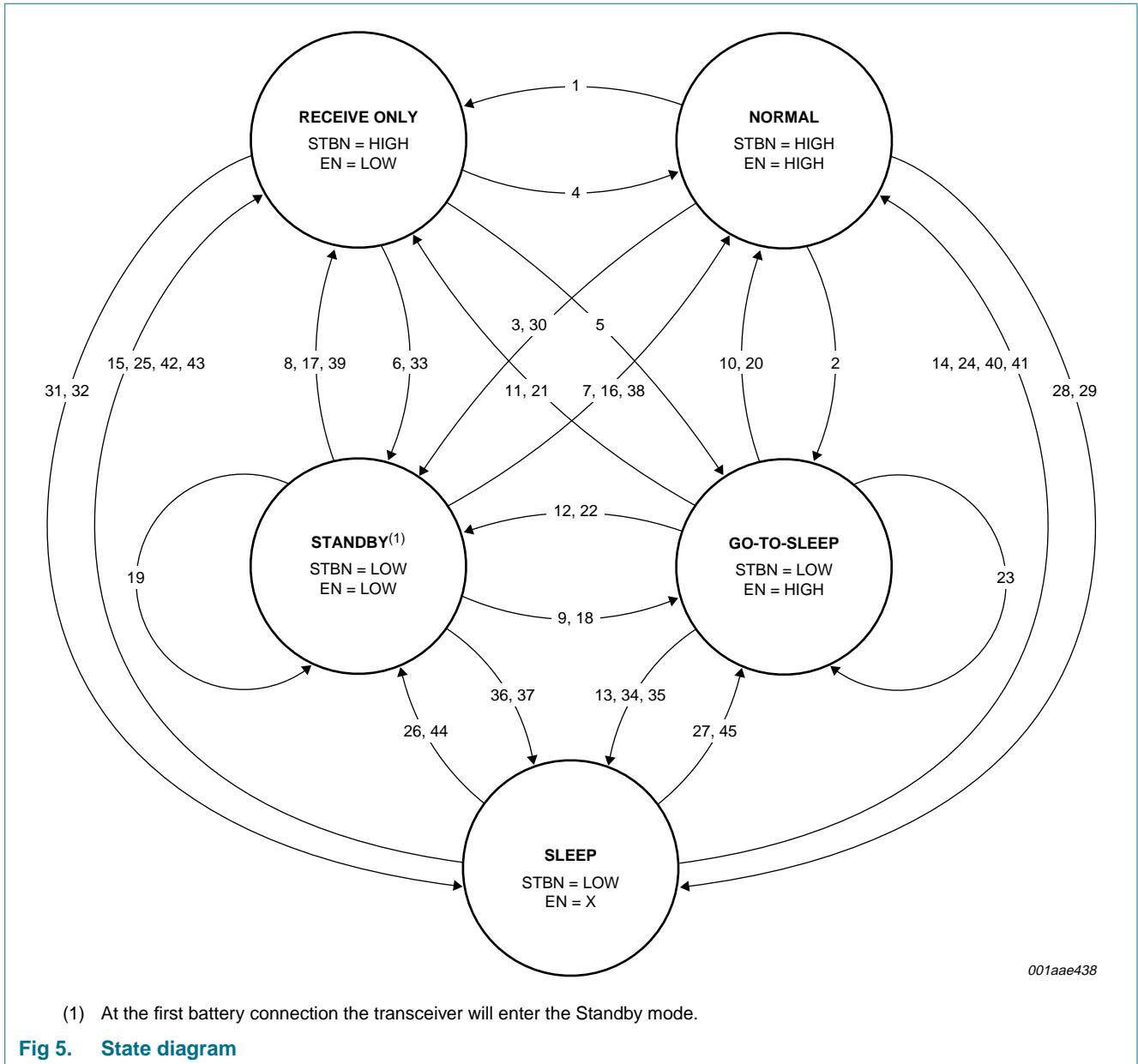

Fig 4. Timing diagram of control pins EN and STBN

The state diagram is shown in [Figure 5](#).



The state transitions are represented with numbers, which correspond with the numbers in column 3 of [Table 4](#) to [Table 7](#).

Table 4. State transitions forced by EN and STBN

→ indicates the action that initiates a transaction; 1→ and 2→ indicated the consequences of a transaction.

Transition from mode	Direction to mode	Transition number	Pin		Flag					Note
			STBN	EN	UV _{VIO}	UV _{VBAT}	UV _{VCC}	PWON	Wake	
Normal	Receive-only	1	H	→ L	cleared	cleared	cleared	cleared	cleared	
	Go-to-sleep	2	→ L	H	cleared	cleared	cleared	cleared	cleared	
	Standby	3	→ L	→ L	cleared	cleared	cleared	cleared	cleared	[1]
Receive-only	Normal	4	H	→ H	cleared	cleared	cleared	X	X	
	Go-to-sleep	5	→ L	→ H	cleared	cleared	cleared	X	X	
	Standby	6	→ L	L	cleared	cleared	cleared	X	X	
Standby	Normal	7	→ H	→ H	cleared	cleared	2 → cleared	X	1 → cleared	[2][3]
	Receive-only	8	→ H	L	cleared	cleared	2 → cleared	X	1 → set	[2][3]
	Go-to-sleep	9	L	→ H	cleared	cleared	X	X	X	
Go-to-sleep	Normal	10	→ H	H	cleared	cleared	cleared	X	1 → cleared	[2][4]
	Receive-only	11	→ H	→ L	cleared	cleared	cleared	X	1 → set	[2][4]
	Standby	12	L	→ L	cleared	cleared	X	X	X	[4]
	Sleep	13	L	H	cleared	cleared	X	X	cleared	[5]
Sleep	Normal	14	→ H	H	2 → cleared	2 → cleared	2 → cleared	X	1 → cleared	[2][3]
	Receive-only	15	→ H	L	2 → cleared	2 → cleared	2 → cleared	X	1 → set	[2][3]

[1] STBN must be set to LOW at least $t_{det(EN)}$ after the falling edge on EN.

[2] Positive edge on pin STBN sets the wake flag. In the case of a transition to Normal mode the wake flag is immediately cleared.

[3] Setting the wake flag clears the UV_{VIO}, UV_{VBAT} and UV_{VCC} flags.

[4] Hold time of go-to-sleep is less than $t_{h(gotosleep)}$.

[5] Hold time of go-to-sleep becomes greater than $t_{h(gotosleep)}$.

Table 5. State transitions forced by a wake-up

→ indicates the action that initiates a transaction; 1→ and 2→ indicated the consequences of a transaction.

Transition from mode	Direction to mode	Transition number	Pin		Flag					Note
			STBN	EN	UV _{VIO}	UV _{VBAT}	UV _{VCC}	PWON	Wake	
Standby	Normal	16	H	H	cleared	cleared	1 → cleared	X	→ set	[1]
	Receive-only	17	H	L	cleared	cleared	1 → cleared	X	→ set	[1]
	Go-to-sleep	18	L	H	cleared	cleared	1 → cleared	X	→ set	[1]
	Standby	19	L	L	cleared	cleared	1 → cleared	X	→ set	[1]
Go-to-sleep	Normal	20	H	H	cleared	cleared	1 → cleared	X	→ set	[1]
	Receive-only	21	H	L	cleared	cleared	1 → cleared	X	→ set	[1]
	Standby	22	L	L	cleared	cleared	1 → cleared	X	→ set	[1]
	Go-to-sleep	23	L	H	cleared	cleared	1 → cleared	X	→ set	[1]
Sleep	Normal	24	H	H	1 → cleared	1 → cleared	1 → cleared	X	→ set	[1][2]
	Receive-only	25	H	L	1 → cleared	1 → cleared	1 → cleared	X	→ set	[1][2]
	Standby	26	L	L	1 → cleared	1 → cleared	1 → cleared	X	→ set	[1]
	Go-to-sleep	27	L	H	1 → cleared	1 → cleared	1 → cleared	X	→ set	[1][2]

[1] Setting the wake flag clears the UV_{VIO}, UV_{VBAT} and UV_{VCC} flags.

[2] Transition via Standby mode.

Table 6. State transitions forced by an undervoltage condition

→ indicates the action that initiates a transaction; 1→ and 2→ indicated the consequences of a transaction.

Transition from mode	Direction to mode	Transition number	Flag					Note	
			UV _{VIO}	UV _{VBAT}	UV _{VCC}	PWON	Wake		
Normal	Sleep	28	→ set	cleared	cleared	cleared	cleared	cleared	[1]
	Sleep	29	cleared	→ set	cleared	cleared	cleared	cleared	[1]
	Standby	30	cleared	cleared	→ set	cleared	cleared	cleared	[1]
Receive-only	Sleep	31	→ set	cleared	cleared	X	X	1 → cleared	[1]
	Sleep	32	cleared	→ set	cleared	X	X	1 → cleared	[1]
	Standby	33	cleared	cleared	→ set	X	X	1 → cleared	[1]
Go-to-sleep	Sleep	34	→ set	cleared	cleared	X	X	1 → cleared	[1]
	Sleep	35	cleared	→ set	cleared	X	X	1 → cleared	[1]
Standby	Sleep	36	→ set	cleared	X	X	X	1 → cleared	[1][2]
	Sleep	37	cleared	→ set	X	X	X	1 → cleared	[1][3]

[1] UV_{VIO}, UV_{VBAT} or UV_{VCC} detected clears the wake flag.

[2] UV_{VIO} overrules UV_{VCC}.

[3] UV_{VBAT} overrules UV_{VCC}.

Table 7. State transitions forced by an undervoltage recovery
 → indicates the action that initiates a transaction; →1 and →2 are the consequences of a transaction.

Transition from mode	Direction to mode	Transition number	Pin		Flag					Note
			STBN	EN	UV _{VIO}	UV _{VBAT}	UV _{VCC}	PWON	Wake	
Standby	Normal	38	H	H	cleared	cleared	→ cleared	X	X	[1]
	Receive-only	39	H	L	cleared	cleared	→ cleared	X	X	[1]
Sleep	Normal	40	H	H	cleared	→ cleared	cleared	X	1 → cleared	[2][3]
	Normal	41	H	H	→ cleared	cleared	cleared	X	X	[4]
	Receive-only	42	H	L	cleared	→ cleared	cleared	X	1 → set	[2][3]
	Receive-only	43	H	L	→ cleared	cleared	cleared	X	X	[4]
	Standby	44	L	L	cleared	→ cleared	cleared	X	1 → set	[2][3]
	Sleep	45	L	X	→ cleared	cleared	cleared	X	cleared	[4]
	Go-to-sleep	46	L	H	cleared	→ cleared	cleared	X	1 → set	[2][3]
Sleep	47	L	X	→ cleared	cleared	cleared	X	cleared	[4]	

[1] Recovery of UV_{VCC} flag.

[2] Recovery of UV_{VBAT} flag.

[3] Clearing the UV_{VBAT} flag sets the wake flag. In the case of a transition to Normal mode the wake flag is immediately cleared.

[4] Recovery of UV_{VIO} flag.

6.2.1 Normal mode

In Normal mode the transceiver is able to transmit and receive data via the bus lines BP and BM. The output of the normal receiver is directly connected to pin RXD.

Transmitter behavior in Normal mode, with no time-out present on pins TXEN and BGE and the temperature flag not set (TEMP HIGH = 0; see [Table 9](#)), is detailed in [Table 8](#).

In this mode, pin INH is set HIGH.

Table 8. Transmitter function table

BGE	TXEN	TXD	Transmitter
L	X	X	transmitter is disabled
X	H	X	transmitter is disabled
H	L	H	transmitter is enabled; the bus lines are actively driven; BP is driven HIGH and BM is driven LOW
H	L	L	transmitter is enabled; the bus lines are actively driven; BP is driven LOW and BM is driven HIGH

6.2.2 Receive-only mode

In Receive-only mode the transceiver can only receive data. The transmitter is disabled, regardless of the voltage levels on pins BGE and TXEN.

In this mode, pin INH is set HIGH.

6.2.3 Standby mode

Standby mode is a low-power mode featuring very low current consumption. In this mode, the transceiver cannot transmit or receive data. The low-power receiver is activated to monitor the bus for wake-up patterns.

A transition to Standby mode can be triggered by applying the appropriate levels on pins EN and STBN (see [Figure 5](#) and [Table 4](#)) or if an undervoltage is detected on pin V_{CC} (see [Figure 5](#) and [Section 6.2.5](#)).

In this mode, pin INH is set HIGH.

If the wake flag is set, pins RXEN and RXD are driven LOW; otherwise pins RXEN and RXD are set HIGH (see [Section 6.3](#)).

6.2.4 Go-to-sleep mode

In this mode, the transceiver behaves as in Standby mode. If this mode is selected for a time longer than the go-to-sleep hold time ($t_{h(\text{gotosleep})}$) and the wake flag has been previously cleared, the transceiver will enter Sleep mode, regardless of the voltage on pin EN.

6.2.5 Sleep mode

Sleep mode is a low-power mode. The only difference between Sleep mode and Standby mode is that pin INH is set floating in Sleep mode. A transition to Sleep mode will be triggered from all other modes if the UV_{VIO} flag or the UV_{VBAT} flag is set (see [Table 6](#)).

If an undervoltage is detected on pin V_{CC} or V_{BAT} while V_{IO} is present, the wake flag is set by a positive edge on pin STBN, provided that V_{IO} and (V_{CC} or V_{BAT}) are present.

The undervoltage flags will be reset when the wake flag is set, and the transceiver will enter the mode indicated by the levels on pins EN and STBN if V_{IO} is present.

6.3 Wake-up mechanism

From Sleep mode (pin INH is switched off), the transceiver will enter Standby or Go-to-sleep mode (depending on the level at pin EN) if the wake flag is set. Consequently, pin INH is switched on.

If an undervoltage is not detected on pins V_{IO} , V_{CC} and V_{BAT} , the transceiver will switch immediately to the mode indicated by the levels on pins EN and STBN.

In Standby, Go-to-sleep and Sleep modes, pins RXD and RXEN are driven LOW if the wake flag is set.

6.3.1 Remote wake-up

6.3.1.1 Bus wake-up via wake-up pattern

Bus wake-up is detected if two consecutive DATA_0 of at least $t_{det(wake)DATA_0}$ separated by an idle or DATA_1 of at least $t_{det(wake)idle}$, followed by an idle or DATA_1 of at least $t_{det(wake)idle}$ are present on the bus lines within $t_{det(wake)tot}$.

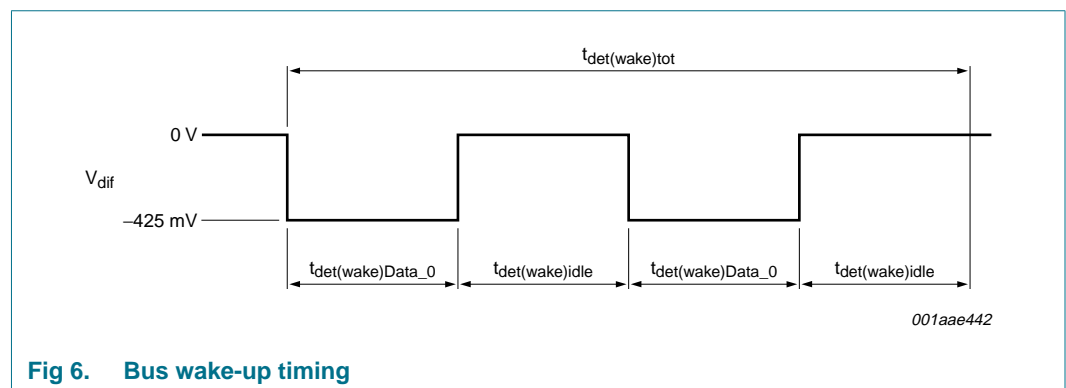

Fig 6. Bus wake-up timing

6.3.1.2 Bus wake-up via dedicated FlexRay data frame

The reception of a dedicated data frame, emulating a valid wake-up pattern, as shown in [Figure 7](#), sets the wake-up flag of the TJA1081.

Due to the Byte Start Sequence (BSS), preceding each byte, the DATA_0 and DATA_1 phases for the wake-up symbol are interrupted every 1 μ s. For 10 Mbit/s the maximum interruption time is 130 ns. Such interruptions do not prevent the transceiver from recognizing the wake-up pattern in the payload of a data frame.

The wake-up flag will not be set if an invalid wake-up pattern is received.

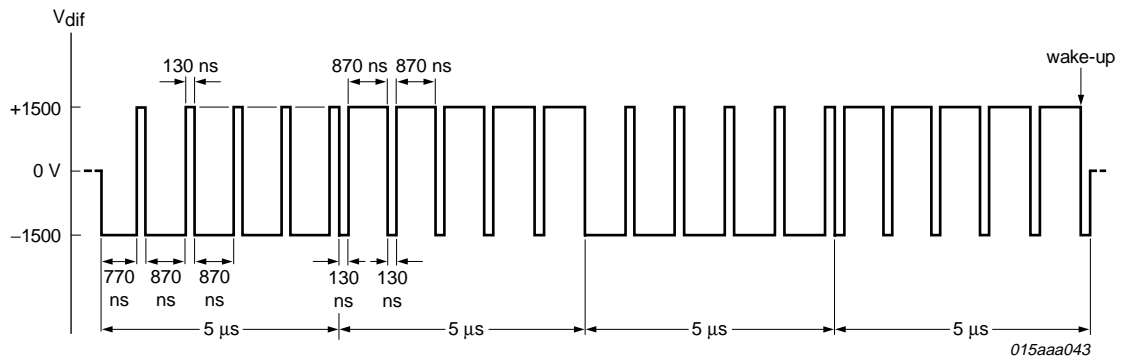

Each interruption is 130 ns.

The transition time from DATA_0 to DATA_1 and from DATA_1 to DATA_0 is about 20 ns.

The TJA1081 wake-up flag will be set with the following pattern:

```
FFh, FFh, FFh, FFh, FFh, 00h, 00h, 00h, 00h, 00h,
FFh, FFh, FFh, FFh, FFh, 00h, 00h, 00h, 00h, 00h,
FFh, FFh, FFh, FFh, FFh, 00h, 00h, 00h, 00h, 00h,
FFh, FFh, FFh, FFh, FFh, FFh
```

Fig 7. Minimum bus pattern for bus wake-up

6.3.2 Local wake-up via pin WAKE

If the voltage on pin WAKE is lower than $V_{th(det)(WAKE)}$ for longer than $t_{wake(WAKE)}$ (falling edge on pin WAKE) a local wake-up event on pin WAKE is detected. At the same time, the biasing of this pin is switched to pull-down.

If the voltage on pin WAKE is higher than $V_{th(det)(WAKE)}$ for longer than $t_{wake(WAKE)}$, the biasing of this pin is switched to pull-up, and no local wake-up will be detected.

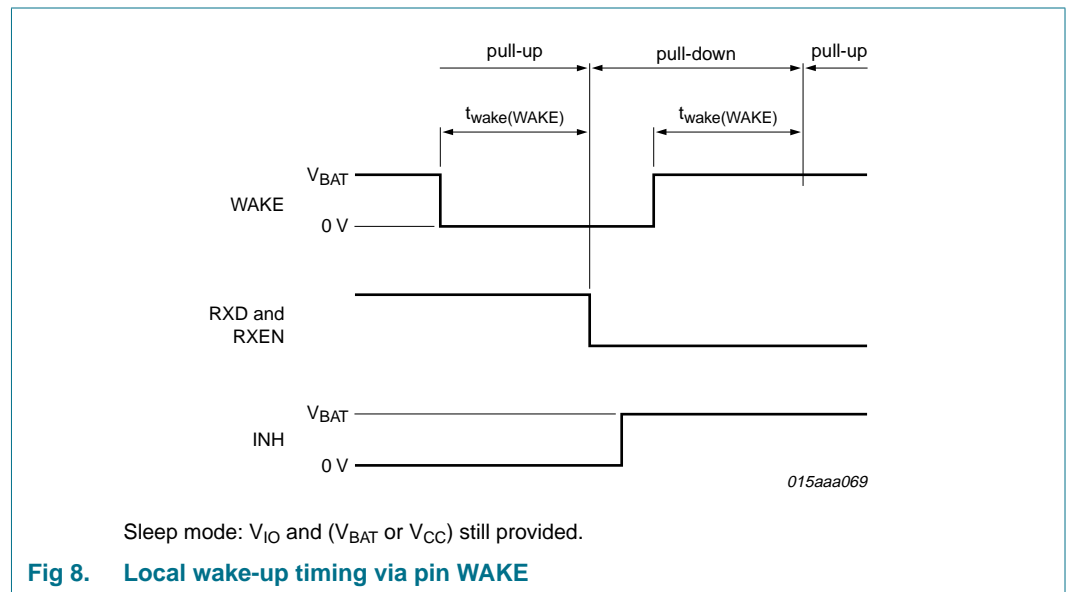

Sleep mode: V_{IO} and (V_{BAT} or V_{CC}) still provided.

Fig 8. Local wake-up timing via pin WAKE

6.4 Fail-silent behavior

In order to be fail silent, undervoltage detection and a reset mechanism for the digital state machine are implemented.

If an undervoltage is detected on pins V_{CC} , V_{IO} and/or V_{BAT} , the transceiver will enter a low-power mode. This ensures the passive and defined behavior of the transmitter and receiver when an undervoltage is detected.

In the range between the minimum operating voltage and the undervoltage detection threshold, the principle functions of the transmitter and receiver are maintained. However, in this range parameters (e.g. thresholds and delays of the transmitter and receiver) may deviate from the levels specified for the operating range.

The digital state machine is supplied by V_{CC} , V_{IO} or V_{BAT} , depending on which voltage is available. Therefore, the digital state machine will be properly supplied as long as the voltage on pin V_{CC} or pin V_{IO} remains above 4.75 V or the voltage on pin V_{BAT} remains above 6.5 V.

If the voltage on all pins (i.e. V_{CC} , V_{IO} and V_{BAT}) breaks down, a reset signal will be given to the digital state machine as soon as the internal supply voltage for the digital state machine becomes too low for the proper operation of the state machine. This ensures the passive and defined behavior of the digital state machine in the event of an overall supply voltage breakdown.

6.4.1 V_{BAT} undervoltage

If the $UV_{V_{BAT}}$ flag is set, the transceiver will enter Sleep mode (pin INH is switched off) regardless of the voltages present on pins EN and STBN. If the undervoltage recovers, the wake flag will be set and the transceiver will enter the mode determined by the voltages on pins EN and STBN.

6.4.2 V_{CC} undervoltage

If the $UV_{V_{CC}}$ flag is set, the transceiver will enter Standby mode regardless of the voltages present on pins EN and STBN. If the undervoltage recovers or the wake flag is set, mode switching via pins EN and STBN is possible.

6.4.3 V_{IO} undervoltage

If the voltage on pin V_{IO} is lower than $V_{uvd(V_{IO})}$ (even if the $UV_{V_{IO}}$ flag is reset) pins EN, STBN, TXD and BGE are set LOW (internally) and pin TXEN is set HIGH (internally). If the $UV_{V_{IO}}$ flag is set, the transceiver will enter Sleep mode (pin INH is switched off). If the undervoltage recovers or the wake flag is set, mode switching via pins EN and STBN is possible.

6.5 Flags

6.5.1 Local wake-up source flag

The local wake-up source flag can only be set in a low-power mode. When a wake-up event is detected on pin WAKE (see [Section 6.3.2](#)), the local wake-up source flag is set. The local wake-up source flag is reset by entering a low-power mode.

6.5.2 Remote wake-up source flag

The remote wake-up source flag can only be set in a low-power mode if pin V_{BAT} is within its operating range. When a remote wake-up event is detected on the bus lines (see [Section 6.3.1](#)), the remote wake-up source flag is set. The remote wake-up source flag is reset by entering a low-power mode.

6.5.3 Wake flag

The wake flag is set if one of the following events occurs:

- The local or remote wake-up source flag is set (edge sensitive)
- A positive edge is detected on pin STBN when V_{IO} is present
- Recovery of the UV_{VBAT} flag

The wake flag is reset by entering Normal mode, a low-power mode or by setting one of the undervoltage flags.

6.5.4 Power-on flag

The PWON power-on flag is set if the internal supply voltage for the digital part becomes higher than the lowest value it needs to operate. Entering Normal mode resets the PWON flag.

6.5.5 Temperature medium flag

The temperature medium flag is set if the junction temperature exceeds $T_{j(warn)(medium)}$ in a normal-power mode while pin V_{BAT} is within its operating range. The temperature medium flag is reset when the junction temperature drops below $T_{j(warn)(medium)}$ in a normal-power mode with pin V_{BAT} within its operating range or after a read of the status register in a low-power mode while pin V_{BAT} is within its operating range. No action will be taken if this flag is set.

6.5.6 Temperature high flag

The temperature high flag is set if the junction temperature exceeds $T_{j(dis)(high)}$ in a normal-power mode while pin V_{BAT} is within its operating range.

The temperature high flag is reset if a negative edge is applied to pin TXEN while the junction temperature is lower than $T_{j(dis)(high)}$ in a normal-power mode with pin V_{BAT} within its operating range.

If the temperature high flag is set, the transmitter will be disabled.

6.5.7 TXEN_BGE clamped flag

The TXEN_BGE clamped flag is set if pin TXEN is LOW and pin BGE is HIGH for longer than $t_{detCL(TXEN_BGE)}$. The TXEN_BGE clamped flag is reset if pin TXEN is HIGH or pin BGE is LOW. If the TXEN_BGE flag is set, the transmitter is disabled.

6.5.8 Bus error flag

The bus error flag is set if pin TXEN is LOW and pin BGE is HIGH and the data received from the bus lines (pins BP and BM) are different to that received on pin TXD. The transmission of any valid communication element, including a wake-up pattern, does not lead to bus error indication.

The error flag is reset if the data on the bus lines (pins BP and BM) are the same as on pin TXD or if the transmitter is disabled. No action will be taken if the bus error flag is set.

6.5.9 UV_{V_{BAT}} flag

The UV_{V_{BAT}} flag is set if the voltage on pin V_{BAT} is lower than V_{uvd(V_{BAT})}. The UV_{V_{BAT}} flag is reset if the voltage is higher than V_{uvd(V_{BAT})} or by setting the wake flag; see [Section 6.4.1](#).

6.5.10 UV_{V_{CC}} flag

The UV_{V_{CC}} flag is set if the voltage on pin V_{CC} is lower than V_{uvd(V_{CC})} for longer than t_{det(uv)(V_{CC})}. The flag is reset if the voltage on pin V_{CC} is higher than V_{uvd(V_{CC})} for longer than t_{rec(uv)(V_{CC})} or the wake flag is set; see [Section 6.4.2](#).

6.5.11 UV_{V_{IO}} flag

The UV_{V_{IO}} flag is set if the voltage on pin V_{IO} is lower than V_{uvd(V_{IO})} for longer than t_{det(uv)(V_{IO})}. The flag is reset if the voltage on pin V_{IO} is higher than V_{uvd(V_{IO})} or the wake flag is set; see [Section 6.4.3](#).

6.5.12 Error flag

The error flag is set if one of the status bits S4 to S10 is set. The error flag is reset if none of the S4 to S10 status bits are set; see [Table 9](#).

6.6 Status register

The status register can be read out on pin ERRN by using pin EN as clock; the status bits are given in [Table 9](#). The timing diagram is shown in [Figure 9](#).

The status register is accessible if:

- UV_{V_{IO}} flag is not set and the voltage on pin V_{IO} is between 4.75 V and 5.25 V
- UV_{V_{CC}} flag is not set and the voltage on pin V_{IO} is between 2.2 V and 4.75 V

After reading the status register, if no edge is detected on pin EN for longer than t_{det(EN)}, the status bits (S4 to S12) will be cleared if the corresponding flag has been reset. Pin ERRN is LOW if the corresponding status bit is set.

Table 9. Status bits

Bit number	Status bit	Description
S0	LOCAL WAKEUP	local wake-up source flag is redirected to this bit
S1	REMOTE WAKEUP	remote wake-up source flag is redirected to this bit
S2	-	not used; always set
S3	PWON	status bit set means PWON flag has been set previously
S4	BUS ERROR	status bit set means bus error flag has been set previously
S5	TEMP HIGH	status bit set means temperature high flag has been set previously
S6	TEMP MEDIUM	status bit set means temperature medium flag has been set previously
S7	TXEN_BGE CLAMPED	status bit set means TXEN_BGE clamped flag has been set previously
S8	UV _{V_{BAT}}	status bit set means UV _{V_{BAT}} flag has been set previously
S9	UV _{V_{CC}}	status bit set means UV _{V_{CC}} flag has been set previously

Table 9. Status bits ...continued

Bit number	Status bit	Description
S10	UVVIO	status bit set means UV _{VIO} flag has been set previously
S11	-	not used; always reset
S12	-	not used; always reset

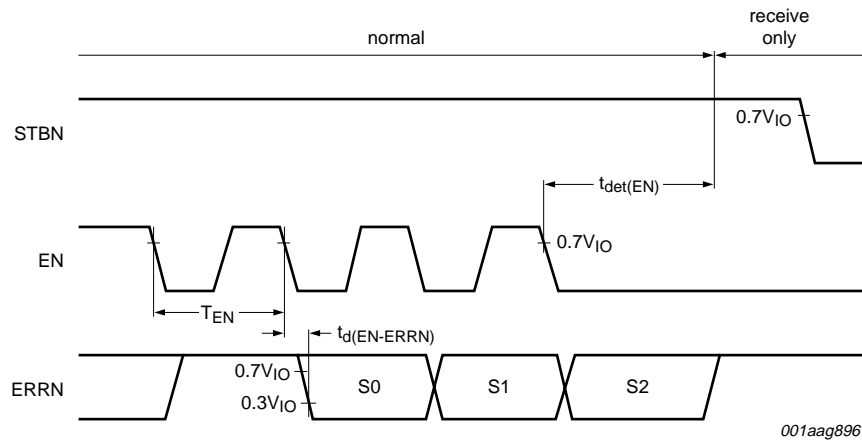

001aag896

Fig 9. Timing diagram for status bits

7. Limiting values

Table 10. Limiting values

In accordance with the Absolute Maximum Rating System (IEC 60134). All voltages are referenced to GND.

Symbol	Parameter	Conditions	Min	Max	Unit	
V _{BAT}	supply voltage on pin V _{BAT}	no time limit	-0.3	+60	V	
		operating range	6.5	60	V	
V _{CC}	supply voltage	no time limit	-0.3	+5.5	V	
		operating range	4.75	5.25	V	
V _{IO}	supply voltage on pin V _{IO}	no time limit	-0.3	+5.5	V	
		operating range	2.2	5.25	V	
V _{INH}	voltage on pin INH		-0.3	V _{BAT} + 0.3	V	
I _{O(INH)}	output current on pin INH	no time limit	-1	-	mA	
V _{WAKE}	voltage on pin WAKE		-0.3	V _{BAT} + 0.3	V	
I _{O(WAKE)}	output current on pin WAKE	pin GND not connected	-15	-	mA	
V _{BGE}	voltage on pin BGE	no time limit	-0.3	+5.5	V	
V _{TXEN}	voltage on pin TXEN	no time limit	-0.3	+5.5	V	
V _{TXD}	voltage on pin TXD	no time limit	-0.3	+5.5	V	
V _{ERRN}	voltage on pin ERRN	no time limit	-0.3	V _{IO} + 0.3	V	
V _{RXD}	voltage on pin RXD	no time limit	-0.3	V _{IO} + 0.3	V	
V _{RXEN}	voltage on pin RXEN	no time limit	-0.3	V _{IO} + 0.3	V	
V _{EN}	voltage on pin EN	no time limit	-0.3	+5.5	V	
V _{STBN}	voltage on pin STBN	no time limit	-0.3	+5.5	V	
V _{BP}	voltage on pin BP	no time limit	-60	+60	V	
V _{BM}	voltage on pin BM	no time limit	-60	+60	V	
V _{trt}	transient voltage	on pins BP and BM	[1]	-200	+200	V
		on pin V _{BAT}	[2]	-200	+200	V
		on pin V _{BAT}	[3]	6.5	60	V
		on pin V _{BAT}	[4]	-	60	V
T _{stg}	storage temperature		-55	+150	°C	
T _{vj}	virtual junction temperature		[5]	-40	+150	°C
V _{ESD}	electrostatic discharge voltage	HBM on pins BP and BM to ground	[6]	-8.0	+8.0	kV
		HBM at any other pin	[6]	-4.0	+4.0	kV
		MM on all pins	[7]	-200	+200	V
		CDM on all pins	[8]	-1000	+1000	V

[1] According to ISO 7637, part 3 test pulses a and b; Class C; see [Figure 13](#); R_{bus} = 45 Ω; C_{bus} = 100 pF.

[2] According to ISO 7637, part 2 test pulses 1, 2, 3a and 3b; Class C; see [Figure 13](#); R_{bus} = 45 Ω; C_{bus} = 100 pF.

[3] According to ISO 7637, part 2 test pulse 4; Class C; see [Figure 13](#); R_{bus} = 45 Ω; C_{bus} = 100 pF.

[4] According to ISO 7637, part 2 test pulse 5b; Class C; see [Figure 13](#); R_{bus} = 45 Ω; C_{bus} = 100 pF; V_{BAT} = 24 V.

[5] In accordance with IEC 60747-1. An alternative definition of T_{vj} is: T_{vj} = T_{amb} + P × R_{th(j-a)}, where R_{th(j-a)} is a fixed value to be used for the calculation of T_{vj}. The rating for T_{vj} limits the allowable combinations of power dissipation (P) and ambient temperature (T_{amb}).

[6] HBM: C = 100 pF; R = 1.5 kΩ.

[7] MM: C = 200 pF; L = 0.75 μH; R = 10 Ω.

[8] CDM: R = 1 Ω.

8. Thermal characteristics

Table 11. Thermal characteristics

Symbol	Parameter	Conditions	Typ	Unit
$R_{th(j-a)}$	thermal resistance from junction to ambient	in free air	118	K/W

9. Static characteristics

Table 12. Static characteristics

All parameters are guaranteed for $V_{BAT} = 6.5\text{ V to }60\text{ V}$; $V_{CC} = 4.75\text{ V to }5.25\text{ V}$; $V_{IO} = 2.2\text{ V to }5.25\text{ V}$; $T_{vj} = -40\text{ }^{\circ}\text{C to }+150\text{ }^{\circ}\text{C}$; $R_{bus} = 45\text{ }\Omega$ unless otherwise specified. All voltages are defined with respect to ground; positive currents flow into the IC.

Symbol	Parameter	Conditions	Min	Typ	Max	Unit
Pin V_{BAT}						
I_{BAT}	supply current on pin V_{BAT}	low-power modes; no load on pin INH	-	-	55	μA
		normal-power modes	-	-	1	mA
$V_{uvd(VBAT)}$	undervoltage detection voltage on pin V_{BAT}		2.75	-	4.5	V
Pin V_{CC}						
I_{CC}	supply current	low-power modes	-1	0	+10	μA
		Normal mode; $V_{BGE} = 0\text{ V}$; $V_{TXEN} = V_{IO}$; Receive-only mode	-	-	15	mA
		Normal mode; $V_{BGE} = V_{IO}$; $V_{TXEN} = 0\text{ V}$	-	-	37	mA
		Normal mode; $V_{BGE} = V_{IO}$; $V_{TXEN} = 0\text{ V}$; $R_{bus} = \infty\text{ }\Omega$	-	-	15	mA
$V_{uvd(VCC)}$	undervoltage detection voltage on pin V_{CC}	$V_{BAT} \geq 5.5\text{ V}$; $V_{IO} \geq 4.75\text{ V}$	2.75	-	4.5	V
Pin V_{IO}						
I_{IO}	supply current on pin V_{IO}	low-power modes	-1	+1	+10	μA
		Normal and Receive-only modes; $V_{TXD} = V_{IO}$	-	-	1000	μA
$V_{uvd(VIO)}$	undervoltage detection voltage on pin V_{IO}		1	-	2	V
$V_{uvr(VIO)}$	undervoltage recovery voltage on pin V_{IO}		1	-	2.2	V
$V_{uvhys(VIO)}$	undervoltage hysteresis voltage on pin V_{IO}	$V_{BAT} > 5.5\text{ V}$	25	-	200	mV
Pin EN						
$V_{IH(EN)}$	HIGH-level input voltage on pin EN		$0.7V_{IO}$	-	5.5	V
$V_{IL(EN)}$	LOW-level input voltage on pin EN		-0.3	-	$0.3V_{IO}$	V
$I_{IH(EN)}$	HIGH-level input current on pin EN	$V_{EN} = 0.7V_{IO}$	3	-	11	μA
$I_{IL(EN)}$	LOW-level input current on pin EN	$V_{EN} = 0\text{ V}$	-1	0	+1	μA
Pin STBN						
$V_{IH(STBN)}$	HIGH-level input voltage on pin STBN		$0.7V_{IO}$	-	5.5	V
$V_{IL(STBN)}$	LOW-level input voltage on pin STBN		-0.3	-	$0.3V_{IO}$	V
$I_{IH(STBN)}$	HIGH-level input current on pin STBN	$V_{STBN} = 0.7V_{IO}$	3	-	11	μA
$I_{IL(STBN)}$	LOW-level input current on pin STBN	$V_{STBN} = 0\text{ V}$	-1	0	+1	μA

Table 12. Static characteristics ...continued

All parameters are guaranteed for $V_{BAT} = 6.5\text{ V to }60\text{ V}$; $V_{CC} = 4.75\text{ V to }5.25\text{ V}$; $V_{IO} = 2.2\text{ V to }5.25\text{ V}$; $T_{vj} = -40\text{ }^{\circ}\text{C to }+150\text{ }^{\circ}\text{C}$; $R_{bus} = 45\ \Omega$ unless otherwise specified. All voltages are defined with respect to ground; positive currents flow into the IC.

Symbol	Parameter	Conditions	Min	Typ	Max	Unit
Pin TXEN						
$V_{IH(TXEN)}$	HIGH-level input voltage on pin TXEN		$0.7V_{IO}$	-	5.5	V
$V_{IL(TXEN)}$	LOW-level input voltage on pin TXEN		-0.3	-	$0.3V_{IO}$	V
$I_{IH(TXEN)}$	HIGH-level input current on pin TXEN	$V_{TXEN} = V_{IO}$	-1	0	+1	μA
$I_{IL(TXEN)}$	LOW-level input current on pin TXEN	$V_{TXEN} = 0.3V_{IO}$	-15	-	-3	μA
$I_{L(TXEN)}$	leakage current on pin TXEN	$V_{TXEN} = 5.25\text{ V}$; $V_{IO} = 0\text{ V}$	-1	0	+1	μA
Pin BGE						
$V_{IH(BGE)}$	HIGH-level input voltage on pin BGE		$0.7V_{IO}$	-	5.5	V
$V_{IL(BGE)}$	LOW-level input voltage on pin BGE		-0.3	-	$0.3V_{IO}$	V
$I_{IH(BGE)}$	HIGH-level input current on pin BGE	$V_{BGE} = 0.7V_{IO}$	3	-	11	μA
$I_{IL(BGE)}$	LOW-level input current on pin BGE	$V_{BGE} = 0\text{ V}$	-1	0	+1	μA
Pin TXD						
$V_{IH(TXD)}$	HIGH-level input voltage on pin TXD	normal-power modes	$0.7V_{IO}$	-	$V_{IO} + 0.3$	V
$V_{IL(TXD)}$	LOW-level input voltage on pin TXD	normal-power modes	-0.3	-	$0.3V_{IO}$	V
$I_{IH(TXD)}$	HIGH-level input current on pin TXD	$V_{TXD} = V_{IO}$	70	230	650	μA
$I_{IL(TXD)}$	LOW-level input current on pin TXD	normal-power modes; $V_{TXD} = 0\text{ V}$	-5	0	+5	μA
		low-power modes	-1	0	+1	μA
$I_{LI(TXD)}$	input leakage current on pin TXD	$V_{TXD} = 5.25\text{ V}$; $V_{IO} = 0\text{ V}$	-1	0	+1	μA
$C_i(TXD)$	input capacitance on pin TXD	not tested; with respect to [1] all other pins at ground; $V_{TXD} = 100\text{ mV}$; $f = 5\text{ MHz}$	-	5	10	pF
Pin RXD						
$I_{OH(RXD)}$	HIGH-level output current on pin RXD	$V_{RXD} = V_{IO} - 0.4\text{ V}$; $V_{IO} = V_{CC}$	-20	-	-2	mA
$I_{OL(RXD)}$	LOW-level output current on pin RXD	$V_{RXD} = 0.4\text{ V}$	2	-	20	mA
Pin ERRN						
$I_{OH(ERRN)}$	HIGH-level output current on pin ERRN	$V_{ERRN} = V_{IO} - 0.4\text{ V}$; $V_{IO} = V_{CC}$	-1500	-600	-100	μA
$I_{OL(ERRN)}$	LOW-level output current on pin ERRN	$V_{ERRN} = 0.4\text{ V}$	300	700	1500	μA
Pin RXEN						
$I_{OH(RXEN)}$	HIGH-level output current on pin RXEN	$V_{RXEN} = V_{IO} - 0.4\text{ V}$; $V_{IO} = V_{CC}$	-4	-1.7	-0.5	mA
$I_{OL(RXEN)}$	LOW-level output current on pin RXEN	$V_{RXEN} = 0.4\text{ V}$	1	3.2	8	mA
Pins BP and BM						
$V_{o(idle)(BP)}$	idle output voltage on pin BP	Normal or Receive-only mode; $V_{TXEN} = V_{IO}$	$0.4V_{CC}$	$0.5V_{CC}$	$0.6V_{CC}$	V
		Standby, Go-to-sleep or Sleep mode	-0.1	0	+0.1	V

Table 12. Static characteristics ...continued

All parameters are guaranteed for $V_{BAT} = 6.5\text{ V to }60\text{ V}$; $V_{CC} = 4.75\text{ V to }5.25\text{ V}$; $V_{IO} = 2.2\text{ V to }5.25\text{ V}$; $T_{vj} = -40\text{ }^{\circ}\text{C to }+150\text{ }^{\circ}\text{C}$; $R_{bus} = 45\text{ }\Omega$ unless otherwise specified. All voltages are defined with respect to ground; positive currents flow into the IC.

Symbol	Parameter	Conditions	Min	Typ	Max	Unit
$V_{o(idle)(BM)}$	idle output voltage on pin BM	Normal or Receive-only mode; $V_{TXEN} = V_{IO}$	$0.4V_{CC}$	$0.5V_{CC}$	$0.6V_{CC}$	V
		Standby, Go-to-sleep or Sleep mode	-0.1	0	+0.1	V
$I_{o(idle)BP}$	idle output current on pin BP	$-60\text{ V} \leq V_{BP} \leq +60\text{ V}$	-7.5	-	+7.5	mA
$I_{o(idle)BM}$	idle output current on pin BM	$-60\text{ V} \leq V_{BM} \leq +60\text{ V}$	-7.5	-	+7.5	mA
$V_{o(idle)(dif)}$	differential idle output voltage		-25	0	+25	mV
$V_{OH(dif)}$	differential HIGH-level output voltage	$40\text{ }\Omega \leq R_{bus} \leq 55\text{ }\Omega$; $V_{CC} = 5\text{ V}$; $C_{bus} = 100\text{ pF}$	600	850	1500	mV
$V_{OL(dif)}$	differential LOW-level output voltage	$40\text{ }\Omega \leq R_{bus} \leq 55\text{ }\Omega$; $V_{CC} = 5\text{ V}$; $C_{bus} = 100\text{ pF}$	-1500	-850	-600	mV
$V_{IH(dif)}$	differential HIGH-level input voltage	normal-power modes; $-10\text{ V} \leq V_{BP} \leq +15\text{ V}$; $-10\text{ V} \leq V_{BM} \leq +15\text{ V}$	150	210	300	mV
$V_{IL(dif)}$	differential LOW-level input voltage	normal-power modes; $-10\text{ V} \leq V_{BP} \leq +15\text{ V}$; $-10\text{ V} \leq V_{BM} \leq +15\text{ V}$	-300	-210	-150	mV
		low-power modes; $-10\text{ V} \leq V_{BP} \leq +15\text{ V}$; $-10\text{ V} \leq V_{BM} \leq +15\text{ V}$	-400	-210	-125	mV
$\Delta V_{i(dif)(H-L)}$	differential input voltage difference between HIGH-level and LOW-level	normal-power modes; $(V_{BP} + V_{BM}) / 2 = 2.5\text{ V}$	-	-	10	%
$ V_{i(dif)det(act)} $	activity detection differential input voltage (absolute value)	normal-power modes	150	210	300	mV
$ I_{O(sc)} $	short-circuit output current (absolute value)	on pin BP; $0\text{ V} \leq V_{BP} \leq 60\text{ V}$	-	-	35	mA
		on pin BM; $0\text{ V} \leq V_{BM} \leq 60\text{ V}$	-	-	35	mA
		on pins BP and BM; $V_{BP} = V_{BM}$; $0\text{ V} \leq V_{BP} \leq 60\text{ V}$; $0\text{ V} \leq V_{BM} \leq 60\text{ V}$	-	-	35	mA
$R_{i(BP)}$	input resistance on pin BP	idle level; $R_{bus} = \infty\text{ }\Omega$	10	18.5	40	k Ω
$R_{i(BM)}$	input resistance on pin BM	idle level; $R_{bus} = \infty\text{ }\Omega$	10	18.5	40	k Ω
$R_{i(dif)(BP-BM)}$	differential input resistance between pin BP and pin BM	idle level; $R_{bus} = \infty\text{ }\Omega$	20	37	80	k Ω
$I_{LI(BP)}$	input leakage current on pin BP	$V_{BP} = 5\text{ V}$; $V_{BAT} = V_{CC} = V_{IO} = 0\text{ V}$	-10	0	+10	μA
$I_{LI(BM)}$	input leakage current on pin BM	$V_{BM} = 5\text{ V}$; $V_{BAT} = V_{CC} = V_{IO} = 0\text{ V}$	-10	0	+10	μA
$V_{cm(bus)(DATA_0)}$	DATA_0 bus common-mode voltage	$R_{bus} = 45\text{ }\Omega$	$0.4V_{CC}$	$0.5V_{CC}$	$0.6V_{CC}$	V
$V_{cm(bus)(DATA_1)}$	DATA_1 bus common-mode voltage	$R_{bus} = 45\text{ }\Omega$	$0.4V_{CC}$	$0.5V_{CC}$	$0.6V_{CC}$	V
$\Delta V_{cm(bus)}$	bus common-mode voltage difference	$R_{bus} = 45\text{ }\Omega$	-25	0	+25	mV

Table 12. Static characteristics ...continued

All parameters are guaranteed for $V_{BAT} = 6.5\text{ V to }60\text{ V}$; $V_{CC} = 4.75\text{ V to }5.25\text{ V}$; $V_{IO} = 2.2\text{ V to }5.25\text{ V}$; $T_{vj} = -40\text{ }^{\circ}\text{C to }+150\text{ }^{\circ}\text{C}$; $R_{bus} = 45\text{ }\Omega$ unless otherwise specified. All voltages are defined with respect to ground; positive currents flow into the IC.

Symbol	Parameter	Conditions	Min	Typ	Max	Unit
$C_{i(BP)}$	input capacitance on pin BP	not tested; with respect to all other pins at ground; $V_{BP} = 100\text{ mV}$; $f = 5\text{ MHz}$	[1] -	8	15	pF
$C_{i(BM)}$	input capacitance on pin BM	not tested; with respect to all other pins at ground; $V_{BM} = 100\text{ mV}$; $f = 5\text{ MHz}$	[1] -	8	15	pF
$C_{i(dif)(BP-BM)}$	differential input capacitance between pin BP and pin BM	not tested; with respect to all other pins at ground; $V_{(BM-BP)} = 100\text{ mV}$; $f = 5\text{ MHz}$	[1] -	2	5	pF

Pin INH

$V_{OH(INH)}$	HIGH-level output voltage on pin INH	$I_{INH} = -0.2\text{ mA}$	$V_{BAT} - 0.8$	$V_{BAT} - 0.3$	$V_{BAT} - 0.1$	V
$I_{L(INH)}$	leakage current on pin INH	Sleep mode	-5	0	+5	μA
$I_{OL(INH)}$	LOW-level output current on pin INH	$V_{INH} = 0\text{ V}$	-15	-5	-1	mA

Pin WAKE

$V_{th(det)(WAKE)}$	detection threshold voltage on pin WAKE	low-power mode	2.5	-	4.5	V
$I_{IL(WAKE)}$	LOW-level input current on pin WAKE	$V_{WAKE} = 2.4\text{ V}$ for $t > t_{wake(WAKE)}$	3	-	11	μA
$I_{IH(WAKE)}$	HIGH-level input current on pin WAKE	$V_{WAKE} = 4.6\text{ V}$ for $t > t_{wake(WAKE)}$	-11	-	-3	μA

Temperature protection

$T_{j(warn)(medium)}$	medium warning junction temperature	$V_{BAT} > 5.5\text{ V}$	155	165	175	$^{\circ}\text{C}$
$T_{j(dis)(high)}$	high disable junction temperature	$V_{BAT} > 5.5\text{ V}$	180	190	200	$^{\circ}\text{C}$

Power-on reset

$V_{th(det)POR}$	power-on reset detection threshold voltage		3.0	-	3.4	V
$V_{th(rec)POR}$	power-on reset recovery threshold voltage		3.1	-	3.5	V
$V_{hys(POR)}$	power-on reset hysteresis voltage		100	-	200	mV

[1] These values are based on measurements taken on several samples (less than 10 pieces). These measurements have taken place in the laboratory and have been done at $T_{amb} = 25\text{ }^{\circ}\text{C}$ and $T_{amb} = 125\text{ }^{\circ}\text{C}$. No characterization has been done for these parameters. No industrial test will be performed on production products.

10. Dynamic characteristics

Table 13. Dynamic characteristics

All parameters are guaranteed for $V_{BAT} = 6.5\text{ V to }60\text{ V}$; $V_{CC} = 4.75\text{ V to }5.25\text{ V}$; $V_{IO} = 2.2\text{ V to }5.25\text{ V}$; $T_{vj} = -40\text{ }^{\circ}\text{C to }+150\text{ }^{\circ}\text{C}$; $R_{bus} = 45\text{ }\Omega$ unless otherwise specified. All voltages are defined with respect to ground; positive currents flow into the IC.

Symbol	Parameter	Conditions	Min	Typ	Max	Unit
Pins BP and BM						
$t_{d(TXD-bus)}$	delay time from TXD to bus	Normal mode	[1]			
		DATA_0	-	-	50	ns
		DATA_1	-	-	50	ns
$\Delta t_{d(TXD-bus)}$	delay time difference from TXD to bus	Normal mode; between DATA_0 and DATA_1	[1]	-	4	ns
$t_{d(bus-RXD)}$	delay time from bus to RXD	Normal mode; $C_{RXD} = 15\text{ pF}$; see Figure 11				
		DATA_0	-	-	50	ns
		DATA_1	-	-	50	ns
$\Delta t_{d(bus-RXD)}$	delay time difference from bus to RXD	Normal mode $C_{RXD} = 15\text{ pF}$; between DATA_0 and DATA_1; see Figure 11	-	-	5	ns
$t_{d(TXEN-busidle)}$	delay time from TXEN to bus idle	Normal mode	-	-	80	ns
$t_{d(TXEN-busact)}$	delay time from TXEN to bus active	Normal mode	-	-	75	ns
$t_{d(BGE-busidle)}$	delay time from BGE to bus idle	Normal mode	-	-	100	ns
$t_{d(BGE-busact)}$	delay time from BGE to bus active	Normal mode	-	-	75	ns
$t_{d(bus)(idle-act)}$	bus delay time from idle to active	Normal mode	-	-	30	ns
$t_{d(bus)(act-idle)}$	bus delay time from active to idle	Normal mode	-	-	30	ns
$t_{r(dif)(bus)}$	bus differential rise time	10 % to 90 %; $R_{bus} = 45\text{ }\Omega$; $C_{bus} = 100\text{ pF}$	5	17	25	ns
$t_{f(dif)(bus)}$	bus differential fall time	90 % to 10 %; $R_{bus} = 45\text{ }\Omega$; $C_{bus} = 100\text{ pF}$	5	17	25	ns
WAKE symbol detection						
$t_{det(wake)DATA_0}$	DATA_0 wake-up detection time	Standby or Sleep mode; $-10\text{ V} \leq V_{BP} \leq +15\text{ V}$; $-10\text{ V} \leq V_{BM} \leq +15\text{ V}$	1	-	4	μs
$t_{det(wake)idle}$	idle wake-up detection time		1	-	4	μs
$t_{det(wake)tot}$	total wake-up detection time		50	-	115	μs
Undervoltage						
$t_{det(uv)(VCC)}$	undervoltage detection time on pin V_{CC}		100	-	670	ms
$t_{rec(uv)(VCC)}$	undervoltage recovery time on pin V_{CC}		1	-	5.2	ms
$t_{det(uv)(VIO)}$	undervoltage detection time on pin V_{IO}		100	-	670	ms
$t_{det(uv)(VBAT)}$	undervoltage detection time on pin V_{BAT}		-	-	1	ms
Activity detection						
$t_{det(act)(bus)}$	activity detection time on bus pins	V_{dif} : 0 mV \rightarrow 400 mV	100	-	250	ns
$t_{det(idle)(bus)}$	idle detection time on bus pins	V_{dif} : 400 mV \rightarrow 0 mV	100	-	245	ns
Mode control pins						
$t_{d(STBN-RXD)}$	STBN to RXD delay time	STBN HIGH to RXD HIGH; wake flag set	-	-	2	μs

Table 13. Dynamic characteristics ...continued

All parameters are guaranteed for $V_{BAT} = 6.5\text{ V to }60\text{ V}$; $V_{CC} = 4.75\text{ V to }5.25\text{ V}$; $V_{IO} = 2.2\text{ V to }5.25\text{ V}$; $T_{vj} = -40^\circ\text{C to }+150^\circ\text{C}$; $R_{bus} = 45\ \Omega$ unless otherwise specified. All voltages are defined with respect to ground; positive currents flow into the IC.

Symbol	Parameter	Conditions	Min	Typ	Max	Unit
$t_{d(STBN-stb)}$	delay time from STBN to standby mode	STBN LOW to Standby mode; Receive-only mode ^[2]	-	-	10	μs
$t_{h(gotosleep)}$	go-to-sleep hold time		20	35	50	μs
Status register						
$t_{det(EN)}$	detection time on pin EN	for mode control	20	-	80	μs
T_{EN}	time period on pin EN	for reading status bits	4	-	20	μs
$t_{d(EN-ERRN)}$	delay time from EN to ERRN	for reading status bits	-	-	2	μs
WAKE						
$t_{wake(WAKE)}$	wake-up time on pin WAKE	low-power modes; falling edge on pin WAKE; $6.5\text{ V} \leq V_{BAT} \leq 27\text{ V}$	5	28	100	μs
		low-power modes; falling edge on pin WAKE; $27\text{ V} < V_{BAT} \leq 60\text{ V}$	25	75	175	μs
Miscellaneous						
$t_{detCL(TXEN_BGE)}$	TXEN_BGE clamp detection time		2600	-	10400	μs

[1] Rise and fall time (10 % to 90 %) of $t_{r(TXD)}$ and $t_{f(TXD)} = 5\text{ ns} \pm 1\text{ ns}$.

[2] Same parameter is guaranteed by design for the transition from Normal to Go-to-sleep mode.

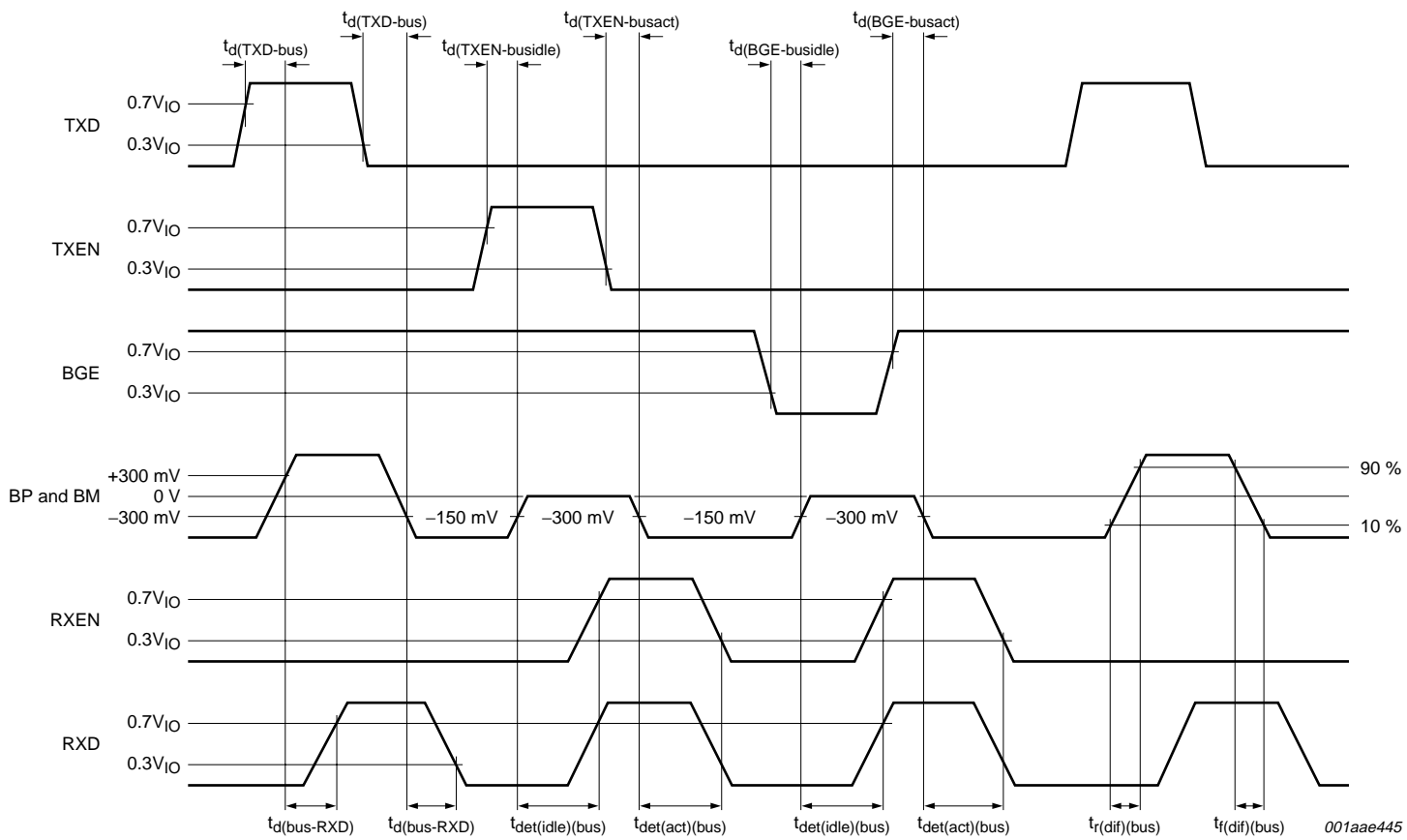
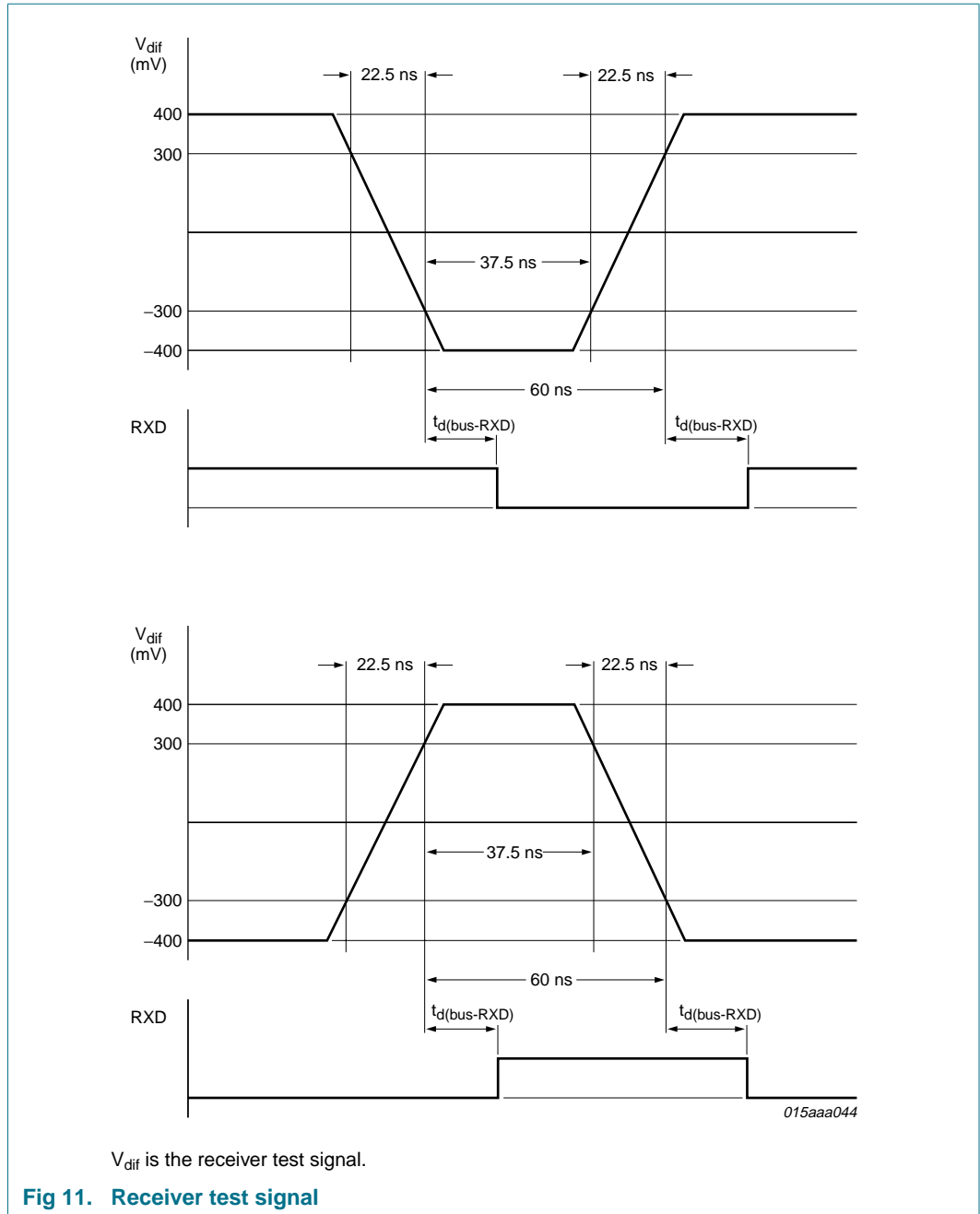

Fig 10. Detailed timing diagram



11. Test information

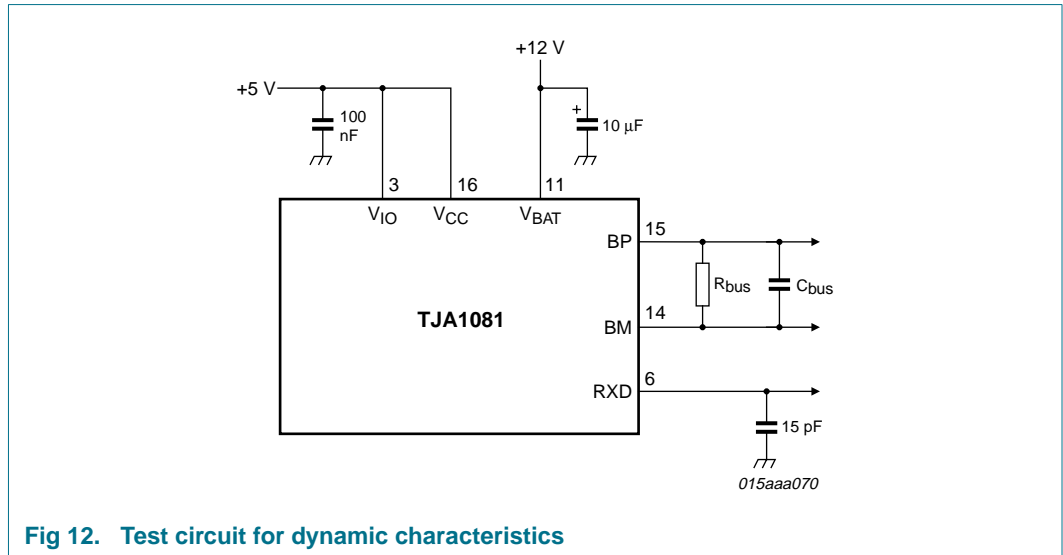

Fig 12. Test circuit for dynamic characteristics

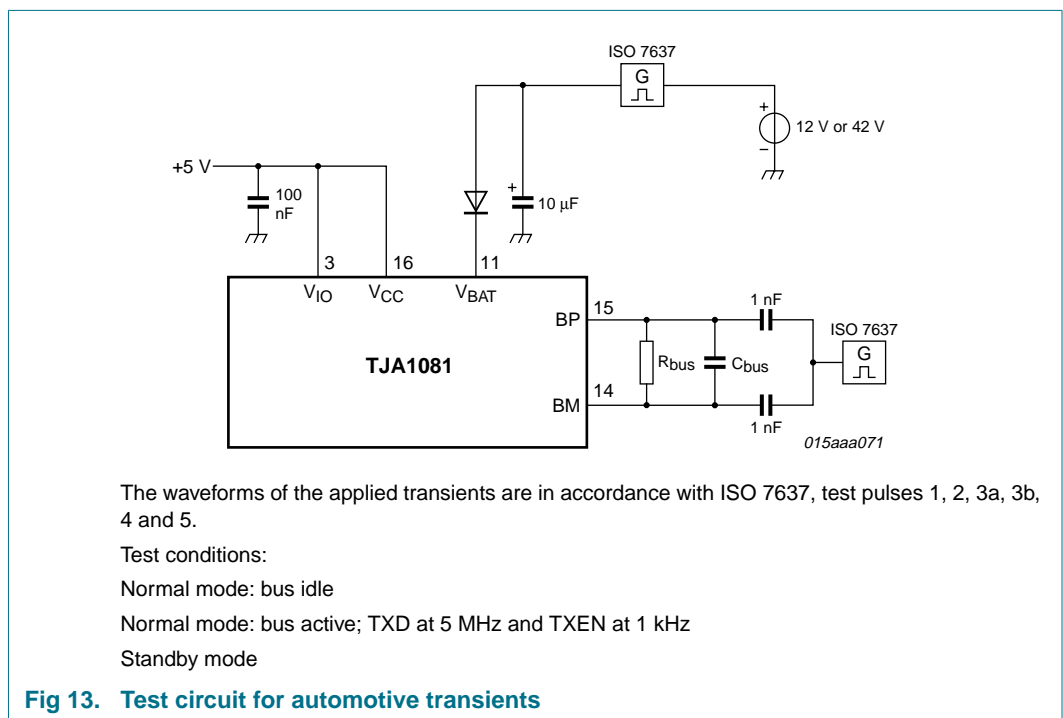

Fig 13. Test circuit for automotive transients

12. Package outline

SSOP16: plastic shrink small outline package; 16 leads; body width 5.3 mm

SOT338-1

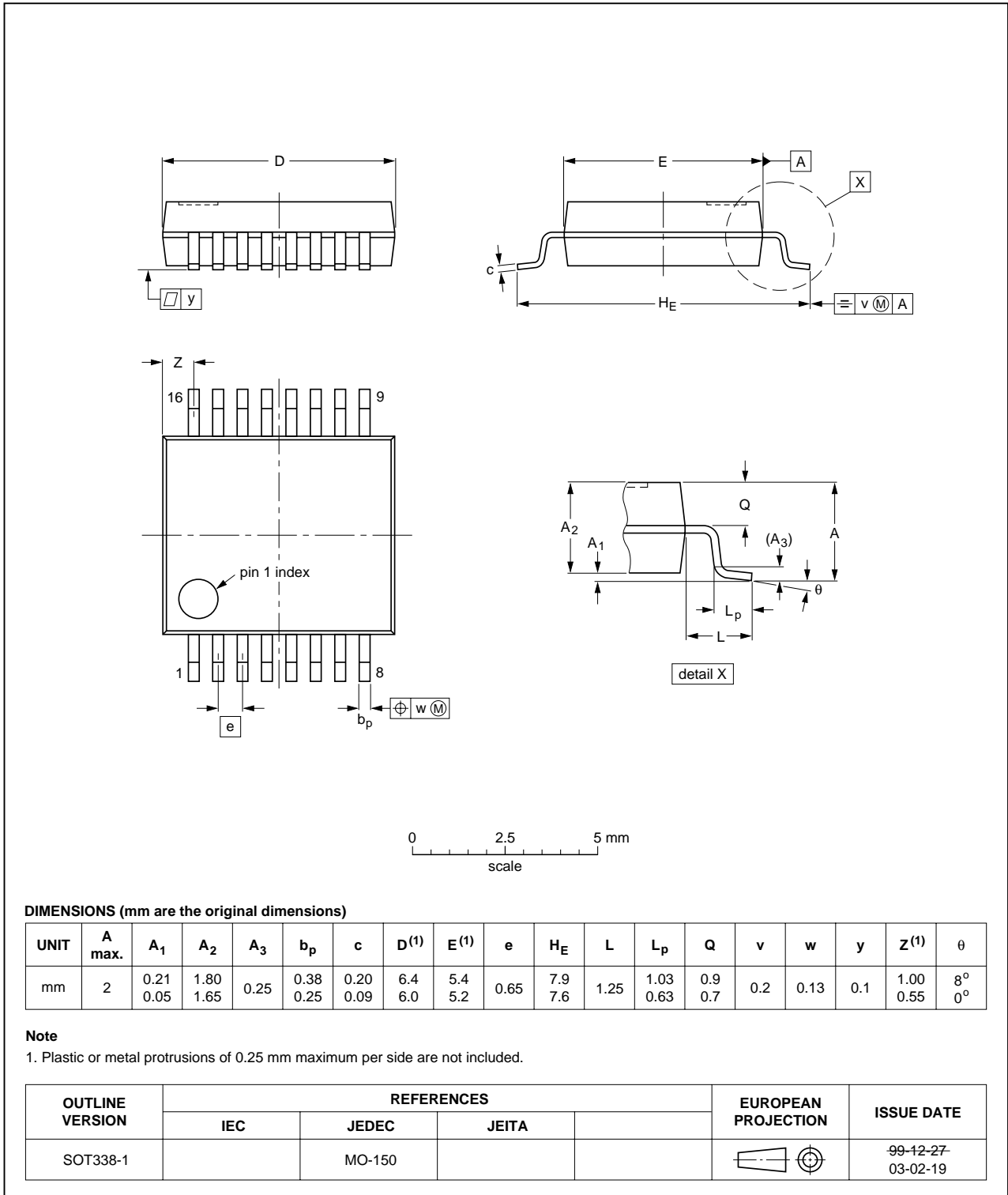

Fig 14. Package outline SOT338-1 (SSOP16)

13. Soldering of SMD packages

This text provides a very brief insight into a complex technology. A more in-depth account of soldering ICs can be found in Application Note *AN10365 "Surface mount reflow soldering description"*.

13.1 Introduction to soldering

Soldering is one of the most common methods through which packages are attached to Printed Circuit Boards (PCBs), to form electrical circuits. The soldered joint provides both the mechanical and the electrical connection. There is no single soldering method that is ideal for all IC packages. Wave soldering is often preferred when through-hole and Surface Mount Devices (SMDs) are mixed on one printed wiring board; however, it is not suitable for fine pitch SMDs. Reflow soldering is ideal for the small pitches and high densities that come with increased miniaturization.

13.2 Wave and reflow soldering

Wave soldering is a joining technology in which the joints are made by solder coming from a standing wave of liquid solder. The wave soldering process is suitable for the following:

- Through-hole components
- Leaded or leadless SMDs, which are glued to the surface of the printed circuit board

Not all SMDs can be wave soldered. Packages with solder balls, and some leadless packages which have solder lands underneath the body, cannot be wave soldered. Also, leaded SMDs with leads having a pitch smaller than ~0.6 mm cannot be wave soldered, due to an increased probability of bridging.

The reflow soldering process involves applying solder paste to a board, followed by component placement and exposure to a temperature profile. Leaded packages, packages with solder balls, and leadless packages are all reflow solderable.

Key characteristics in both wave and reflow soldering are:

- Board specifications, including the board finish, solder masks and vias
- Package footprints, including solder thieves and orientation
- The moisture sensitivity level of the packages
- Package placement
- Inspection and repair
- Lead-free soldering versus SnPb soldering

13.3 Wave soldering

Key characteristics in wave soldering are:

- Process issues, such as application of adhesive and flux, clinching of leads, board transport, the solder wave parameters, and the time during which components are exposed to the wave
- Solder bath specifications, including temperature and impurities

13.4 Reflow soldering

Key characteristics in reflow soldering are:

- Lead-free versus SnPb soldering; note that a lead-free reflow process usually leads to higher minimum peak temperatures (see [Figure 15](#)) than a SnPb process, thus reducing the process window
- Solder paste printing issues including smearing, release, and adjusting the process window for a mix of large and small components on one board
- Reflow temperature profile; this profile includes preheat, reflow (in which the board is heated to the peak temperature) and cooling down. It is imperative that the peak temperature is high enough for the solder to make reliable solder joints (a solder paste characteristic). In addition, the peak temperature must be low enough that the packages and/or boards are not damaged. The peak temperature of the package depends on package thickness and volume and is classified in accordance with [Table 14](#) and [15](#)

Table 14. SnPb eutectic process (from J-STD-020C)

Package thickness (mm)	Package reflow temperature (°C)	
	Volume (mm ³)	
	< 350	≥ 350
< 2.5	235	220
≥ 2.5	220	220

Table 15. Lead-free process (from J-STD-020C)

Package thickness (mm)	Package reflow temperature (°C)		
	Volume (mm ³)		
	< 350	350 to 2000	> 2000
< 1.6	260	260	260
1.6 to 2.5	260	250	245
> 2.5	250	245	245

Moisture sensitivity precautions, as indicated on the packing, must be respected at all times.

Studies have shown that small packages reach higher temperatures during reflow soldering, see [Figure 15](#).

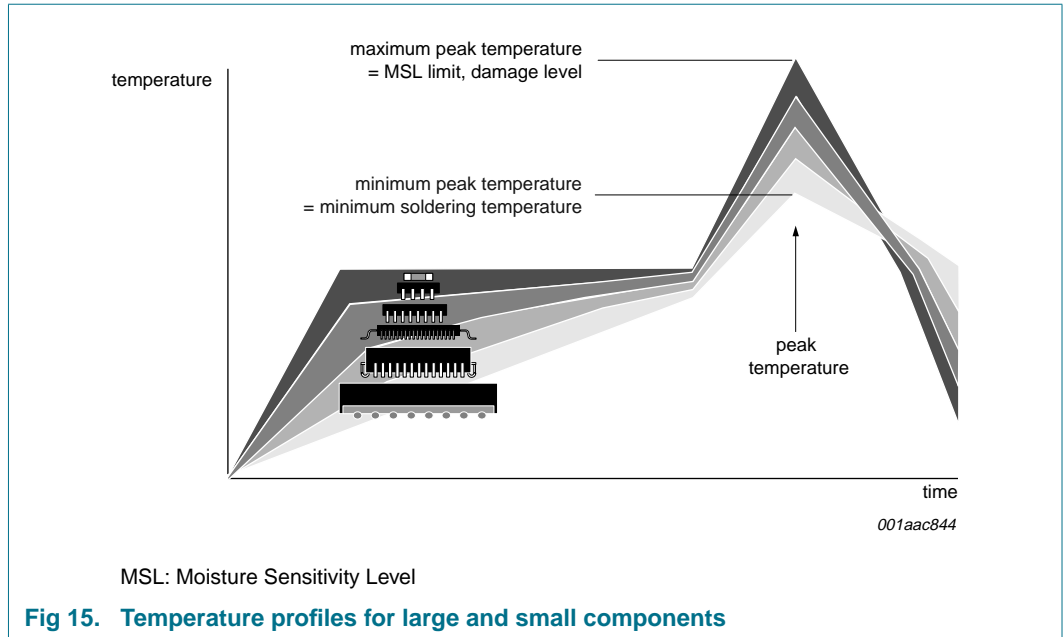

For further information on temperature profiles, refer to Application Note AN10365 “Surface mount reflow soldering description”.

14. Abbreviations

Table 16. Abbreviations

Abbreviation	Description
BSS	Byte Start Sequence
CDM	Charged Device Model
ECU	Electronic Control Unit
EMC	ElectroMagnetic Compatibility
EME	ElectroMagnetic Emission
EMI	ElectroMagnetic Immunity
ESD	ElectroStatic Discharge
HBM	Human Body Model
MM	Machine Model
TSS	Transmission Start Sequence

15. References

- [1] EPL — FlexRay Communications System Electrical Physical Layer Specification Version 2.1 Rev. A, FlexRay Consortium, Dec. 2005
- [2] TJA1080A — FlexRay transceiver data sheet, www.nxp.com

16. Revision history

Table 17. Revision history

Document ID	Release date	Data sheet status	Change notice	Supersedes
TJA1081_3	20090904	Product data sheet	-	TJA1081_2
Modifications:		<ul style="list-style-type: none">• Table 12 “Static characteristics”, parameter V_{IO} added to the conditions for $V_{uvd}(V_{CC})$• Table 12 “Static characteristics”, parameters $I_{O(sc)(BP)}$ and $I_{O(sc)(BM)}$ changed to $I_{O(sc)}$		
TJA1081_2	20090728	Product data sheet	-	TJA1081_1
TJA1081_1	20090415	Preliminary data sheet	-	-

17. Legal information

17.1 Data sheet status

Document status ^{[1][2]}	Product status ^[3]	Definition
Objective [short] data sheet	Development	This document contains data from the objective specification for product development.
Preliminary [short] data sheet	Qualification	This document contains data from the preliminary specification.
Product [short] data sheet	Production	This document contains the product specification.

[1] Please consult the most recently issued document before initiating or completing a design.

[2] The term 'short data sheet' is explained in section "Definitions".

[3] The product status of device(s) described in this document may have changed since this document was published and may differ in case of multiple devices. The latest product status information is available on the Internet at URL <http://www.nxp.com>.

17.2 Definitions

Draft — The document is a draft version only. The content is still under internal review and subject to formal approval, which may result in modifications or additions. NXP Semiconductors does not give any representations or warranties as to the accuracy or completeness of information included herein and shall have no liability for the consequences of use of such information.

Short data sheet — A short data sheet is an extract from a full data sheet with the same product type number(s) and title. A short data sheet is intended for quick reference only and should not be relied upon to contain detailed and full information. For detailed and full information see the relevant full data sheet, which is available on request via the local NXP Semiconductors sales office. In case of any inconsistency or conflict with the short data sheet, the full data sheet shall prevail.

17.3 Disclaimers

General — Information in this document is believed to be accurate and reliable. However, NXP Semiconductors does not give any representations or warranties, expressed or implied, as to the accuracy or completeness of such information and shall have no liability for the consequences of use of such information.

Right to make changes — NXP Semiconductors reserves the right to make changes to information published in this document, including without limitation specifications and product descriptions, at any time and without notice. This document supersedes and replaces all information supplied prior to the publication hereof.

Suitability for use in automotive applications only — This NXP Semiconductors product has been developed for use in automotive applications only. The product is not designed, authorized or warranted to be suitable for any other use, including medical, military, aircraft, space or life support equipment, nor in applications where failure or malfunction of an NXP Semiconductors product can reasonably be expected to result in personal injury, death or severe property or environmental damage. NXP Semiconductors accepts no liability for inclusion and/or use of NXP Semiconductors products in such equipment or applications and therefore such inclusion and/or use is at the customers own risk.

Applications — Applications that are described herein for any of these products are for illustrative purposes only. NXP Semiconductors makes no representation or warranty that such applications will be suitable for the specified use without further testing or modification.

Limiting values — Stress above one or more limiting values (as defined in the Absolute Maximum Ratings System of IEC 60134) may cause permanent damage to the device. Limiting values are stress ratings only and operation of the device at these or any other conditions above those given in the Characteristics sections of this document is not implied. Exposure to limiting values for extended periods may affect device reliability.

Terms and conditions of sale — NXP Semiconductors products are sold subject to the general terms and conditions of commercial sale, as published at <http://www.nxp.com/profile/terms>, including those pertaining to warranty, intellectual property rights infringement and limitation of liability, unless explicitly otherwise agreed to in writing by NXP Semiconductors. In case of any inconsistency or conflict between information in this document and such terms and conditions, the latter will prevail.

No offer to sell or license — Nothing in this document may be interpreted or construed as an offer to sell products that is open for acceptance or the grant, conveyance or implication of any license under any copyrights, patents or other industrial or intellectual property rights.

Export control — This document as well as the item(s) described herein may be subject to export control regulations. Export might require a prior authorization from national authorities.

17.4 Licenses

Purchase of NXP ICs with FlexRay functionality

FlexRay license required. This product has been developed within the framework of the "FlexRay" consortium. FlexRay consortium members are willing to grant licenses under their essential FlexRay intellectual property rights to end users of FlexRay-enabled products upon request of an end user. The sale by NXP Semiconductors of a FlexRay-enabled product will not be construed as the granting of such a license. Each end user will have to apply to the FlexRay consortium administration to obtain such a license or to apply for membership. The FlexRay consortium can be contacted at request@flexray.com.

17.5 Trademarks

Notice: All referenced brands, product names, service names and trademarks are the property of their respective owners.

18. Contact information

For more information, please visit: <http://www.nxp.com>

For sales office addresses, please send an email to: salesaddresses@nxp.com

19. Contents

1	General description	1	6.6	Status register	17
2	Features	1	7	Limiting values	19
2.1	Optimized for time triggered communication systems.	1	8	Thermal characteristics	20
2.2	Low power management	1	9	Static characteristics	20
2.3	Diagnosis (detection and signalling)	2	10	Dynamic characteristics	24
2.4	Protections	2	11	Test information	28
2.5	Functional classes according to FlexRay electrical physical layer specification (see Ref. 1)	2	12	Package outline	29
3	Ordering information	2	13	Soldering of SMD packages	30
4	Block diagram	3	13.1	Introduction to soldering	30
5	Pinning information	4	13.2	Wave and reflow soldering	30
5.1	Pinning	4	13.3	Wave soldering	30
5.2	Pin description	4	13.4	Reflow soldering	31
6	Functional description	5	14	Abbreviations	32
6.1	Operating modes	5	15	References	32
6.1.1	Bus activity and idle detection	5	16	Revision history	33
6.2	Mode control pins: STBN and EN	5	17	Legal information	34
6.2.1	Normal mode	12	17.1	Data sheet status	34
6.2.2	Receive-only mode	12	17.2	Definitions	34
6.2.3	Standby mode	12	17.3	Disclaimers	34
6.2.4	Go-to-sleep mode	12	17.4	Licenses	34
6.2.5	Sleep mode	12	17.5	Trademarks	34
6.3	Wake-up mechanism	13	18	Contact information	35
6.3.1	Remote wake-up	13	19	Contents	36
6.3.1.1	Bus wake-up via wake-up pattern	13			
6.3.1.2	Bus wake-up via dedicated FlexRay data frame	13			
6.3.2	Local wake-up via pin WAKE	14			
6.4	Fail-silent behavior	15			
6.4.1	V _{BAT} undervoltage	15			
6.4.2	V _{CC} undervoltage	15			
6.4.3	V _{IO} undervoltage	15			
6.5	Flags	15			
6.5.1	Local wake-up source flag	15			
6.5.2	Remote wake-up source flag	16			
6.5.3	Wake flag	16			
6.5.4	Power-on flag	16			
6.5.5	Temperature medium flag	16			
6.5.6	Temperature high flag	16			
6.5.7	TXEN_BGE clamped flag	16			
6.5.8	Bus error flag	16			
6.5.9	UV _{V_{BAT}} flag	17			
6.5.10	UV _{V_{CC}} flag	17			
6.5.11	UV _{V_{IO}} flag	17			
6.5.12	Error flag	17			

Please be aware that important notices concerning this document and the product(s) described herein, have been included in section 'Legal information'.

