

## NXP Digital terrestrial silicon tuner TDA18211HD

# Raising performance and lowering the cost of set-top box applications

Dedicated for the European terrestrial standard DVB-T, NXP TDA18211HD is a new generation digital terrestrial silicon tuner for digital set-top boxes. Delivering high quality digital TV reception in a single small solution, it reduces overall system cost and cuts design cycles, enabling faster time-to-market while meeting the market's demanding performance and application requirements.

The TDA18211HD incorporates the overall tuning function, including selectivity, in a single chip. With its integrated LNA (Low Noise Amplifier), tracking filter, image rejection mixer and IF filters, it receives the RF signal from the antenna, suppresses unwanted signals and downconverts it to a low IF output. The integrated IF filters support 6/7/8 MHz channel bandwidths. Moreover, the TDA18211 only requires a single 16 MHz crystal for clock generation. A clock signal output is available to synchronize with the channel decoder or feed a slave tuner.

### Key features

- ▶ Dedicated DVB-T silicon tuner
- ▶ Fully integrated RF tracking filters
- ▶ Fully integrated IF selectivity (no need for external SAW filters)
- ▶ Alignment-free
- ▶ RF loop-through for easy STB implementation
- ▶ Fully integrated oscillators
- ▶ Integrated wideband gain control
- ▶ 16 MHz XTAL output buffer for single crystal applications
- ▶ I<sup>2</sup>C interface compatible with 3.3 V and 5 V microcontrollers
- ▶ Single 3.3 V supply
- ▶ Low power consumption

### Key benefits

- ▶ Easy multi-tuner configuration
- ▶ Easy on-board integration
- ▶ Significantly reduces tuner function size

Key parameters (typical)	
Parameter	Value
Frequency range	174 to 864 MHz
Noise figure	5 dB (VHFIII); 7 dB (UHF)
Phase noise	- 85 dBc at 10 kHz
Power dissipation	780 mW
Maximum input level	-5dBm
Image rejection	60 dBc
Sensitivity (DVB-T)	-82dBm (64QAM 2/3)

**Dual DVB-T front-end reference design board OM5776T**

This PCB reference design helps you cut time-to-market even further when creating new systems. It features two TDA18211HD ICs together with two TDA10048HN chips, our latest generation DVB-T channel decoder. A separate module carries the supply for the front-end and provides transport streams to external devices.

The master tuner (top) provides the clock frequency to the slave tuner (bottom), which in turn supplies the clock frequency to both channel decoders. A low profile shielding protects the entire RF section against electromagnetic interference from the external environment.

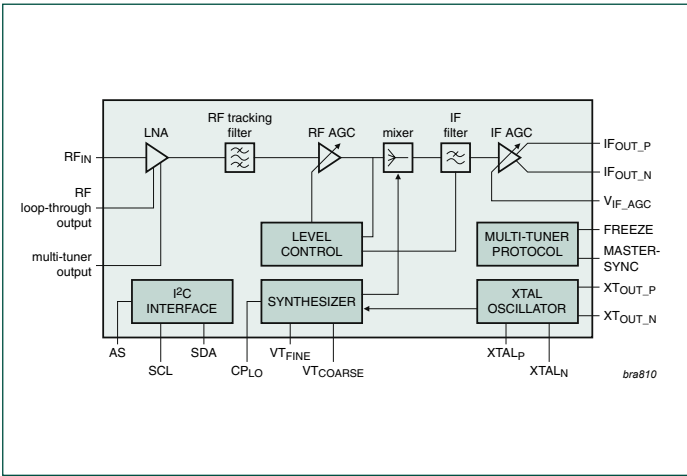

Diagram of TDA18211HD

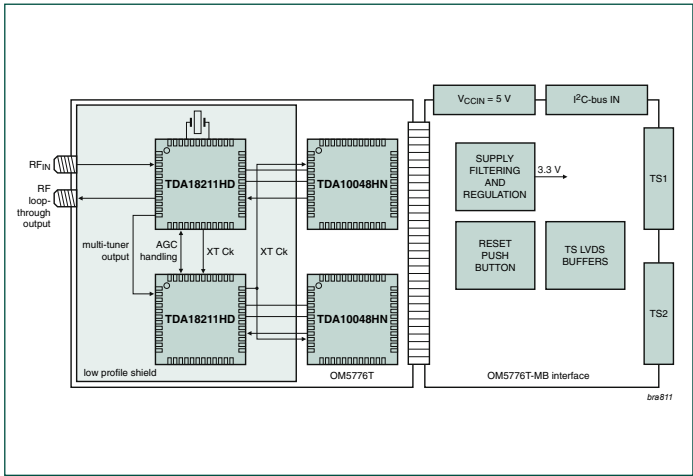

Diagram of OM5776T

