

NXP LED dimmer demonstration board OM6279

Quickly demonstrate keypad and LED functions

This easy-to-use, two-board set-up runs on its own, without additional hardware or software, and makes it simple to demonstrate a wide range of keypad and LED functions.

Key features

- ▶ Versatile LED dimmer demonstrations
 - RGB LED color mixing
 - LED blinking/dimming
 - Backlight LED control
- ▶ Keypad control board
 - Microcontroller, I²C-bus controller, and keypad controller
- ▶ LED display board
 - Four 8-bit I²C LED dimmers and one 4-bit I²C LED dimmer to demonstrate wide range of lighting functions
- ▶ Embedded firmware for out-of-the-box operation
- ▶ Downloadable support tools
- ▶ Application note and data sheets, IBIS model, source code for 8051-type microcontroller (in C, with drivers), Hex files, and third-party support tools

The NXP LED dimmer demo board makes it quick and easy to demonstrate keypad control as well as LED lighting and color mixing.

Built around the NXP 8-bit microcontroller P89LV51RD2 and an NXP I²C-bus controller PCA9564, the board uses embedded software to run demonstrations on its own, without additional hardware or software.

Optimized for use in mobile phones, the microcontroller is equipped with firmware that emulates a cellular handset. Engineers can program a variety of light patterns and control the brightness of a virtual display. The firmware can also be used to emulate a battery-discharge display.

Two-board set-up

The demo board uses two boards, one for keypad control, and one for LED display.

The keypad-control board includes the microcontroller and the I²C-bus controller, plus a 16-key keypad controlled by a 16-bit I²C I/O expander. A 3.3-V voltage regulator provides the demo board's internal power supply, using an external 9-V battery or 9-V mini-plug from a power pack (not included) for its source.

The LED-display board has a total of nineteen LEDs: four white backlight LEDs, eight RGB LEDs, four red LEDs, a blue LED, a green LED, and a red/green bicolor LED. A 4-bit I²C LED dimmer controls backlight dimming. Three 8-bit I²C LED dimmers control the eight

RGB LEDs while a fourth controls the rest of the LEDs, which can be used to demonstrate status or as miscellaneous indicators. Backlight brightness and RGB color mixing are controlled via the keypad.

Downloadable support tools

Supporting items, including application notes, data sheets, an IBIS model, source code for an 8051-type microcontroller (in C language, with drivers), Hex files, and links to third-party tools, are available via the NXP website: www.nxp.com/logic/support/boards/leddemo

Ordering information

To order the demo board, please email i2c.support@nxp.com.

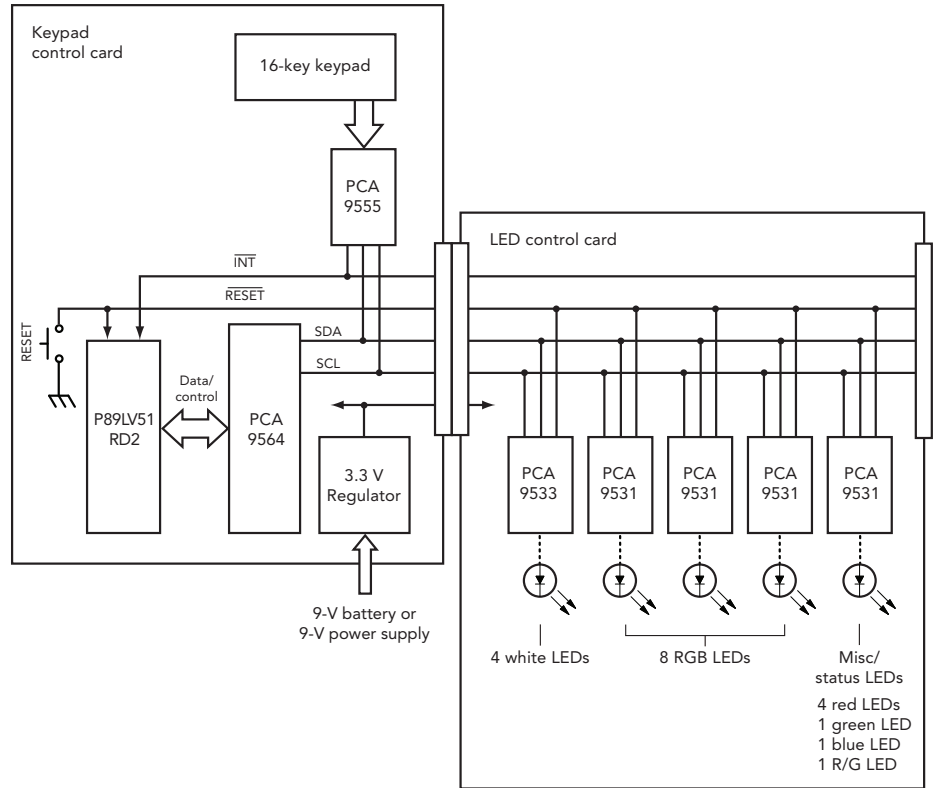

Block diagram of demo board

Demo board components

Type number	Description	Function on demo board
P89LV51RD2BA	Microcontroller	Connect to the 8-bit parallel port and the control signals of the PCA9564, and provide master control of other devices on the board. Uses embedded firmware to emulate cellular phone or battery discharge.
PCA9564PW	I ² C-bus controller	Interface between the P89LV51RD2 microcontroller and the I ² C-bus.
PCA9555PW	I ² C 16-bit GPIO	Control the 16-keypad. Each time a key is pressed, an interrupt is sent to the P89LV51RD2, initiating a read sequence for the master to identify the key.
PCA9531PW	I ² C 8-bit LED dimmer	Control the eight RGB LEDs. There are four dimmers: one for each of the three primary colors, and one to control miscellaneous LEDs. All are programmed via the keypad.
PCA9533DP/01	I ² C 4-bit LED dimmer	Control the four white backlight LEDs. Brightness is controlled via the keypad.