



The most versatile approach to minimizing LIN system overheads

The stand-alone LIN I/O slave UJA1023 is the latest dedicated LIN product from NXP, an acknowledged leader in automotive networking solutions. With many on-chip features, including an integrated LIN2.0 / SAE-J2602 transceiver, it significantly enhances LIN systems and minimizes application-specific overheads.

Key features

- ▶ Automatic bit-rate synchronization to any bit-rate between 1 and 20 kbit/s
- ▶ Integrated LIN2.0 / SAE-J2602 transceiver (including 30 kΩ termination resistor)
- ▶ 8 bi-directional I/O pins
- ▶ 4x4 switch matrix to support reading a maximum number of 16 switches
- ▶ Outputs can be configured as high-and/or low-side driver, can be operated in cyclic or PWM mode
- ▶ Simple 8-bit A/D converter
- ▶ Advanced low-power behavior
- ▶ On-chip oscillator
- ▶ ID configuration via daisy chain or plug coding
- ▶ Inputs support local wake-up and edge capturing
- ▶ Configurable sleep mode
- ▶ Limp home configuration in case of error conditions
- ▶ Extremely low emission
- ▶ High immunity against electromagnetic interference
- ▶ Bus line protected against transients in an automotive environment
- ▶ Extended ambient temperature range (-40 °C to +125 °C)

A fully integrated LIN I/O slave node (LIN physical layer and protocol handling), the UJA1023 delivers a low-cost, single-chip solution for multiple application fields – replacing several components commonly used in control units for input and output handling. It incorporates an automatic bit-rate synchronization circuit, enabling the device to accept any bit-rate between 1 kbit/s and 20 kbit/s.

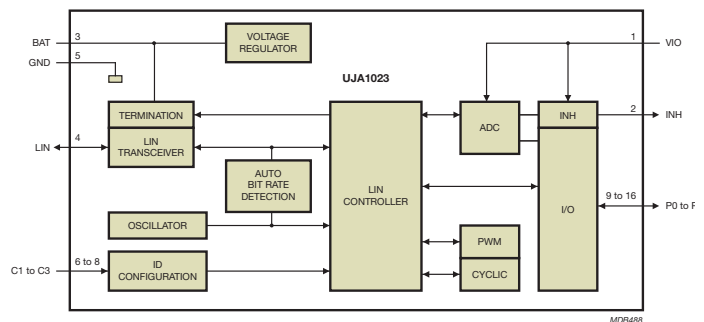

UJA1023 block diagram

The on-chip LIN 2.0 transceiver, together with the LIN2.0 protocol handler, oscillator and 30 kΩ termination resistor necessary for LIN slaves, handles the LIN protocol

autonomously. ID programming is achieved by a master request and slave response message, combined with daisy chain or plug coding function, and the device also has a limp home configuration in case of error conditions, for example when LIN communication stops.

An advanced low-power concept ensures very low power consumption, augmented by an energy-saving, configurable sleep mode that also provides a local wake-up feature. As with all our IVN solutions, the UJA1023 offers extremely low emission and high immunity against electromagnetic interference, while the bus line is protected against automotive transient voltages.

The 8 programmable bi-directional I/O pins can have following functions:

Input	Output
<ul style="list-style-type: none"> • Standard input pin • Local wake-up in case of sleep mode entered • Edge capturing on falling, rising or both edges • Analog input pin • 4x4 switch matrix 	<ul style="list-style-type: none"> • Standard output pin as high-side, low-side or push-pull driver • Cyclic mode for local wake-up • PWM mode, for example for controlling backlight intensity • 4x4 switch matrix

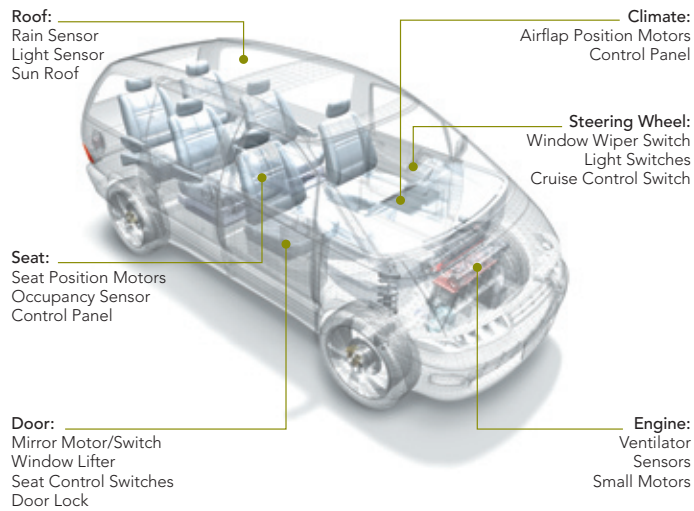

Integrated LIN Slave Nodes - Typical Target Applications

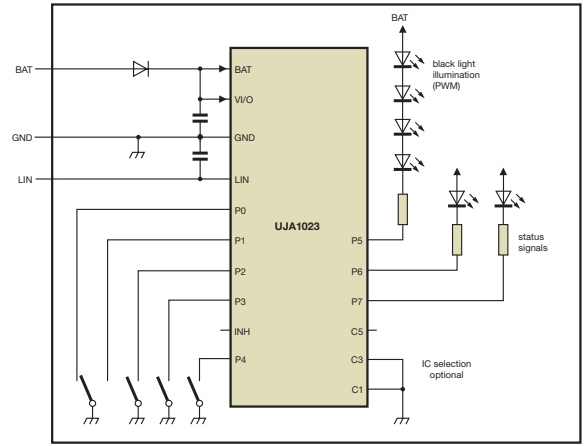

Switch panel with illumination and status feedback

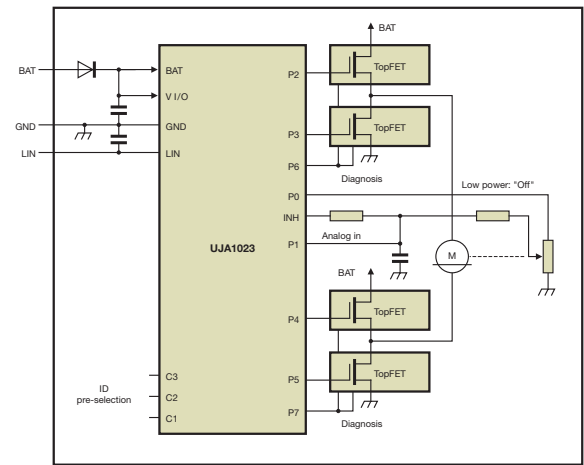

Motor driver with position feed-back



www.nxp.com



NXP Semiconductors is in the process of being established as a separate legal entity in various countries worldwide. This process will be finalized in the course of 2006.

© 2006 Koninklijke Philips Electronics N.V.

All rights reserved. Reproduction in whole or in part is prohibited without the prior written consent of the copyright owner. The information presented in this document does not form part of any quotation or contract, is believed to be accurate and reliable and may be changed without notice. No liability will be accepted by the publisher for any consequence of its use. Publication thereof does not convey nor imply any license under patent- or other industrial or intellectual property rights.

Date of release: September 2006
Document order number: 9397 750 15749
Printed in the Netherlands