

Nexperia IP Camera Reference Design for security and surveillance applications

Customizable hardware and software for network-based security cameras

Network-based 'IP' security cameras combine traditional still image and video capture with digital video processing and networking features, offering more robust functionality than their analog predecessors. Installed quickly and easily, IP cameras give security professionals access to surveillance data from virtually anywhere, at anytime.

Key features

- Includes NXP PNX1502 media processor-based reference board, software, and customization tools
- High-performance MPEG-4 SP encoding up to 30 fps D1
- Audio encoding: G.711, G.726, AAC
- ISMA-compliant streaming using RTP/RTSP/RTCP
- HTTP server module for administration and configuration
- UPnP support
- Supports Micron CMOS sensor modules
- 10/100 Ethernet interface; optional PCI interface for expansion (802.11x or removable media)
- DLNA-compliant software ensures cross-product interoperability
- Nexperia software development kit for custom application development

The Nexperia™ IP Camera Reference Design provides a complete solution for developing networked IP cameras for security and surveillance applications. It leverages the power and flexibility of an NXP PNX1502 media processor and Alarity software to bring the latest digital media features—high-quality MPEG-4 video encoding, a choice of audio encoding, and an HTTP server for authorized access from any browser—to security applications. Modular hardware, media codecs, libraries, application examples, and customization tools make it easy for manufacturers to build prototypes and production-ready products.

High-quality media processing

The reference design utilizes Alarity's MPEG-4 video encoding library for high

quality, real-time encoding of resolutions up to D1. Proprietary, highly efficient motion estimation and zero DCT coefficient prediction algorithms significantly reduce computational complexity and power consumption. A proprietary optimized rate control algorithm supports a wide range of resolutions and allows flexible speed/quality tuning.

For security applications with audio requirements, the reference design supports a choice of audio formats. Both video and audio encode (for capture and/or storage) and decode (for playback or analysis) are handled by the PNX1502 media processor.

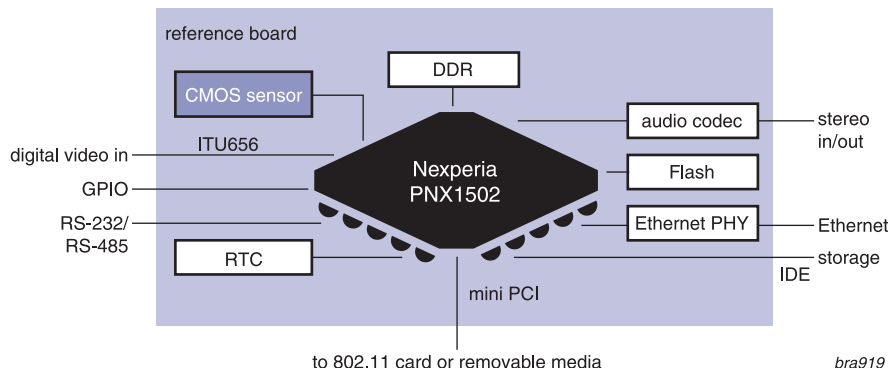

Easy to customize

An HTTP server component enables any authorized HTTP browser to configure and control the IP camera. No special application software or plug-ins are required. The server's user-friendly interface can be customized for end-user, administrative, and configuration purposes.

The reference design's modular hardware is configured for easy prototyping. Several CMOS sensors are supported allowing camera designs to be optimized for high quality or low cost to suit customer requirements.

Also included, the Nexperia Media Player Software Development Kit (SDK) enables development of customized security applications entirely in C/C++. The SDK is supported by a worldwide network of NXP software developers and includes lifetime upgrades and online technical support.

The reference design includes source code for example applications showing developers how to creatively implement unique usecases, configure and initialize

video encoding and streaming, and more. New applications are easily developed by modifying these examples, existing HTTP pages, or CGI functions.

Availability

The reference design is available through Alarity Corporation. Alarity offers software and hardware customization services such as integrating a customer's choice of sensor, adding/removing peripherals, etc. For more information, visit www.alarity.com.



About Alarity

Headquartered in Rutherford, NJ, Alarity Corporation is a solution provider focused on advanced information technologies. Alarity provides exceptional IP solutions and services in media, digital signal processing, multimedia, and information security applications.

Specifications

Reference design

Hardware	Reference board, cables
Software	MPEG-4 encoder, streaming libraries, BSP other required libraries, source code for example applications
Documentation	User guides, schematics, Gerber files, BOM

Reference board

Media processor	Nexperia PNX1502 with TriMedia TM3260 CPU
Memory	64-MB DDR SDRAM
Flash	16-MB NOR
PCI/XIO	32-bit, 33-MHz
Video sensors	CMOS Micron MT9T001 or MISOC2010 included
Audio codec	NXP UDA1380 stereo audio encoder/decoder
Audio I/O	Line in
Connectivity	miniPCI extension board connector (for 802.11 card or removable media), Ethernet 10/100 RJ-45, RS-232/RS-485, GPIO connectors/buttons/LEDS

Supported media formats

Video encode	MPEG-4 SP, ASP, ISMA-compliant streaming
Audio encode	AAC, G.711, G.726
Communications	TCP/IP, RS-232

Software and interoperability

Standards	ISMA, RTP/RTSP/SDP (RFC1889, RFC2326, RFC2327), DLNA 1.0 guidelines, TSSA-compliant component structure
-----------	---

www.nxp.com



© 2006 NXP B.V.

All rights reserved. Reproduction in whole or in part is prohibited without the prior written consent of the copyright owner. The information presented in this document does not form part of any quotation or contract, is believed to be accurate and reliable and may be changed without notice. No liability will be accepted by the publisher for any consequence of its use. Publication thereof does not convey nor imply any license under patent- or other industrial or intellectual property rights.

Date of release: November 2006

Document order number: 9397 750 15821

Printed in the USA