



NXP PCI Express dual-channel, PC TV capture/encode IC, SAA7164E

Two-channel analog/digital PC TV engine for endless watch & record combinations

The PCI Express dual-channel, PC TV capture/encode IC, SAA7164E enables a variety of watch-record, watch-search, record-listen and other popular TV and PVR features on PCs.

Key features

- Dual-channel processing handles two independent TV, video and audio streams
- Enables simultaneous watch-and-record, watch two streams, record two streams (different formats, rates or resolutions)
- Worldwide TV video/audio decoder supports current and legacy standards
- Supports a wide range of channel decoders: ATSC, DVB, ISDB and more
- Multi-standard digital video/audio encoder supports PVR, time-shift, and other recording features (with PC host)
- Multi-standard low-IF demodulation supports NXP silicon tuners
- Captures dual transport streams (serial or parallel) from digital TV demodulators
- Integrated RC receiver/transmitter
- Exceptional video quality achieved by adaptive, 3D comb filter, 3D noise reduction, and subpixel-accurate scaling
- PCI Express X1 interface

The SAA7164E's dual-stream architecture enables two independent digital video streams (TV and/or digital video) to be captured and encoded concurrently. It demodulates and decodes analog TV (video and stereo audio) from innovative silicon tuners, high-performance can tuners and a variety of channel decoders. It captures worldwide digital TV broadcast standards enabling support for a variety of hybrid (analog/digital) receiver designs. State-of-the-art video compression engines encode AV streams for features such as PVR, time shifting, and streaming media content to the PC or portable devices. Video and audio can also be captured from camcorders, VCRs, and cameras, and recorded to HDD, CD, and DVD.

Exceptional picture quality is achieved through advanced features such as low-noise, high-quality ADCs, subpixel-

accurate scaling, adaptive 3D comb filters and 3D noise reduction. Certified three-level Macrovision® detection circuitry ensures the video's original analog copy protection remains intact. Premium TV content is protected through 128-bit AES and (T)DES encryption. Dual-channel vertical blanking interval (VBI) data slicing is supported for most worldwide standards. The SAA7164E's PCI Express (PCIe) 1.1-compliant architecture ensures ample bandwidth for multichannel features.

Software and reference designs

The SAA7164E has a high-level command and response interface (CRI). Broadcast driver architecture (BDA) drivers and protected BDA (PBDA) drivers (included) use the CRI for plug-and-play applications. Reference designs are available for various combinations of analog and digital TV signal sources.



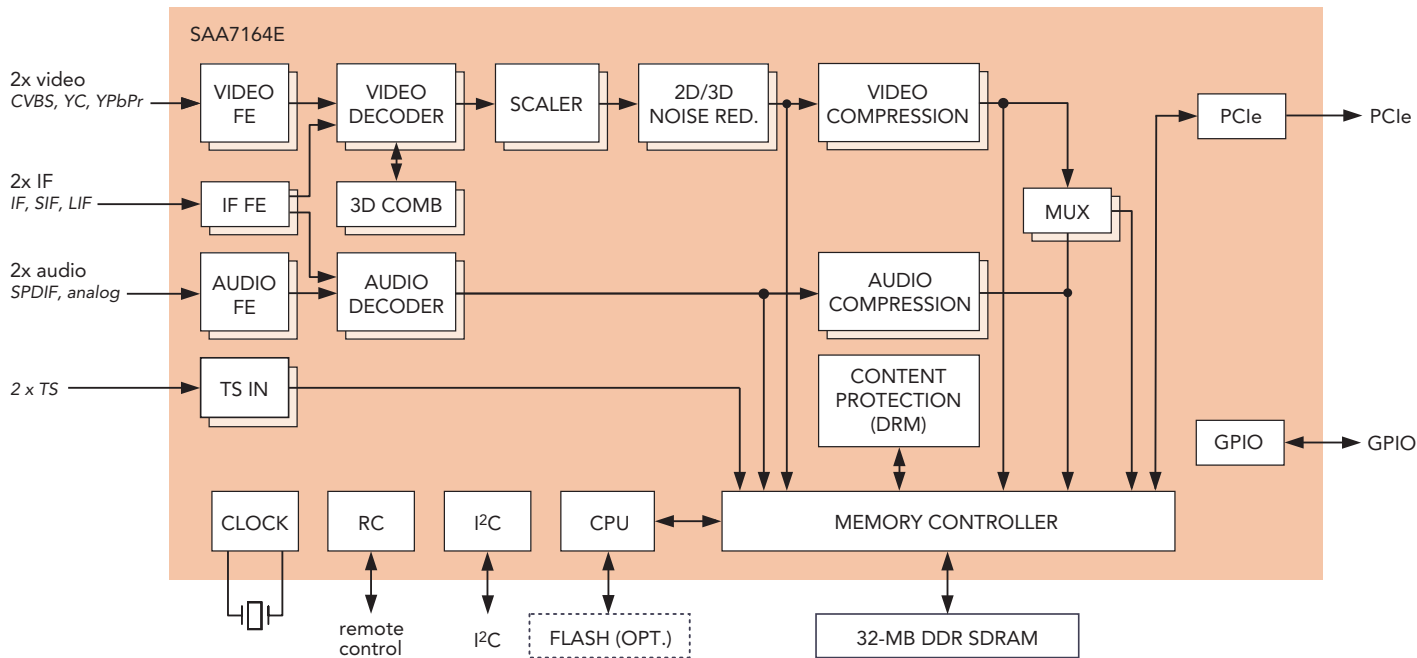

Specifications

Video/audio capture and decoding

- Worldwide analog TV SIF, IF, low-IF demodulation standards: M/N, B/G/H, D/K, I, L/L'
- Worldwide TV standards
 - PAL BGDHIN, PAL M, Combination PAL N, NTSC M, NTSC Japan, NTSC 4.43, SECAM
 - BTSC (optional dbx™ noise reduction), SAP, EIAJ, NICAM, FM A2, and AM
 - ATSC, DVB and ISDB transport streams
- Flexible video resolution
 - 70x64 up to 720x576 at 25 fps or 720x480 at 30 fps
 - D1 progressive (720x576 at 50 fps or 720x480 at 60 fps; single stream)
- FM radio with RDS
- Worldwide VBI text and data services
- Video from camcorders, VCRs, etc.: CVBS, SSIF, S-video (Y/C), YPbPr (RGB)
- Macrovision 1.0 copy protection detection

- Adaptive spatial and temporal 3D comb filter (NTSC/PAL)
- Advanced 3D noise filter
- Horizontal and vertical down scaling
- WM digital rights management

Digital video encoding

- H.263, MPEG-1, MPEG-2 (MP@ML), MPEG-4 (SP, ASP), DivX (V4, V5), XviD, VC-1 (SP, MP, AP), WMV
- Bit rates up to 15 Mbit/s, CBR/VBR
- Reverse telecine (3:2 pulldown)
- 128-bit AES or (T)DES video encryption
- Content management support

Stream output formats

- TS, PS (DVD, SVCD), AVI, MOV, MP4 and ASF container

Digital audio encoding

- Dolby AC-3®, MPEG 1 L2, MP3, AAC-LC, WMA
- Bitrates: 64 kbit/s up to 448 kbit/s

Interfaces

- Stereo baseband audio: three inputs, one output
- SPDIF: two differential and two single-ended inputs; one single-ended output
- Two independent transport stream inputs, serial or parallel, 480p, 576p, 720p, 1080i
- Remote control: one IR receiver, two IR transmitters, all common TX standards
- Clock Xtal: main 54-MHz, secondary 24.576-MHz
- PCI Express Specification 1.1
- Three master and slave I2C bus ports
- One serial peripheral interface (SPI)
- Eight GPIO pins for general I/O or IRQs
- 16-bit DDR SDRAM width
- 90-nm CMOS BGA364

Use of this product in any manner that complies with the MPEG-2 Standard is expressly prohibited without a license under applicable patents in the MPEG-2 patent portfolio, which license is available from MPEG LA, L.L.C., 250 Steele Street, Suite 300, Denver, Colorado 80206.

Dolby AC-3 is a registered trademark of Dolby Laboratories. Other brands and product names are trademarks or registered trademarks of their respective owners.

www.nxp.com



© 2007 NXP B.V.

All rights reserved. Reproduction in whole or in part is prohibited without the prior written consent of the copyright owner. The information presented in this document does not form part of any quotation or contract, is believed to be accurate and reliable and may be changed without notice. No liability will be accepted by the publisher for any consequence of its use. Publication thereof does not convey nor imply any license under patent- or other industrial or intellectual property rights.

Date of release: February 2007

Document order number: 9397 750 15870

Printed in the USA