



## NXP GreenChip PC power-supply solution with TEA1771, TEA1781, and TEA1782

# Unrivalled efficiency and price for PC power supplies

This complete, cost-effective solution enables PC power supplies that surpass consumer and industry expectations for high efficiency and low noise. It also cuts power losses by up to 30% and reduces or even eliminates the need for a cooling fan.

### Key features

- ▶ Complete, cost-effective PC power-supply (silverbox) solution
  - NXP GreenChip PC primary control IC TEA1771
  - NXP GreenChip PC secondary control IC TEA1781
  - NXP GreenChip secondary control and standby IC TEA1782
- ▶ Innovative controlled-switch concept
- ▶ Feed-forward regulation
- ▶ Active clamp reset
- ▶ Zero-voltage switching

### Key benefits

- ▶ Reduced system cost
- ▶ Increased efficiency
  - Meets EnergyStar and other efficiency requirements
  - Supports platform design
- ▶ High-output voltage accuracy
- ▶ Improved power density
- ▶ Low external-component count
- ▶ No cross regulation

The NXP GreenChip PC power-supply (silverbox) solution uses innovative design techniques to increase efficiency, lower noise, and reduce the bill of materials. It also cuts power losses by up to 30% and reduces or even eliminates the need for a cooling fan.

Several features, including a controlled-switch concept, combine to boost efficiency, so the design can use less expensive components with lower breakdown voltages.

On the primary side, the solution uses feed-forward regulation with an integrated reset switch for the active clamp. For control and rectification of the secondary side, the solution uses bi-directional switches, instead of Schottky diodes. NXP TrenchMOS FETs are recommended for control of the secondary side.

The solution doesn't need post regulation or a separate standby, so fewer ICs are required and power losses are reduced.

Reset winding has also been eliminated, and, to simplify the transformer design, secondary windings can be kept to a minimum.

To help reduce electromagnetic interference and primary-side switching losses, the GreenChip PC solution includes valley detection for zero-voltage switching.

Higher switching frequencies are possible because the magnetic components required to boost power density can be smaller.

The GreenChip PC is designed for flexibility and longevity. As new and increasingly strict industry requirements and government regulations are put in place, the efficiency of the GreenChip PC solution can be upgraded by replacing the MOSFETs with versions that have a lower  $R_{DS(on)}$  rating.

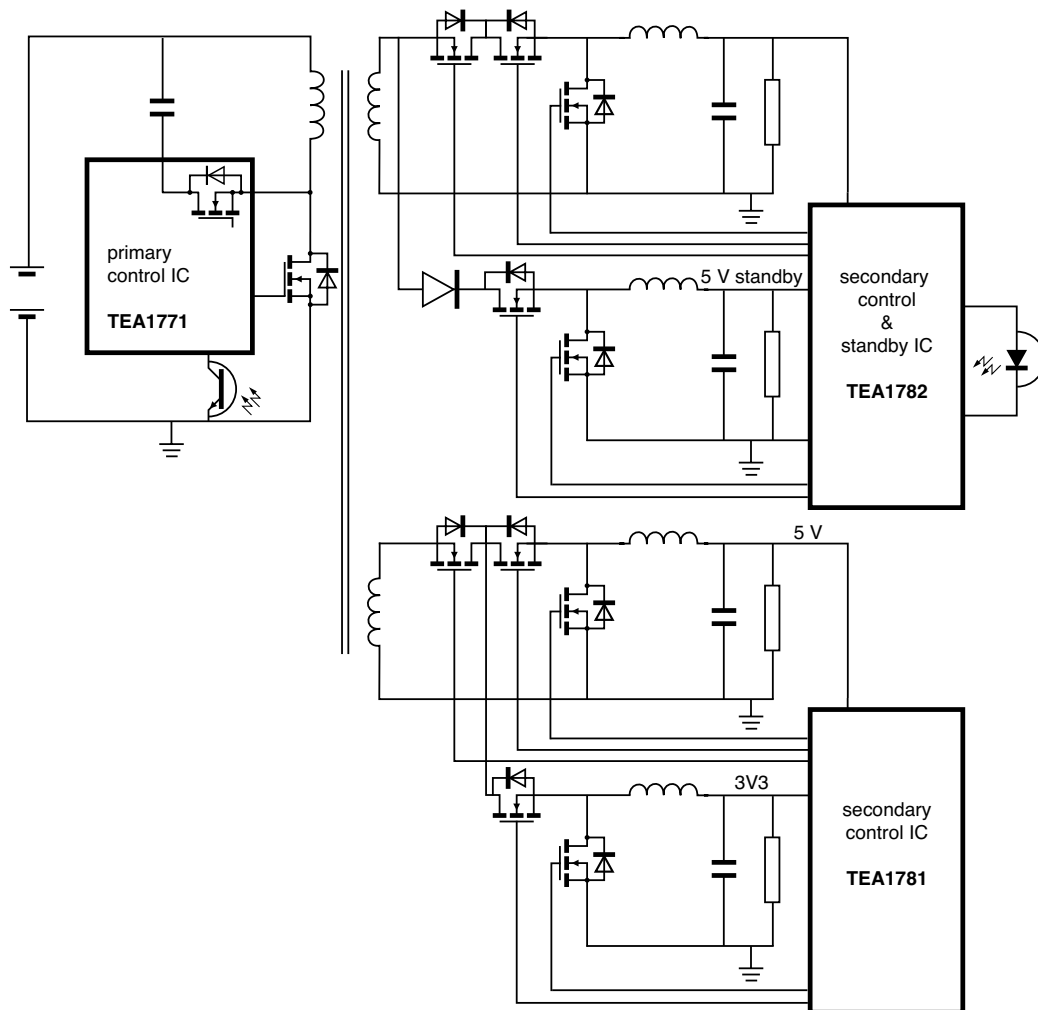

Block diagram of the NXP GreenChip PC solution