



## NXP GreenChip III TEA1750

# Highly efficient, reliable SMPS control for power supplies above 75 W

Special built-in green functions, along with integrated controllers for PFC and flyback, mean this third-generation SMPS controller IC delivers high efficiency at all power levels. High integration reduces external component count and lowers overall cost.

### Key features

- ▶ Integrated PFC and flyback controllers
- ▶ Universal mains supply operation to 276 V
- ▶ On-chip start-up current source
- ▶ Patented green features
  - Valley/zero-voltage switching for minimum switching losses
  - Burst mode operation when low load is detected at flyback output
- ▶ Protection features
  - Safe restart mode for system fault conditions
  - Patented continuous mode protection via demagnetization detection for both converters
  - Under-voltage protection for both converters
  - Accurate over-voltage protection for both converters
- ▶ SO16 package

### Applications

- ▶ Notebook adapters
- ▶ Power-supply solutions from 75 to 250 W

The NXP GreenChip III TEA1750 is a third-generation switched-mode power supply (SMPS) IC that integrates a controller for power factor correction (PFC) and a flyback controller.

Housed in a small SO16 package, it delivers cost-effective operation with a low number of external components, and is ideally suited for use in notebook adapters and other power-supply solutions in the range from 75 to 250 W.

It includes special built-in green functions that enable high efficiency at all power levels. This holds true for quasi-resonant operation at high power levels, for quasi-resonant operation with valley skipping, and even for reduced-frequency operation at lower power levels.

At low (standby) power levels, the PFC switches to burst-mode control to maintain high efficiency. In burst mode, soft-start and soft-stop are added to eliminate audible noise.

The proprietary high-voltage BCD800 process makes direct start-up possible from the rectified universal mains voltage in an effective and green way. A second, low-voltage SOI IC is used for accurate, high-speed protection functions and control.

The PFC and flyback converters use a patented scheme for continuous mode protection via demagnetization detection. Both converters have under-voltage protection (foldback during overload), and accurate over-voltage protection. Protection in the flyback controller is adjustable.

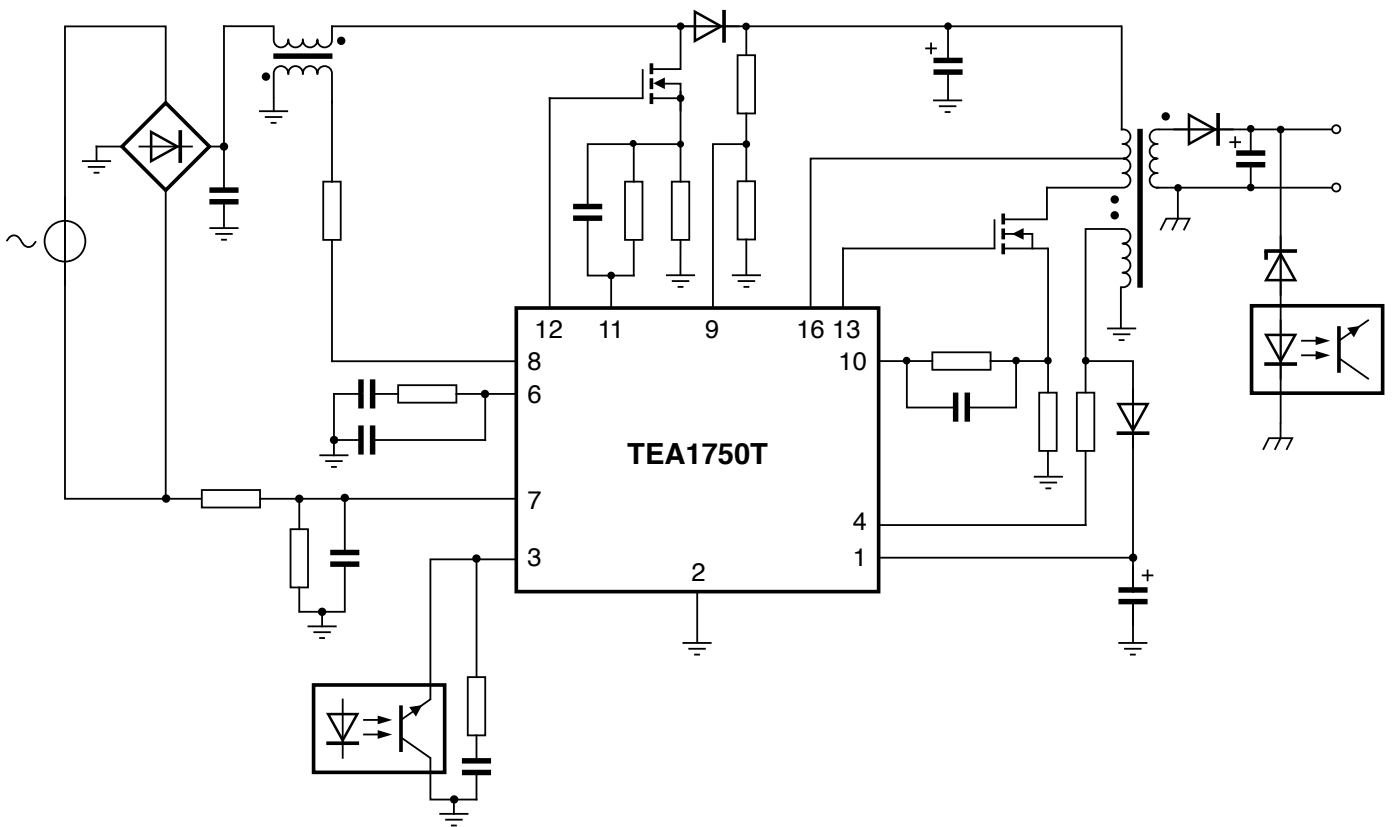

GreenChip III block diagram