

NXP AC/DC converter for high-power LED strings

The power behind vibrant solid-state lighting

NXP's high-power AC/DC converter reference design enables fast proof-of-concept for single-color LED applications. It's a fully tested solution based on robust components and proven technologies that simplifies the design of solid-state lighting (SSL) luminaires.

Key benefits

- ▶ Efficient power conversion from mains
 - Maximize energy efficiency and minimize form factor through reduced heat generation
- ▶ Accurately controlled current through the LEDs
- ▶ Meets regulations
 - Isolated for safety
 - Power Factor Correction above 25 W
- ▶ LED dimming through current control

Key applications

- ▶ Decorative lighting
- ▶ Commercial lighting e.g. freezer lights
- ▶ Cove lighting
- ▶ White spotlights
- ▶ Other lighting applications

Connecting directly to the mains, our AC/DC converter reference design for high-power LED strings distributes power to local or distributed light engines. Optimized for driving 25 high-power LEDs in series at 350 mA (giving a total $V_{F(LED)}$ of approximately 70 V), it can be easily adapted for different voltage and/or current requirements.

The reference design supports LED dimming through current reduction, for example, via a logarithmic variable resistor (potentiometer). This allows dimming to less than 2% to be achieved.

NXP offers a wide range of fly-back converters suited to SSL applications from our GreenChip™ Switched Mode Power Supply (SMPS) control IC family. The demonstration board based on this reference design uses NXP's TEA1530, which offers an efficient fly-back converter concept for power requirements above 25 W.

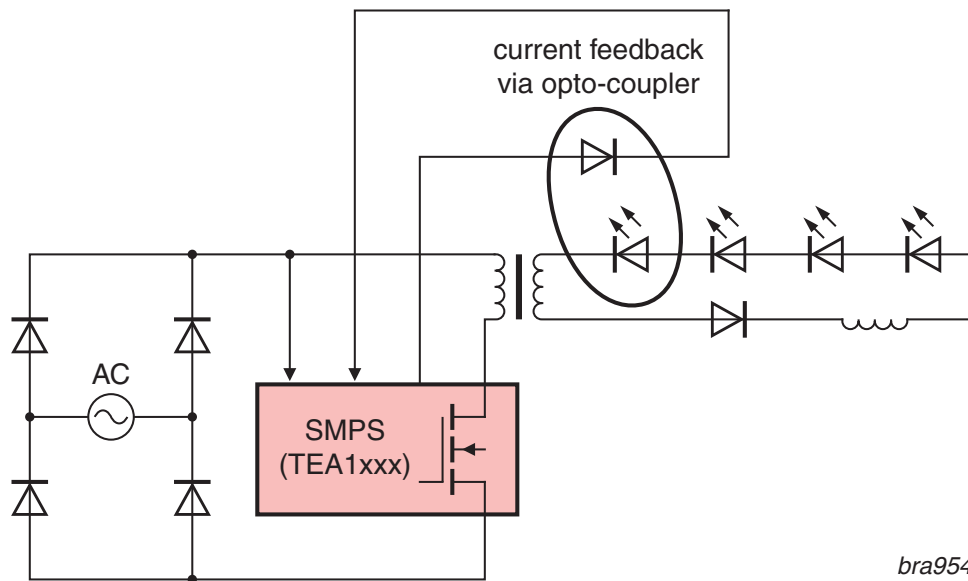

Key components

SMPS control ICs for low-power systems TEA152x

- ▶ Operates from universal mains supply (80 – 276 VAC)
- ▶ Integrated 650 V MOSFET
- ▶ Power requirements up to 25 W
- ▶ High-voltage start-up
- ▶ Highly integrated
- ▶ High efficiency

SMPS control ICs for high-power systems TEA153x

- ▶ Operates from universal mains supply (70 – 276 VAC)
- ▶ High-voltage start-up
- ▶ Power requirements above 25 W
- ▶ Low standby power
- ▶ High efficiency
- ▶ External Power Factor Correction

Flyback control IC TEA1750

- ▶ Operates from universal mains supply (70 – 276 VAC)
- ▶ High-voltage start-up
- ▶ Power requirements between 25 W and ca. 150 W (PFC needed)
- ▶ High efficiency
- ▶ Integrated Power Factor Correction
- ▶ Very low external component count

Resonant converter controller TEA161x

- ▶ Power requirements > 150W
- ▶ High efficiency
- ▶ Integrated high-voltage level-shift function
- ▶ Adjustable dead-time