



## NXP fully integrated down converter (PLL synthesizer/mixer/amplifier) TFF1004HN for satellite LNB

# Create a Ku-band DVB-S LNB for less, with higher reliability

The TFF1004HN is an integrated downconverter for use in Low Noise Block (LNB) converters in a 10.7 GHz to 12.75 GHz Ku band satellite receiver system. This alignment-free concept replaces current solutions that require components such as GaAs mixer and DRO. As part of our LNB chipset, it enables a Ku-band satellite receiver that lowers total cost of ownership and guarantees the stability of the local oscillator.

### Key features

- ▶ Pre-amplifier, mixer, buffer amplifier, and PLL synthesizer in one IC
- ▶ State-of-the-art SiGe BiCMOS process
- ▶ Alignment-free concept
- ▶ LO frequency with XTAL control
- ▶ Low phase noise
- ▶ Switched LO frequency: 9.75 and 10.6 GHz
- ▶ Low spurious
- ▶ HVQFN24 package (4 x 4 x 0.85 mm)
- ▶ Part of complete LNB chipset
  - NXP UAF3000TS for supply and band/polarization switching
  - NXP BFU725F for 2<sup>nd</sup> LNA stage
- ▶ Demo board available

### Application

- ▶ Ku-band DVB-S receiver



Designed for use in the Low Noise Block (LNB) of a Ku-band satellite receiver for Asian and European standards, the NXP TFF1004HN is a highly integrated IC that includes an LNA, a mixer, a down-converter, a PLL, a crystal oscillator, and an IF buffer.

It is manufactured in NXP's breakthrough SiGe BiCMOS process for microwave applications, which is more cost-effective than GaAs processes and more reliable than discrete implementations.

To comply with Asian and European DVB-S standards, the TFF1004HN supports RF input frequencies between 10.7 and 12.75 GHz, and uses a selectable LO that operates at 9.75 or 10.6 GHz.

It is housed in a small HVQFN24 package that measures only 4 x 4 x 0.85 mm, and is designed to work as part of a complete chipset that provides a total LNB solution.

## Complete LNB chipset

The chipset consists of the TFF1004HN, the UAF3000TS, and the BFU725F.

The UAF3000TS is a FET bias controller with a polarization switch and tone detection. It provides biasing for up to three LNA devices. An integrated bandgap reference ensures the accuracy of voltage and tone detection, also over temperature. For horizontal and vertical switching, there is an integrated supply-voltage detector, and for switching between high and low bands, there is a 22-kHz tone detector. The supply voltage range, 3.3 V or 5 V, is detected automatically.

The BFU725F is an NPN microwave transistor for high-speed, low-noise applications. In the LNB chipset, it is used for the second LNA stage. It is manufactured in a 110-GHz fT-SiGeC technology, so it delivers an excellent noise figure (1.0 dB at 12 GHz), and a high maximum stable gain (13 dB at 12 GHz).

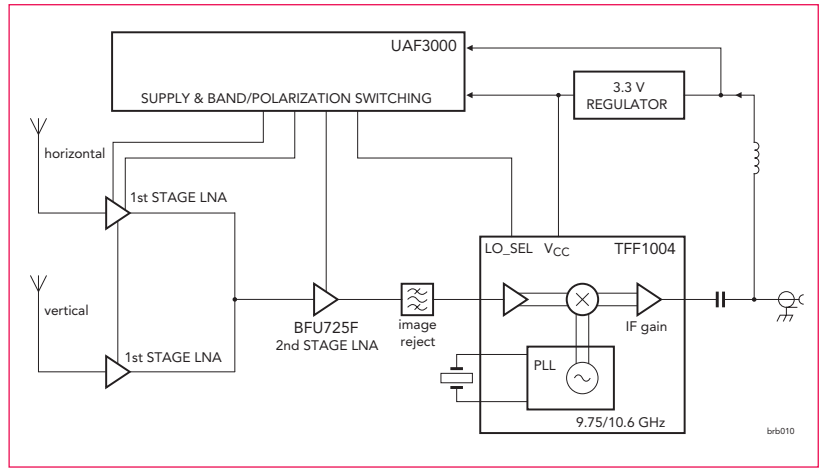

LNB application with TFF1004HN, UAF3000TS, and BFU725F

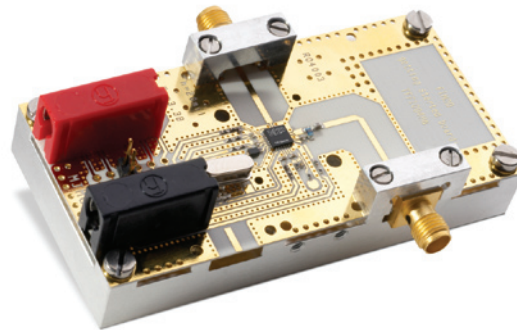

TFF1004HN demo board

## Operating characteristics

TFF1004HN	Input frequency range (GHz)	Conversion gain $G_c$ (dB)	Noise figure NF (dB)	Output IP3 $IP3(out)$ (dB)	Switched LO frequency (GHz)
	10.7 to 12.75	32	9	10	9.75 / 10.6
BFU725F	Typ. collector current $I_{C(max)}$ (mA)	Transition frequency $f_T$ (GHz)	Noise figure NF (dB) @ 12 GHz	Max. stable power gain $MSG/G_{P(max)}$ (dB) @ 12 GHz	Collector-emitter breakdown voltage $BV_{CEO}$ (V)
	8	68	1.0	13	3.2
UAF3000TS	Supply voltage $V_{CC}$ (V)	Drain voltage $V_D$ (V)	Drain current $I_{DO}$ (mA)	Supply current $I_{CC}$ (mA)	Polarization detection voltage $VPOL$ (V)
	3.3 or 5	2	10	6	14.75