



## NXP PCI Express hybrid (DVB-T/analog) PC TV Mini card reference design PCV540

# Watch and record TV on notebooks and other compact PCs

The highly integrated PCV540 reference design brings hybrid TV reception and DVR features to power-conscious notebook PCs and specialty form factors such as compact 'all-in-one' PCs. On a small PCIe Mini card, the PCV540 handles complete TV functionality including worldwide analog TV tuning, DVB-T digital TV tuning and demodulation, analog TV video/stereo decoding, and multi-format digital A/V encoding — making it an ideal choice for products in Europe and other DVB-T markets.

### Key features

- Hybrid TV reception: worldwide analog and DVB-T digital standards
- PCI Express Mini card form factor
- Supports TV viewing and recording
- Captures baseband A/V from CE devices
- High-performance, hybrid silicon tuner NXP TDA18271

### Features NXP SAA7163FE IC

- Single-channel analog TV video and sound decoding
- Digital transport stream capture
- Multi-format digital A/V encoding for DVR and time-shift features (with host PC)
- Vibrant picture quality through advanced 3D comb filters and 3D noise reduction

A complete, low-BOM reference design, the PCV540 processes hybrid TV streams using only a few key components: a low-noise multi-standard tuner, a low-power DVB-T channel decoder, and the highly integrated SAA7163FE PC TV IC. In addition to decoding broadcast TV video and stereo, the SAA7163FE encodes analog A/V for recording features in hardware. By off-loading the host CPU of this cycle-consuming task, it enables PC manufacturers to utilize lower-cost CPUs without compromising performance or picture quality.

The SAA7163FE ensures high-quality reception under the most demanding conditions through advanced 3D comb

filtering, 3D noise reduction and dynamic echo cancellation. It also handles high-quality scaling, vertical blanking interval extraction, remote control support for TV and recording, multi-layer content protection (Macrovision® detection), and CGMS-A extraction.

PCV540 is supported on popular Windows operating systems and third-party TV/DVR applications. Board setup and control is handled through the Windows WDM driver AVStream Class with BDA Extensions. The reference design includes a PCIe Mini card, all necessary drivers, a user manual, schematics, a BOM, Gerber files, and documentation.



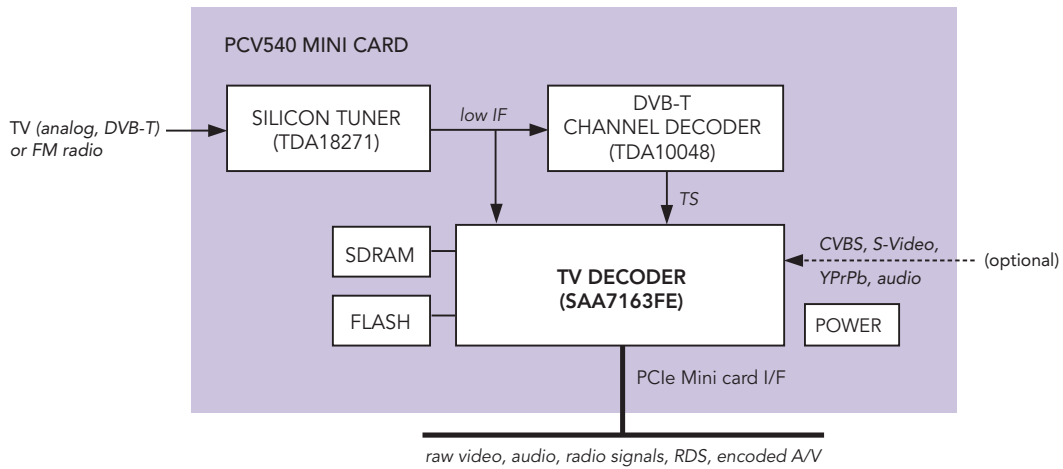

## Specifications

### PCV540 includes

- Reference board
- Drivers
- User manual, schematics, BOM, Gerber files, documentation

### Reference board

- PCIe host bus interface, Mini card full-profile form factor
- Separate RF connectors for digital cable TV, analog TV, and FM radio
- NXP TDA18271 hybrid TV tuner
  - analog: PAL, SECAM, NTSC
  - digital: DVB-T, DVB-C, ATSC and ISDBT
- NXP TDA10048 DVB-T channel decoder
- NXP SAA7163FE PC TV IC
- 32-MB DDR RAM
- 3 switched supply regulators
- 4-MB Flash memory footprint; Flash memory (ST M25P32) optional
- (opt.) 1 external IR receiver/ transmitter

### SAA7163FE PC TV capture/encode IC

- Single channel
- Worldwide analog TV video decoding: NTSC M, NTSC Japan, NTSC 4.43, PAL BGDHIN, PAL M, Combination PAL N, SECAM L/L'
- Worldwide analog TV sound decoding: BTSC, SAP, EIAJ, NICAM, FM A2, FM radio
- A/V encode: MPEG-1/2/4, WMV, DivX, and AAC-LC
- Audio formats MP3, MPEG1L2, Dolby Digital® (2-channel)
- Worldwide VBI text and data services
- 3D comb filter and 2D/3D noise reduction
- Processes CVBS, S-Video and component

### Operating system support

- Microsoft Windows XP
- Windows MCE 2005
- Windows Vista (32- and 64-bit support)

### Certifications

- RoHS compliant
- PCIe 1.1 compliant
- Macrovision Detect specification Revision 1.00

Use of this product in any manner that complies with the MPEG-2 Standard is expressly prohibited without a license under applicable patents in the MPEG-2 patent portfolio, which license is available from MPEG LA, L.L.C., 250 Steele Street, Suite 300, Denver, Colorado 80206.

Dolby Digital is a registered trademark of Dolby Laboratories, Inc.

www.nxp.com



© 2007 NXP B.V.

All rights reserved. Reproduction in whole or in part is prohibited without the prior written consent of the copyright owner. The information presented in this document does not form part of any quotation or contract, is believed to be accurate and reliable and may be changed without notice. No liability will be accepted by the publisher for any consequence of its use. Publication thereof does not convey nor imply any license under patent- or other industrial or intellectual property rights.

Date of release: December 2007

Document order number: 9397 750 16219

Printed in the USA