



CCM PFC, DCM PFC and ultrafast recovery diodes

High-efficiency power diodes for SMPS

NXP Power Factor Correction (PFC) and ultrafast recovery diodes improve efficiency in Switched-Mode Power Supply (SMPS) applications by delivering the best V_F and t_{rr} trade-off to power dissipation, along with very soft recovery performance.

Active PFC is an electronic system that controls the amount of power drawn by a load in order to obtain a power factor as close as possible to unity. In most applications, the active PFC controls the input current of the load so that the current waveform is proportional to the mains voltage waveform.

Active PFC is related to the reduction of the harmonic content, and/or the aligning of the phase angle of incoming current. PFC is required to reduce disturbance on the AC distribution net and maximize the real power drawn by the power supply from the AC line.

Key features

- ▶ Competitive and customer oriented product portfolio:
 - Roadmap shows a continuous process of development
 - Customer-driven innovation and customized products
 - Best trade-off on V_F to t_{rr} for power diodes achieving highest power efficiency under working mode
- ▶ Superb application know-how and instant technical support:
 - Focus on specific application knowledge
 - Labs with complete testing capabilities, strategically located close to customers in Europe and China

- ▶ Experienced development team with expertise in device physics
- ▶ Well-controlled manufacturing and robust supply chain

Key benefits

- ▶ Fully compliant with regional regulations imposing restrictions on power factor and Total Harmonic Distortion (THD) in high-power applications (> 75 W), including:
 - CCC (or '3'C) in China
 - IEC1000-3-2/EN61000-3-2 in Europe
 - 80 PLUS in America
 - JICC61000-3-2 in Japan
- ▶ Meets energy saving and 'green energy' trends to minimize power costs
- ▶ Optimizes and improves circuit performance:
 - Reduces mains harmonic content
 - Decreases peak current at mains frequency
 - Minimizes the electrolytic bulk capacitor used at PFC stage output
 - Reduces transformer size and weight
 - Improves output regulation of downstream DC-to-DC converters

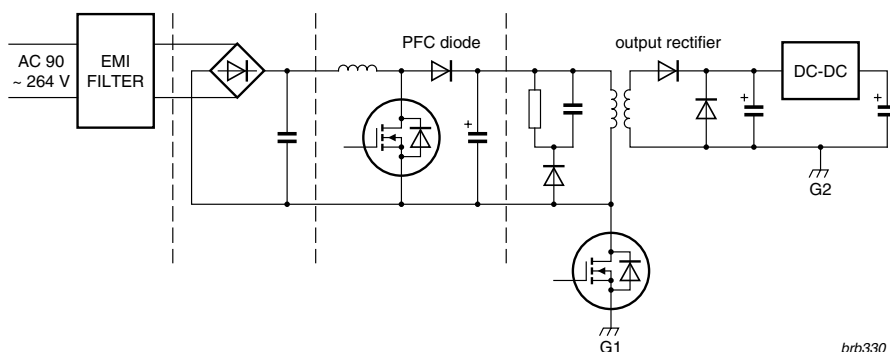

Dissipation in the boost converter PFC circuit

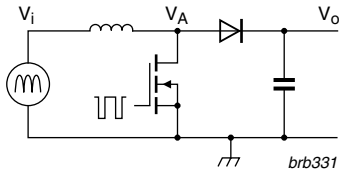

Fig 1. Elementary boost converter PFC circuit

Figure 1 represents a simplified structure of the primary stage of an AC-to-DC boost converter PFC circuit of an SMPS application. Power dissipation is the most important criterion for circuit design. In the boost converter, power dissipation is composed of:

1. On-state losses at the PFC diode
2. Switch-off losses at the PFC diode
3. On-state losses at the MOSFET
4. Switch-on losses at the PFC diode
5. Switching (gate-charge) losses of the MOSFET

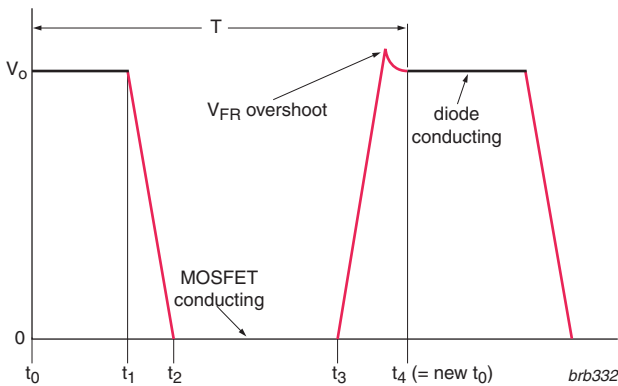

Fig 2. Time-voltage diagram of node A (V_A)

time period	operation	total energy loss
t_0 to t_1	diode conducts	$\frac{P_o}{V_i} \cdot V_F \cdot \left(1 - \frac{V_i}{V_o}\right) \cdot T$
t_1 to t_2	diode switching off	$V_o \cdot Q_r + \frac{1}{2} \cdot \frac{V_o^2 \cdot P_o}{V_i} \cdot \frac{C_{GD}}{I_{G(on)}}$
t_2 to t_3	MOSFET conducts	$\frac{P_o^2}{V_i \cdot V_o} \cdot R_{DSon} \cdot T$
t_3 to t_4	diode switching on	$\frac{1}{2} \cdot \frac{V_o^2 \cdot P_o}{V_i} \cdot \frac{C_{GD}}{I_{G(off)}} + \frac{1}{2} \cdot (V_{FR} - V_F) \cdot \frac{P_o}{V_o} \cdot t_{fr}$
t_0 to t_4	charge and discharge gate capacitance	$\int_0^T (V_G \cdot I_G) dt$

Table 1. Energy loss in distinct time periods

Better key characteristics at higher temperatures

Enables the use of:

- Smaller heat sink to reduce cost and space
- Low-rated MOSFET to reduce costs.

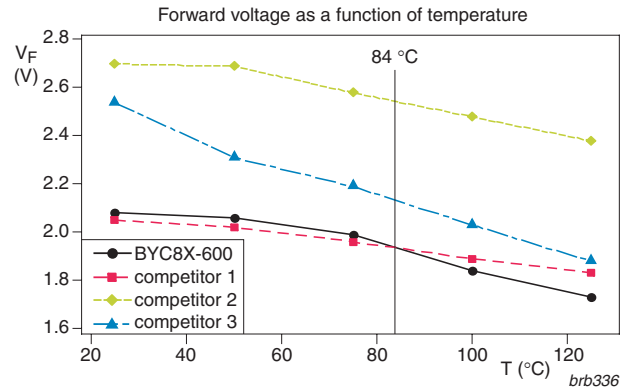

Fig 3. The V_F of NXP PFC diodes tends to drop faster as temperature rises

As the temperature rises, the V_F of NXP PFC diodes tends to drop faster than that of any other competitors. Figure 3 shows BYC8X-600 has the lowest V_F above 84 °C. In the application circuit, lower V_F will lead to a lower body temperature, thus improving the efficiency of the system

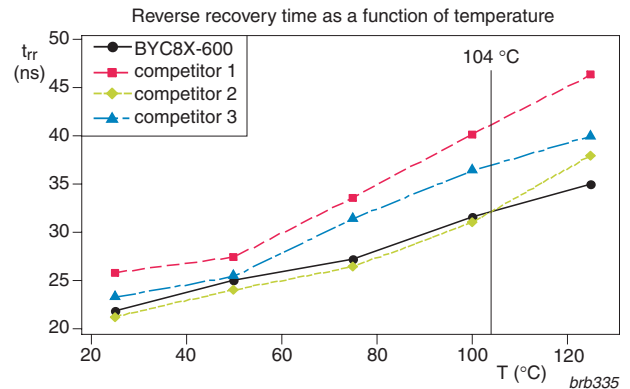

Fig 4. The t_{rr} of NXP PFC diodes tends to increase at a slower rate as temperature rises

The t_{rr} of NXP PFC diodes tends to increase more slowly as the temperature rises. Figure 4 shows BYC8X-600 has the shortest t_{rr} above 104 °C. In the application circuit, shorter t_{rr} will lead to lower temperature of the MOSFET, thus improving the efficiency of the system.

Best t_{rr} to V_F trade-off benefits

We already know that V_F and t_{rr} vary with temperature changes (see Figure 3 and 4) and conversely the temperature is influenced by the V_F and t_{rr} due to the energy loss (see Table 1). There is an equilibrium operating temperature at which point the V_F and t_{rr} are stable. Although NXP PFC diodes do not have the lowest V_F and shortest t_{rr} at normal ambient temperature (25 °C), they will reach the lowest equilibrium temperature because of the best V_F to t_{rr} trade-off (see Figure 5).

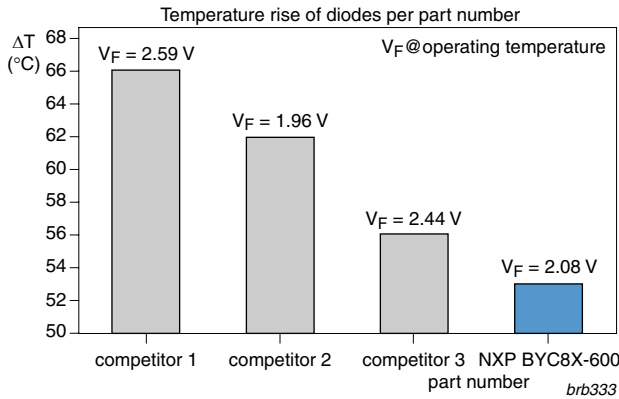

Fig 5. Example of the advantages of low V_F and V_{FR}

The energy loss equations (see Table 1) explain how BYC8X-600 has the lowest temperature rise. Energy loss in three periods contributes to the temperature rise of the diode.

V_F plays a key role in the diode conducting period (t_0 to t_1), t_{rr} plays a key role in the diode switch-off period (t_1 to t_2) and V_{FR} plays a key role in the diode switch-on period (t_3 to t_4). Since V_{FR} is more related to the design of the application circuit, it will not be discussed further here. The common P-N theory tells us the lower the V_F , the longer the t_{rr} and vice versa. There must be a trade-off point where V_F and t_{rr} benefit the system efficiency the most. Figure 6 shows NXP PFC diodes stand at that very point.

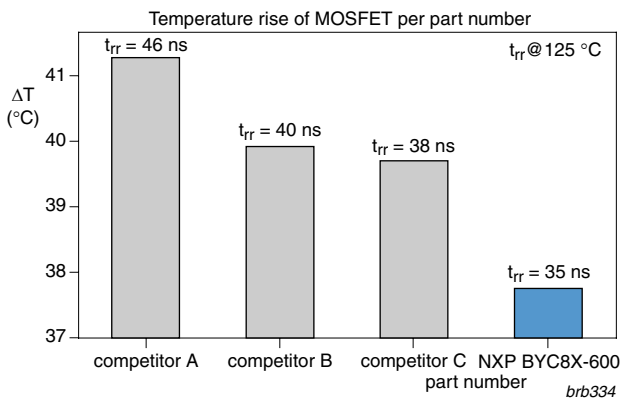

Fig 6. Temperature rise of MOSFET per part number

According to previous knowledge, it is very natural to see the results in Figure 6. The best trade-off of V_F to t_{rr} leads to the lowest operating temperature of the diode, conversely the lowest temperature of the diode results in the shortest t_{rr} . The shortest t_{rr} means the least energy dissipation through the MOSFET.

Selection for PFC diodes

There are two basic PFC operating modes: Discontinuous Conduction Mode (DCM) and Continuous Conduction Mode (CCM).

In DCM PFC diodes, focus must be on low V_F .

In CCM PFC diodes, focus must be on low Q_r (t_{rr}).

Application and design tips







The stored charge in the PFC diode that must be extracted during the reverse recovery phase (Q_r) causes dissipation in the MOSFET, especially in Continuous Conduction Mode. If the MOSFET runs too hot, it could mistakenly be replaced with a higher current type when in many circumstances it would be better to replace the PFC diode with a lower stored charge type.

The stored charge in a PFC diode approximately doubles with every 75 °C of temperature rise and this doubled charge will subsequently double the amount of related power loss in the MOSFET. Consequently, it is a good idea to keep the temperature of the PFC diode as low as possible e.g. by preventing a thermal path from the MOSFET (which may run hot) to the PFC diode.

Recommended products for SMPS applications

Application	CCM PFC diode	DCM PFC diode	ultrafast recovery diode
LCD TV	BYC5/BYC8/BYC10/BYC15 series (TO-220AC, TO-220F)	BYV25/BYV29 series (TO-220AC, TO-220F, I2PAK, D2PAK)	BYQ28X-200 (TO-220AB)
PDP TV		BYV25/BYV29/BYT79 series (TO-220F, D2PAK)	BYQ28E-200, BYQ30E-200 (TO-220AB)
desktop	BYC5/BYC8 series (TO-220AC, TO-220F)		BYQ28E-200, BYQ30E-200, BYV32E-200 (TO-220AB)
consumer adaptor		BYV25/BYV29/BYV34 series (TO-220AC, TO-220F, TO-220AB, I2PAK)	
lighting	BYC5/BYC8/BYC10/BYC15/BYC20 series (TO-220AC, TO-220F)	BYV25/BYV29 series (TO-220AC, TO-220F, I2PAK, D2PAK)	BYQ28/BYV32E series (TO-220AB, D2PAK)
file server	BYC8/BYC10/BYC15/BYC20 series (TO-220AC, TO-220F)	BYV29/BYT79/BYV410 series (TO-220AC, TO-220F, TO-220AB)	BYV32EB-200 (D2PAK)

Typical PFC power diode parameters

V_{RRM} [max] [V]	$I_{F(AV)}$ [max] [A]	V_F [typ] [V] @ 150 °C	$@I_F$ [A]	t_{rr} [typ] [ns] @ 25 °C	SOD59 (TO-220AC)	SOD113 (isolated 2-pin TO-220F)	SOT78 (TO-220AB)	SOT186A (isolated TO-220F)	SOT226 (I2PAK)	SOT428 (DPAK)
										
					15.5 x 10.0 x 4.3	15.5 x 10.0 x 4.3	15.6 x 10.0 x 4.4	15.5 x 10.0 x 4.3	11.0 x 10.0 x 4.3	6.0 x 6.6 x 2.3

Ultrafast diodes for DCM

600	5	0.97	5	50		BYV25X-600			BYV25G-600	BYV25D-600
	9	0.97	8	50	BYV29-600	BYV29X-600				
	15	1	15	50	BYT79-600	BYT79X-600				
	2 x 10	0.92	10	50			BYV34-600	BYV34X-600	BYV34G-600	







Enhanced ultrafast diodes for interleaved PFC and dual-mode DCM/CCM

600	9	1.16	10	30		BYV29FX-600				
	2 x 10	1.16	10	30			BYV410-600	BYV410X-600		

Hyperfast diodes for CCM

600	5	1.4	5	19	BYC5-600	BYC5X-600				
	8	1.4	8	19	BYC8-600	BYC8X-600				
	10	1.4	10	19	BYC10-600	BYC10X-600				
	15	1.4	15	19	BYC15-600	BYC15X-600				
	20	1.4	20	19	BYC20-600	BYC20X-600				

Typical ultrafast recovery rectifier diode parameters

V_{RRM} [max] [V]	$I_{F(AV)}$ [max] [A]	V_F [typ] [V] @ 150 °C	$@I_F$ [A]	t_{rr} [typ] [ns] @ 25 °C	SOD59 (TO-220AC)	SOD113 (isolated 2-pin TO-220F)	SOT78 (TO-220AB)	SOT186A (isolated TO-220F)	SOT223 (SC-73)	SOT404 (D2PAK)	SOT429 (TO-247)
											
					15.5 x 10.0 x 4.3	15.5 x 10.0 x 4.3	15.6 x 10.0 x 4.4	15.5 x 10.0 x 4.3	6.5 x 3.5 x 1.65	11.0 x 10.0 x 4.3	21.4 x 16.2 x 25.9
100	8	0.8	8	20	BYW29E-100						
	2 X 10	0.72	8	20			BYV32E-100				
150	2 X 0.75	0.5	0.5	10					BYV40E-150		
	8	0.8	8	20	BYW29E-150						
200	8	0.8	8	20	BYW29E-200	BYW29EX-200					
	2 X 5	0.8	5	15			BYQ28E-200	BYQ28X-200			
	14	0.83	14	20	BYV79E-200						
	2 X 8	0.84	8	20			BYQ30E-200				
	2 X 10	0.72	8	20			BYV32E-200			BYV32EB-200	
400	2 X 15	0.83	15	20							BYV72EW-200
	9	0.9	8	50	BYV29-400						
	2 X 15	0.95	15	50							BYV74W-400
600	8	1.07	8	60	BYR29-600	BYR29X-600					
800	8	1.07	8	60	BYR29-800	BYR29X-800					