

# NXP Near Field Communication (NFC) controller PN533

## Extensive proximity connectivity capabilities for USB-enabled devices

NXP Semiconductors' PN533 is a highly integrated transmission module for contactless communication at 13.56 MHz including a microcontroller. It is specially designed to provide USB-enabled devices with the most widely deployed contactless communication protocols.

### Key features

- ▶ Full peer-to-peer functionality
- ▶ Reader/ writer functionality compatible to ISO/IEC 14443 A&B, MIFARE, FeliCa and NFC Forum tag types (MIFARE UltraLight, Topaz, FeliCa, MIFARE DESFire)
- ▶ Card emulation functionality when connected to secure controller (P5CN072)
- ▶ Up to 10cm operating distance<sup>1)</sup>
- ▶ 80C51 core processor with embedded firmware
- ▶ USB host interface
- ▶ PN533 software is certified by Cetecom for eGovernment and by FIME for banking application
- ▶ NFC Sec for USB wireless and BT enabler support
- ▶ PC/SC driver WHQL pre-certified

### Key benefits

- ▶ Supports the most widely deployed contactless protocols with a single state-of-the-art chip
- ▶ Relieves the device host from contactless protocol real-time processing tasks and reduces device OS changes
- ▶ Device hosts connection flexibility thanks to the support of multiple interfaces besides USB

- ▶ Small footprint
- ▶ Worldwide support for design-in: antenna design, software
- ▶ Easy access to NFC technology, benefiting from NXP expertise and experience with major device manufacturers

### Target segments

Making it possible to create infrastructure devices that enable a revolutionary 'touch' experience in the computing, infrastructure, and business application segments.

- ▶ E-government and banking applications
- ▶ Ease the pairing of Bluetooth, Wi-Fi or WUSB devices
- ▶ Exchange objects such as vCards, digital rights
- ▶ Read a user-carried token or device for authentication before granting access to the device: logical access control, remote or proximity payment
- ▶ Read a user-carried token or device to authenticate before granting entry to a venue: physical access control

1) depending on antenna design and device integration

## Key applications

### Computing application

PC and peripheral

- On-line banking
- E-commerce
- E-government on-line access
- PC secure log-in

### Home reader application

- On-line banking
- E-commerce
- E-government on-line access

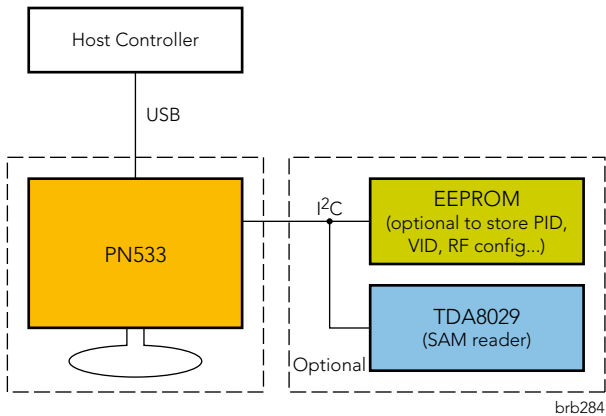

### Contactless terminal application

- Access control for building, transport gate
- Reader module for vending machine, kiosk

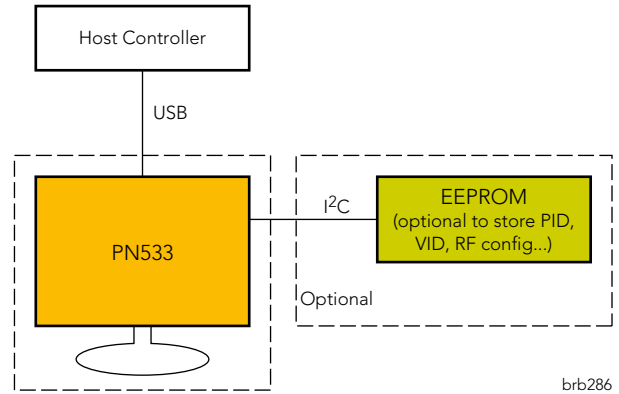

### Infrastructure (POS) application

- Contactless payment
- E-coupon management

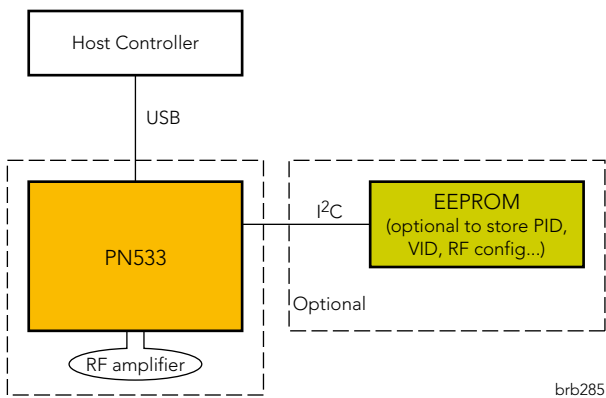

Key technical data		PN533
Contactless protocols	Peer-to-peer	Full ISO 18092 (up to 424 Kbits/s)
	Reader/writer	ISO 14443 A&B (up to 848 Kbits/s), MIFARE, FeliCa, NFC Forum tags
Host interface	USB 2.0 (full speed)	Yes
Extensions	I <sup>2</sup> C master interface	Available
	Connection to external EEPROM	Available
	Connection to Contact Reader	Available
Power characteristics	Supply voltage	2.5 V - 3.6 V
	USB bus power supply	4.2 V - 5.5 V
	Power down mode	12µA
	Typical RF active current	60mA
Temperature range		-25°C / +85°C

Ordering information			
Partnumber		PN5331B3HN/C270	
Sales description	Package	HVQFN40 (6mmx6mmx1,0mm)	
	Status	Available	
Ordering information	12NC	9352 878 68518	MOQ=4000
		9352 878 68551	MOQ=490
		9352 878 68557	MOQ=2450

Block diagram

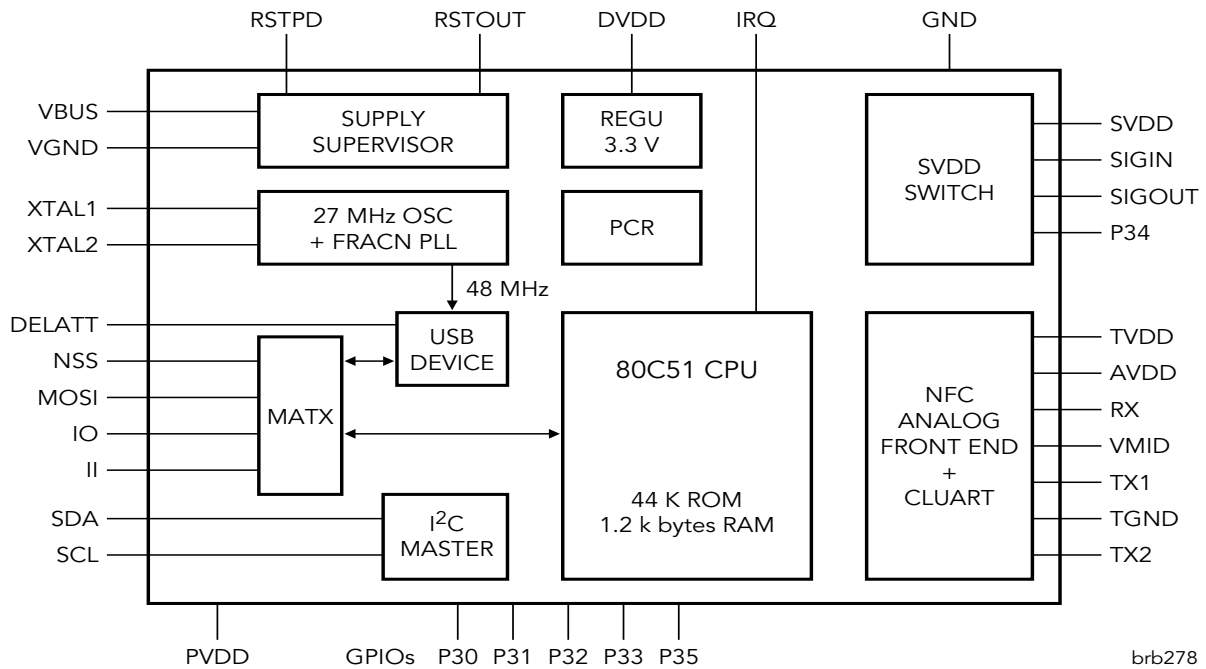

## Design-in kit

To support your product development and to enable easy access to NFC technology, NXP has prepared a design-in kit with all the necessary hardware, software and documentation:

- ▶ 12NC: 9352 865 87699
- ▶ 1 USB board
- ▶ 1 USB dongle demoboard (reference design)
- ▶ Cables and power supply
- ▶ Possibility to have contactless smart cards depending on export regulation restrictions
- ▶ Documentation: datasheet, user manual, application note
- ▶ Drivers, source code and examples (Windows, Linux)

NXP can also provide a NFC Forum protocol stack reference implementation.

## How to order documentation, samples, design-in kit

- ▶ A list with technical NFC documentation is available for each IC (<http://www.nxp.com/nfc>)
- ▶ NFC documentation can be requested by filling in the request form:  
[http://www.nxp.com/acrobat\\_download/other/identification/NFC\\_request\\_final.pdf](http://www.nxp.com/acrobat_download/other/identification/NFC_request_final.pdf)
- ▶ The samples and design-in kits can be ordered:
  - for NXP distributors via our portal: <https://extranet.nxp.com>
  - for customers a list of distributors is available at <http://www.nxp.com/nfc>

## Useful Links

NFC Forum specifications: <http://www.nfc-forum.org/specs/>

EMVco: <http://www.emvco.com>

MIFARE: <http://www.mifare.net>

CETECOM: <http://www.cetecom.de>

FIME: <http://www.fime.com>

MIFARE, FeliCa, Topaz are registered trademarks of NXP, Sony Corporation and Innovision Research and Technology plc. respectively

[www.nxp.com](http://www.nxp.com)



©2008 NXP B.V.

All rights reserved. Reproduction in whole or in part is prohibited without the prior written consent of the copyright owner. The information presented in this document does not form part of any quotation or contract, is believed to be accurate and reliable and may be changed without notice. No liability will be accepted by the publisher for any consequence of its use. Publication thereof does not convey nor imply any license under patent- or other industrial or intellectual property rights.

Date of release: November 2008

Document order number: 9397 750 16622

Printed in the Netherlands