



NXP Near Field Communication (NFC) for low cost portable electronic devices PN511 and PN512

Extensive proximity connectivity capabilities for portable electronic devices

NXP Semiconductors' **PN511** and **PN512** are highly integrated transceivers for contactless communication at 13.56MHz. They are designed to enable various types of low cost portable electronic devices with the most widely deployed contactless communication protocols.

Key features

- ▶ Reader/writer functionality compatible to ISO/IEC 14443 A (PN511), ISO/IEC 14443 A&B (PN512), MIFARE, FeliCa and NFC Forum tag types (Topaz, MIFARE UltraLight, FeliCa, MIFARE DESFire)
- ▶ Card emulation functionality when connected to a secure controller (P5CN072)
- ▶ Full peer-to-peer functionality (ISO/IEC 18092 NFC-IP1)
- ▶ Up to 10cm operating distance¹⁾
- ▶ Software source code for the host controller

Key benefits

- ▶ Supports the most widely deployed contactless protocols with a single state-of-the-art chip
- ▶ Device host connection flexibility thanks to the support of multiple interfaces
- ▶ Low power down current
- ▶ Small footprint
- ▶ Worldwide design-in support: antenna design, software
- ▶ Easy access to NFC technology, benefiting from NXP's expertise and experience with major device manufacturers

Key applications

- Enabling a wide variety of personal and infrastructure devices with a revolutionary 'touch' experience
- ▶ Highly integrated for medical applications
 - ▶ Remote or proximity payment such as POS terminals
 - ▶ Enter public transport network, offices or entertainment venues (physical access control, ticketing) by using an NFC-enabled handheld device
 - ▶ Easy access to web portal services by simply touching a smart poster containing the URL of the portal
 - ▶ Easy pairing of Bluetooth, Wi-Fi or WUSB devices
 - ▶ Exchange objects such as vCards or digital rights

1) depending on antenna design and device integration

Key applications

Reader/writer

Read/write NFC Forum tags such as MIFARE, MIFARE Ultralight, DESFire, FeliCa and Topaz

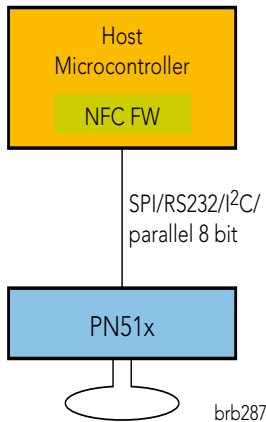

Card emulation

PN51x makes it possible to emulate:

- ▶ a MIFARE card to access public transport, stadium, office premises, etc.
- ▶ a MIFARE card to store loyalty program or pre-paid wallet
- ▶ an EMV payment card such as PayPass and VisaWave
- ▶ an active tag and change its content over the air (OTA)

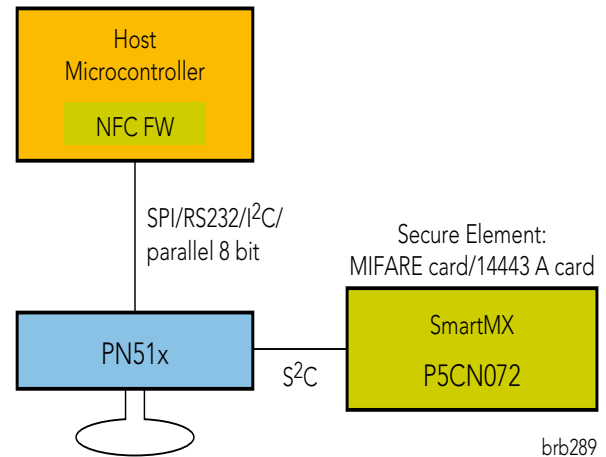

POS Terminal

Upgrade your reader with the NXP RF amplifier solution²⁾ to perform EMV (PayPass and VisaWave) compliant transactions

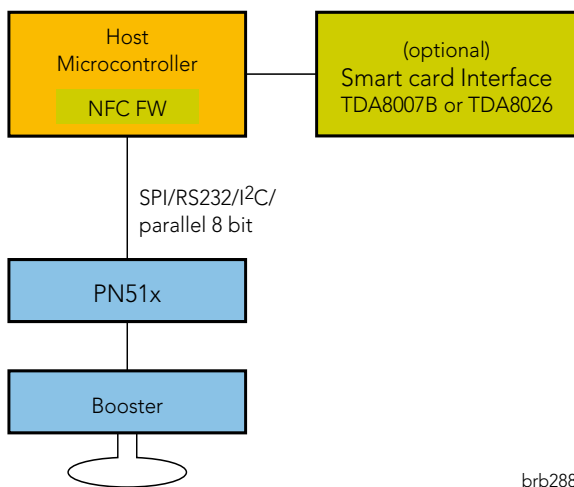

²⁾ Specific application note (RF Amplifier for NXP Contactless NFC Reader ICs) is available from <http://www.nxp.com/nfc>

Key technical data		PN511	PN512
Contactless protocols	Peer-to-peer	Full ISO 18092 (up to 424 Kbits/s)	Full ISO 18092 (up to 424 Kbits/s)
	Reader/writer	ISO 14443 A, MIFARE, FeliCa, NFC Forum tags	ISO 14443 A&B, MIFARE, FeliCa, NFC Forum tags
	Card emulation	ISO 14443 A, MIFARE, FeliCa	ISO 14443 A, MIFARE, FeliCa
Host interfaces	SPI	Up to 5 Mbit/s	Up to 5 Mbits/s
	Serial UART	Up to 1.228 Mbits/s	Up to 1.228 Mbits/s
	I ² C	400 Kbits/s - 3.4 Mbit/s	400 Kbits/s - 3.4 Mbits/s
	Secure element interface	S2C	S2C
Power characteristics	Supply voltage	2.5V - 3.6V	2.5V - 3.6V
	Power down mode	5µA	5µA
	Typical RF active current*)	60mA	60mA
Temperature range		-25°C/+85°C	-25°C/+85°C
Package		HVQFN32 (5mmx5mm)	HVQFN32 (5mmx5mm)
Software		Source code and examples (C, C++) for the host controller NFC Forum reference implementation can be provided	

*) depending on antenna design and modelling (see 1)

Ordering information					
Partnumber		PN5110A0HN1		PN5120A0HN1	
Sales description	Package Status	HVQFN32 Available		HVQFN32 Available	
Ordering information	12NC	9352 805 41118	MOQ=6000 (rail without dry pack)	9352 805 37118	MOQ=6000 (rail without dry pack)
		9352 805 41151	MOQ=490 (simple tray without dry pack)	9352 805 37151	MOQ=490 (simple tray without dry pack)
		9352 805 41157	MOQ=2450 (5 trays without dry pack)	9352 805 37157	MOQ=2450 (5 trays without dry pack)

Typical implementation example

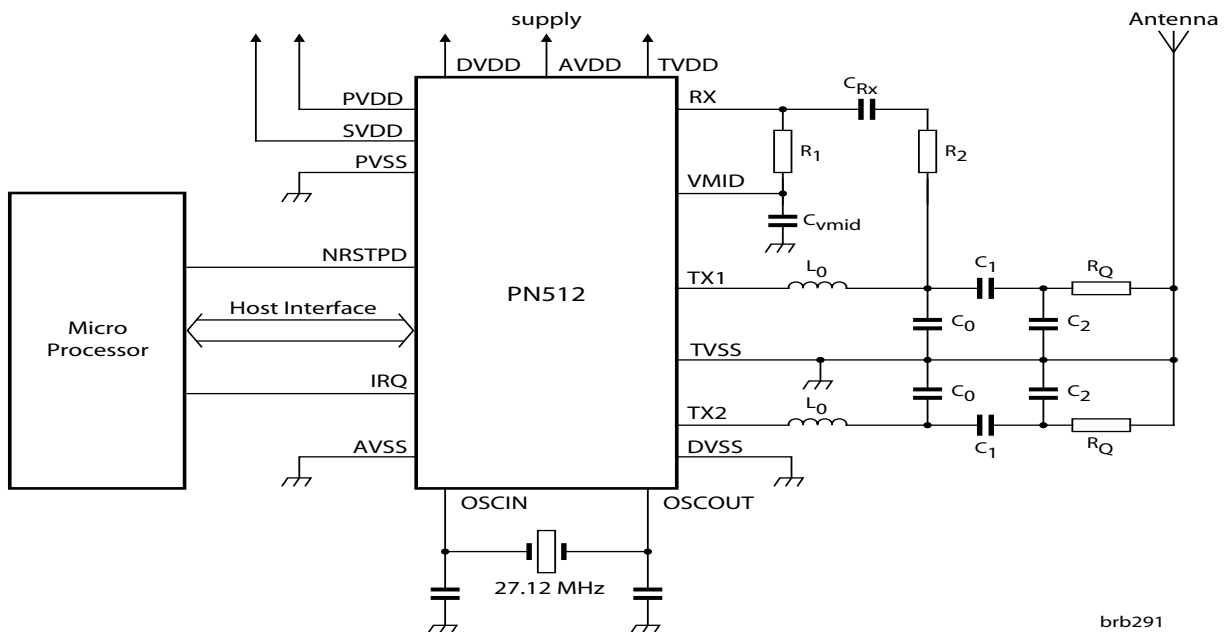

brb291

Design-in kit

To support your product development and to enable easy access to NFC technology, NXP has prepared a design-in kit with all the necessary hardware, software and documentation:

- ▶ 2 or 5 serial demo boards
- ▶ Cables and power supply
- ▶ Possibility to have contactless smart cards depending on export regulation restrictions
- ▶ Documentation: data sheet, software user manual, application notes
- ▶ Drivers, source code and examples (Windows, Linux)
- ▶ A daughter board with secure element (SmartMX) using S²C
- ▶ RF design guide

Useful Links

NFC Forum specifications: <http://www.nfc-forum.org/specs/>

EMVco: <http://www.emvco.com>

MIFARE: <http://www.mifare.net>

ISO: <http://www.iso.net>

FIME: <http://www.fime.net>

How to order documentation, samples, design-in kit

- ▶ A list with technical NFC documentation is available for each IC (<http://www.nxp.com/nfc>)
- ▶ NFC documentation can be requested by filling in the request form:
http://www.nxp.com/acrobat_download/other/identification/NFC_request_final.pdf
- ▶ The samples and design-in kits can be ordered:
 - for NXP distributors via our portal: <https://extranet.nxp.com>
 - for customers a list of NXP distributors is available at: <http://www.nxp.com/nfc>

MIFARE, FeliCa, Topaz are registered trademarks of NXP, Sony Corporation and Innovision Research and Technology plc. respectively

MIFARE.net

www.nxp.com



©2008 NXP B.V.

All rights reserved. Reproduction in whole or in part is prohibited without the prior written consent of the copyright owner. The information presented in this document does not form part of any quotation or contract, is believed to be accurate and reliable and may be changed without notice. No liability will be accepted by the publisher for any consequence of its use. Publication thereof does not convey nor imply any license under patent- or other industrial or intellectual property rights.

Date of release: October 2008

Document order number: 9397 750 16630

Printed in the Netherlands