

MF1 IC S50 06

Wafer specification addendum

Rev. 3.2 — 16 March 2007
075932

Product data sheet
PUBLIC

1. General description

The MF1 ICS 50 06 is a contactless smart card IC designed for card IC coils following the mifare card IC coil design guide and is qualified to work properly in NXP reader environment, which is built according to NXP specification.

This specification describes electrical, physical and dimensional properties of wafers.

2. Ordering information

Table 1. Ordering information

Type number	Package		
	Name	Description	Ordering Code
MF1ICS5006W/V5D		Die on sawn wafer	9352 798 43005

3. Mechanical specification

3.1 Wafer

- Diameter: 8"
- Thickness: $150\ \mu\text{m} \pm 15\ \mu\text{m}$
- Flatness: not applicable
- PGDW: 23775

3.2 Wafer backside

- Material: Si
- Treatment: ground and stress relieve
- Roughness: R_a max. $0.5\ \mu\text{m}$
 R_t max. $5\ \mu\text{m}$

3.3 Chip dimensions

- Chip size: $1.10 \times 1.03\ \text{mm}$
- Scribe lines: x-line: $86.4\ \mu\text{m}$
y-line: $86.4\ \mu\text{m}$

3.4 Passivation

- Type: sandwich structure
- Material: PSG / Nitride
- Thickness: 500 nm / 600 nm

3.5 Bond pads

- Pad size: $118 \times 118 \mu\text{m}^2$ (LA, LB)²
- Material: Al-Cu
- Thickness: 0.76 μm

Remark: Substrate is connected to VSS.

3.6 Fail die identification

All fail dies are inked according to electrical test results and additionally the results of mechanical / visual inspection.

Electronic wafer mapping covers the electrical test results and additionally the results of mechanical / visual inspection.

-
1. Passivation window: 90x90 μm
 2. Pads VSS and TESTIO are disconnected when wafer is sawn

4. Limiting values

Table 2. Limiting values [\[1\]](#)[\[2\]](#)[\[3\]](#)

In accordance with the Absolute Maximum Rating System (IEC 134)

Symbol	Parameter	Min	Max	Unit
I_{IN}	Input Current	-	30	mA
P_{tot}	Total power dissipation per package	-	200	mW
T_{stg}	Storage temperature range	-55	+125	°C
T_{amb}	Operating temperature	-25	70	°C
V_{ESD}	electrostatic discharge voltage LA-LB [4]	2		kV

[1] Stresses above one or more of the limiting values may cause permanent damage to the device

[2] These are stress ratings only. Operation of the device at these or any other conditions above those given in the Characteristics section of the specification is not implied

[3] Exposure to limiting values for extended periods may affect device reliability

[4] MIL Standard 883-C method 3015; Human body model: C = 100 pF, R = 1.5 kW

5. Characteristics

Table 3. Electrical characteristics [\[1\]](#)[\[2\]](#)[\[3\]](#)

Symbol	Parameter	Conditions	Min	Typ	Max	Unit
f_{IN}	input frequency		-	13.56	-	MHz
C_{IN}	Input capacitance	22 °C, Cp-D, (LCR meter HP4258) 13.56 MHz, 2 V	14.4	15.9	17.4	pF
t_W	EEPROM write time		-	2.9	-	ms
t_{RET}	EEPROM data retention		10			years
N_{WE}	EEPROM write endurance		10^5			cycles

[1] Stresses above one or more of the limiting values may cause permanent damage to the device

[2] These are stress ratings only. Operation of the device at these or any other conditions above those given in the Characteristics section of the specification is not implied

[3] Exposure to limiting values for extended periods may affect device reliability

6. Chip orientation and bond pad locations

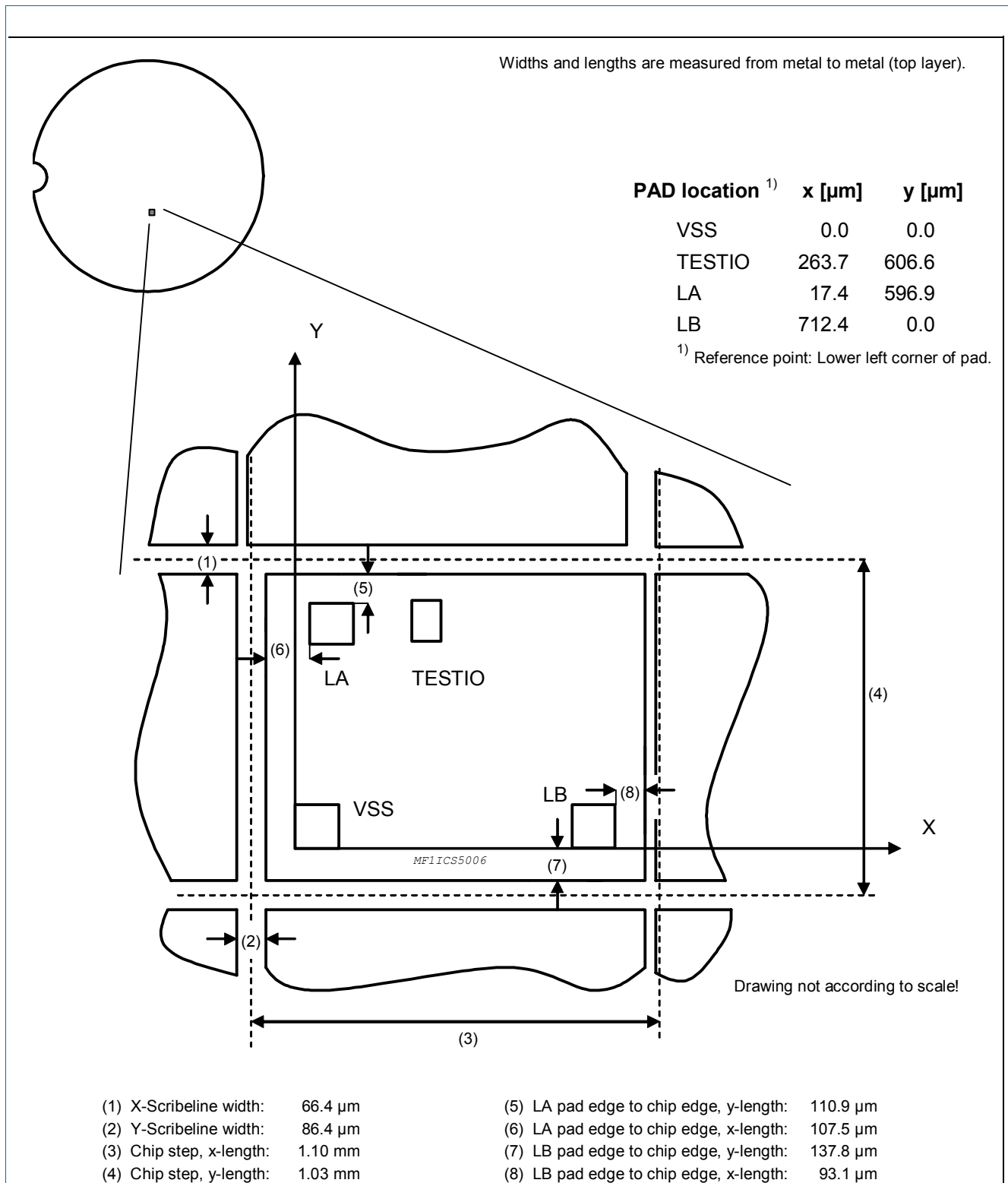

Fig 1. Chip orientation and bond pad locations

7. Application information

8. References

- [Data sheet “General specification for 8” wafers”](#)
- [Data sheet “Standard card IC MF1 IC S50 memory contents after test”](#)
- [Data sheet “Standard card IC MF1 IC S50 functional specification”](#)
- [Application note “Mifare, card IC coil design guide”](#)

9. Revision history

Table 4. Revision history

Document ID	Release date	Data sheet status	Change notice	Supersedes
075930	June 2005			
075931	February 2007	Product data sheet		3.0
075932	16 March 2007	Product data sheet	treatment information	Revision 3.1
Modifications:	<ul style="list-style-type: none">• The format of this data sheet has been redesigned to comply with the new identity guidelines of NXP Semiconductors.• Legal texts have been adapted to the new company name.			

10. Legal information

10.1 Data sheet status

Document status ^{[1][2]}	Product status ^[3]	Definition
Objective [short] data sheet	Development	This document contains data from the objective specification for product development.
Preliminary [short] data sheet	Qualification	This document contains data from the preliminary specification.
Product [short] data sheet	Production	This document contains the product specification.

[1] Please consult the most recently issued document before initiating or completing a design.

[2] The term 'short data sheet' is explained in section "Definitions".

[3] The product status of device(s) described in this document may have changed since this document was published and may differ in case of multiple devices. The latest product status information is available on the Internet at URL <http://www.nxp.com>.

10.2 Definitions

Draft — The document is a draft version only. The content is still under internal review and subject to formal approval, which may result in modifications or additions. NXP Semiconductors does not give any representations or warranties as to the accuracy or completeness of information included herein and shall have no liability for the consequences of use of such information.

Short data sheet — A short data sheet is an extract from a full data sheet with the same product type number(s) and title. A short data sheet is intended for quick reference only and should not be relied upon to contain detailed and full information. For detailed and full information see the relevant full data sheet, which is available on request via the local NXP Semiconductors sales office. In case of any inconsistency or conflict with the short data sheet, the full data sheet shall prevail.

10.3 Disclaimers

General — Information in this document is believed to be accurate and reliable. However, NXP Semiconductors does not give any representations or warranties, expressed or implied, as to the accuracy or completeness of such information and shall have no liability for the consequences of use of such information.

Right to make changes — NXP Semiconductors reserves the right to make changes to information published in this document, including without limitation specifications and product descriptions, at any time and without notice. This document supersedes and replaces all information supplied prior to the publication hereof.

Suitability for use — NXP Semiconductors products are not designed, authorized or warranted to be suitable for use in medical, military, aircraft, space or life support equipment, nor in applications where failure or malfunction of a NXP Semiconductors product can reasonably be expected to

result in personal injury, death or severe property or environmental damage. NXP Semiconductors accepts no liability for inclusion and/or use of NXP Semiconductors products in such equipment or applications and therefore such inclusion and/or use is at the customer's own risk.

Applications — Applications that are described herein for any of these products are for illustrative purposes only. NXP Semiconductors makes no representation or warranty that such applications will be suitable for the specified use without further testing or modification.

Limiting values — Stress above one or more limiting values (as defined in the Absolute Maximum Ratings System of IEC 60134) may cause permanent damage to the device. Limiting values are stress ratings only and operation of the device at these or any other conditions above those given in the Characteristics sections of this document is not implied. Exposure to limiting values for extended periods may affect device reliability.

Terms and conditions of sale — NXP Semiconductors products are sold subject to the general terms and conditions of commercial sale, as published at <http://www.nxp.com/profile/terms>, including those pertaining to warranty, intellectual property rights infringement and limitation of liability, unless explicitly otherwise agreed to in writing by NXP Semiconductors. In case of any inconsistency or conflict between information in this document and such terms and conditions, the latter will prevail.

No offer to sell or license — Nothing in this document may be interpreted or construed as an offer to sell products that is open for acceptance or the grant, conveyance or implication of any license under any copyrights, patents or other industrial or intellectual property rights.

10.4 Trademarks

Notice: All referenced brands, product names, service names and trademarks are the property of their respective owners.

Mifare — is a trademark of NXP B.V.

11. Contact information

For additional information, please visit: <http://www.nxp.com>

For sales office addresses, send an email to: salesaddresses@nxp.com

12. Tables

Table 1. Ordering information	1	Table 3. Electrical characteristics [1][2][3]	3
Table 2. Limiting values [1][2][3]	3	Table 4. Revision history	5

13. Figures

Fig 1. Chip orientation and bond pad locations	4
--	---

14. Contents

1	General description	1
2	Ordering information	1
3	Mechanical specification	1
3.1	Wafer	1
3.2	Wafer backside	1
3.3	Chip dimensions	1
3.4	Passivation	2
3.5	Bond pads	2
3.6	Fail die identification	2
4	Limiting values	3
5	Characteristics	3
6	Chip orientation and bond pad locations	4
7	Application information	5
8	References	5
9	Revision history	5
10	Legal information	6
10.1	Data sheet status	6
10.2	Definitions	6
10.3	Disclaimers	6
10.4	Trademarks	6
11	Contact information	6
12	Tables	7
13	Figures	7
14	Contents	7

Please be aware that important notices concerning this document and the product(s) described herein, have been included in section 'Legal information'.



© NXP B.V. 2007.

All rights reserved.

For more information, please visit: <http://www.nxp.com>

For sales office addresses, please send an email to: salesaddresses@nxp.com

Date of release: 16 March 2007

Document identifier: 075932