

AN10739

Discrete LED driver

Rev. 01 — 11 February 2009

Application note

Document information

Info	Content
Keywords	LED, constant current source, buck converter
Abstract	This application note describes a 300 mA discrete LED driver, based on a buck-converter principle, with a cycle-by-cycle current control. It includes a proposal for a BOM and layout of a low cost, low component count solution.

Revision history

Rev	Date	Description
01	20090211	Initial version

Contact information

For more information, please visit: <http://www.nxp.com>

For sales office addresses, please send an email to: salesaddresses@nxp.com

1. Introduction

This application note describes a 300 mA discrete LED driver, based on a buck-converter principle with an efficiency of 80 to 90 %. It includes a proposal for a BOM and layout leading to a low cost, low component count solution to drive a single LED or a string of LEDs connected in series.

The choice of the discrete parts is discussed with respect to NXP's bipolar low V_{CEsat} (BISS) and ultra low V_F MEGA Schottky technologies, i.e. the PBSSxxx series and the PMEGxxx series.

Key applications for the driver are lighting applications, where constant LED brightness, high efficiency and low cost are important features. For example automotive lighting applications require that general illumination and signage should not consume too much power when the motor is not running. The input voltage of +6 V to +18 V supports automotive requirements, too.

Besides, battery driven handhelds like flash lights or head lamps will benefit from the topology and efficiency the driver delivers.

2. Operating principle

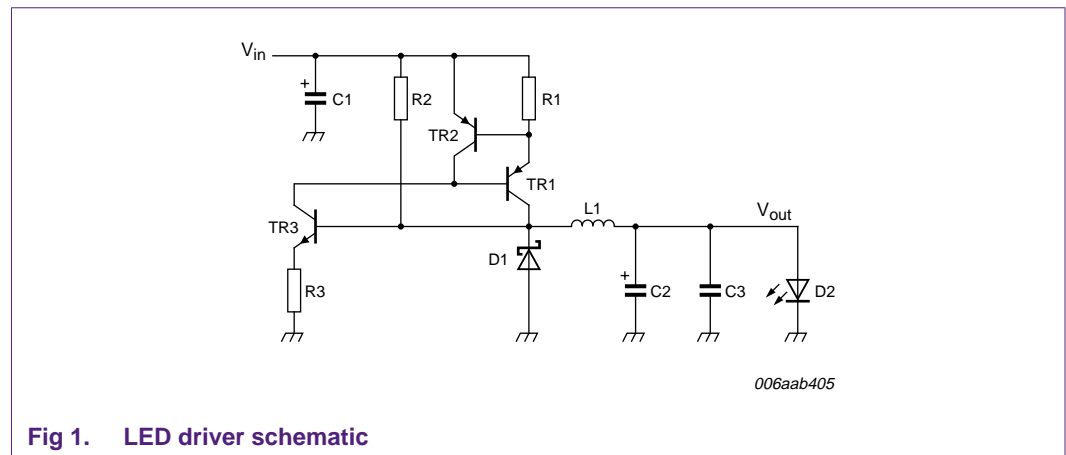

Fig 1. LED driver schematic

2.1 Basic operating principle

The 300 mA discrete LED driver is based on the buck-converter principle with a cycle-by-cycle current control. The input peak current is set by resistor R1 and by modifying R1, the current can easily be set to lower or higher values, i. e. designing a driver from 20 mA to 1 A.

When applying supply voltage V_{in} , TR3 is switched on, providing the base current for the PNP transistor TR1 and switching it on. With diode D1 reversed biased, current starts to flow through inductor L1 and LED D2.

The coil equation described by [Equation 1](#) shows that a desired rise or fall of the inductor current requires a certain voltage step applied to the inductor, with the factor of proportionality L, called the self-inductance of the coil:

$$v_L(t) = L \times \frac{\Delta i_L(t)}{\Delta t} \tag{1}$$

With an LED as load and a constant V_{in} the result is a linearly increasing input current, as depicted in [Figure 2](#):

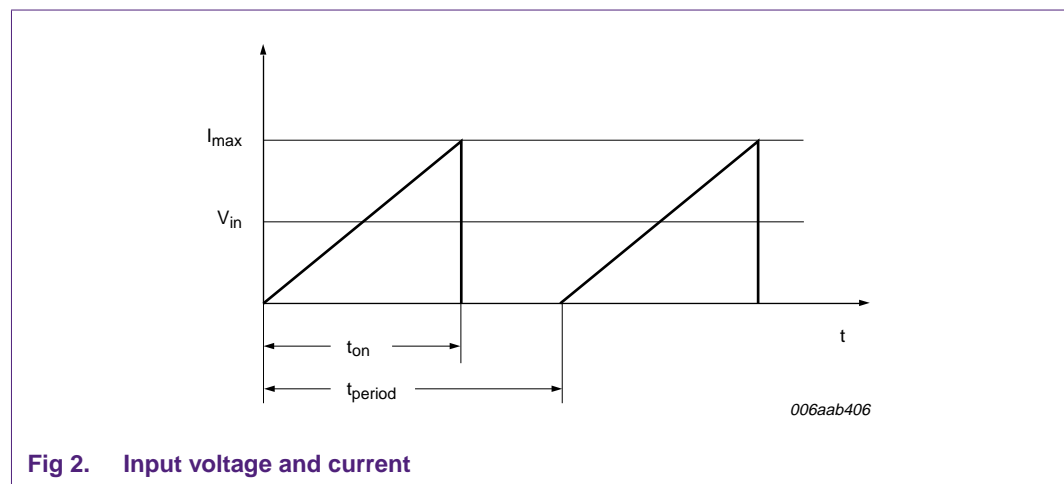

Fig 2. Input voltage and current

As the collector current of TR1 increases, the voltage drop at the current sense resistor R1 increases, too. When the voltage drop reaches TR2s base-emitter turn-on voltage $V_{BE(on)}$ of about 0.65 V, TR2 switches on and pulls the base of TR1 to the supply voltage, i. e. turns TR1 off.

The value of R1, therefore, sets the maximum input current in the application, which flows through R1, TR1 and the inductor L1.

When switching TR1 off, its collector current almost immediately drops back to zero. The inductor, however, cannot change its current suddenly, according to $\Delta I/\Delta t = V/L$. The current will decrease but continues to flow in the same direction, with diode D1 now conducting.

As D1 is forward biased, the voltage over L1 reverses when TR1 is switched off. The voltage level at the cathode is $-V_F$ of the Schottky diode, as long as there is energy stored in the inductor.

Solving the inductor equation for this case and taking $i_L(0) = I_{max}$ as boundary condition leads to:

$$i_L(t) = \frac{v_L(t) \times t}{L} + I_{max} = \frac{-V_{out} \times t}{L} + I_{max} \tag{2}$$

The current is decreasing until it reaches zero, depicted in [Figure 3](#).

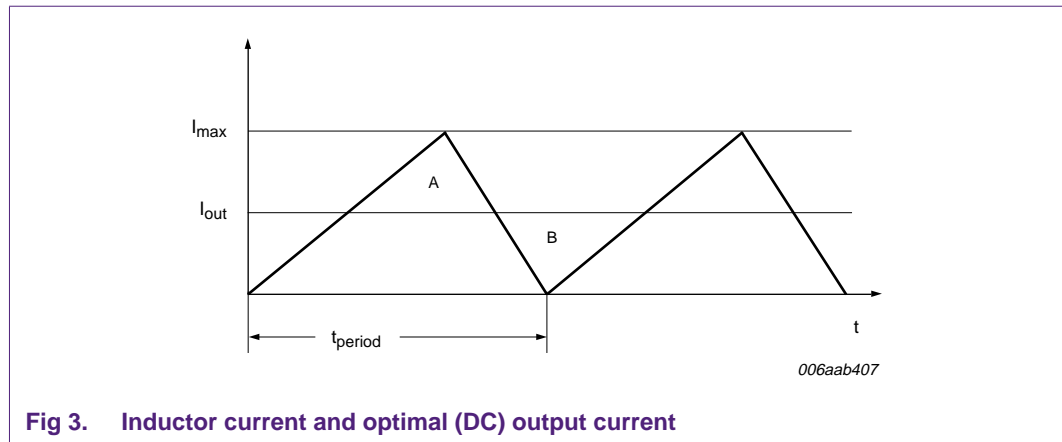

Fig 3. Inductor current and optimal (DC) output current

When all the energy that was stored in the inductor is delivered to the output, D1 becomes reversed biased again and the procedure is restarted.

2.2 Current, current ripple and switching frequency

The slope of the current is set by the voltage step across the inductor, and for a fixed input voltage this voltage step is constant because the voltage drop across the LED is nearly independent from its current.

The constant voltage step at the inductor leads to a linearly increasing current (remember: $\Delta I/\Delta t = V/L$) flowing through the inductor and the LED - neglecting losses and other parasitics effects.

When no output capacitors are used, the output current is exactly the coil current and the ripple height would be $\pm 50\%$ (see [Figure 3](#)).

To get smaller output ripples, the capacitor C2 is added, acting as a charge storage device and smoothing the sawtooth ripple. The value of the capacitor must be chosen according to LED current and flicker requirements of the specific application, the larger the capacitor, the less the ripple.

The most important design value for the LED driver is the average output current, which is half the peak current of the coil set by R1 ($I_{\max} = V_{BE(TR2)}/R1$).

Looking at [Equation 1](#) the energy absorption at the circuit input for one period can be determined as:

$$W_{in} = \frac{1}{2} \times I_{max} \times V_{in} \times t_{on} \quad (3)$$

The energy provided to the LED is:

$$W_{out} = I_{out} \times V_F \times (t_{on} + t_{off}) \quad (4)$$

I_{out} is the desired DC LED current.

t_{on} and t_{off} are the turn-on time and the turn-off time of TR1, and the rise time t_r and the fall time t_f of the coil current, respectively. Their values can be calculated using the two solutions of the coil equation derived above. During t_{on} the coil current needs to rise from 0 to I_{max} . Thus, using [Equation 2](#), the turn-on time can be calculated to:

$$t_{on} = I_{max} \times \frac{L}{V_{in} - V_{out}} \quad (5)$$

The time the current needs to drop back to 0 A is:

$$t_{off} = I_{max} \times \frac{L}{V_{out}} \quad (6)$$

Pasting [Equation 5](#) and [Equation 6](#) into [Equation 3](#) and [Equation 4](#) and applying the power conservation law yields (assuming no losses in the circuit):

$$W_{out} = W_{in} \Rightarrow I_{out} = \frac{1}{2} \times I_{max} \quad (7)$$

t_{on} and t_{off} determine the switching frequency of the circuit:

$$f = \frac{1}{t_{on} + t_{off}} = \frac{V_{in} - V_{out}}{L \times I_{max}} \times \frac{V_{out}}{V_{in}} \quad (8)$$

3. Dimensioning and choice of discrete parts

The choice of the discrete parts on one hand is dependent on the input requirements like input voltage range, LED current and switching frequencies. On the other hand, the performance of the devices like their on-state losses, switching losses or the power dissipation capabilities of a specific package influence the efficiency and the costs of the circuit.

3.1 Inductor L1, Transistor TR1 and Schottky diode D1

3.1.1 Inductor L1

The switching frequency of the circuit is determined by the input voltage V_{in} , the LED forward voltage V_F , the peak current I_{max} , and the inductor value L (see [Equation 8](#)).

With given input conditions one can calculate the resulting switching frequency for different values of L to get a guideline for the choice of the inductor. In general, L shall be as small as possible to reduce costs and package size of the device.

Smaller inductors usually have a smaller DC resistance, too, leading to higher efficiency of the whole circuit. The minimum coil saturation current rating should be 1.2 times the peak current.

Alternatively, one can specify a maximum switching frequency of the application to derive the required inductor, using [Equation 8](#). For the example below, f_{max} was set to 100 kHz, which is an appropriate value for a bipolar switch and also noise immunity.

Example:

For $f_{max} = 100 \text{ kHz}$, $I_{max} = 0.6 \text{ A}$, $V_{in(max)} = 18 \text{ V}$, $V_F = 3.2 \text{ V}$

$$L = \frac{18V - (3,2V)}{100kHz \times 0,6A} \times \frac{3,2V}{18V} = 43,85\mu H$$

Taking 47 μH will result in a maximum switching frequency of < 100 kHz for $V_{in} = 18 \text{ V}$.

3.1.2 Transistor TR1

A bipolar transistor in a small SMD package shall be used for the switch as it offers an excellent performance-cost ratio for this application. The final choice of the device is dependent on the required performance. I_C and V_{CE0} are given by the input conditions but also the losses of the device, i. e. P_{tot} , during operation are important. The main parameters contributing to the losses are the saturation voltage V_{CEsat} and the power loss during the fall time t_f during turn-off.

The best choice to keep the on-state losses low, is using a low V_{CEsat} (BISS) transistor whereas BV_{CE0} shall be at least $1.2 \times V_{in(max)}$, and $I_{C(max,DC)}$ shall be at least $1.2 \times I_{max}$.

Besides the on-state losses, switching times are an important factor for the efficiency whereas the main contributor is the fall time. Losses during the rise time are nearly zero as with an inductive load the collector current rises slowly.

PBSS5220T is a good choice for a 300 mA driver with an input voltage from +6 V to +18 V.

The device is a 2 A, 20 V bipolar low V_{CEsat} (BISS) transistor, with a typical V_{CEsat} of 70 mV at $I_C = 600$ mA and reasonable switching times. It comes in the very cost-efficient SOT23 package, with a P_{tot} of 250 mW on standard footprint.

To assure saturation for TR1 - in order to benefit from the low V_{CEsat} technology - R3 must be chosen in a way that with $I_{C,TR3}$ (which equals $I_{B,TR1}$) an I_C/I_B ratio of about 30 is adjusted.

For a maximum TR1 collector current of 600 mA, I_B shall be tuned to 20 mA, with $R3 = 510 \Omega$.

For the resulting $I_C/I_B = 30$, there is no V_{CEsat} curve in the set of curves shown below for PBSS5220T. To get an idea of the power dissipation during t_{on} , the value for an $I_C/I_B = 50$ is taken, which will be at least equal or worse.

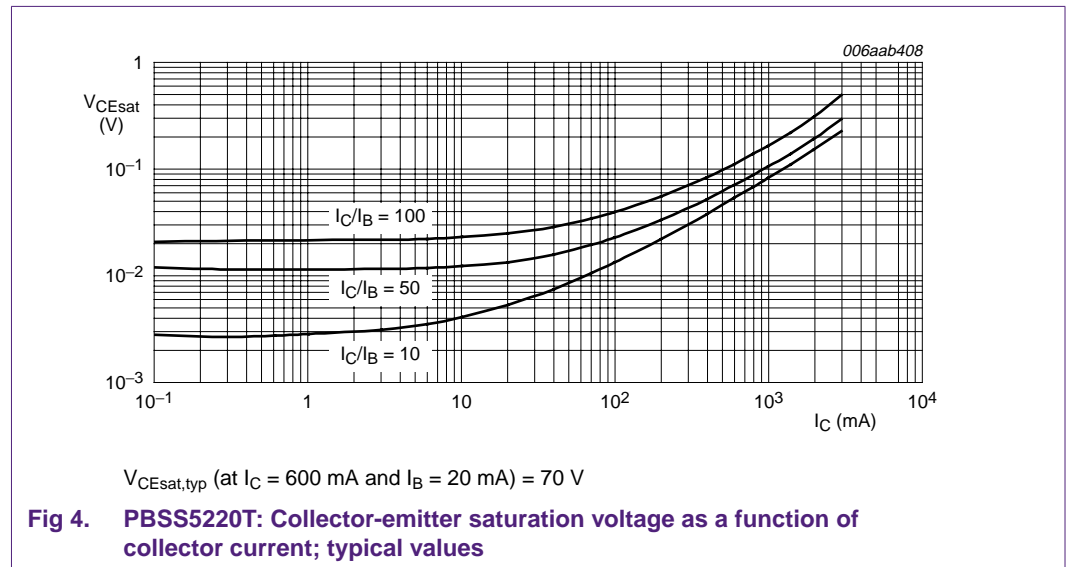

3.1.3 Schottky diode D1

A Schottky diode is chosen for the 'catch diode', to provide a current path for the LED current during t_{off} .

NXP's MEGA Schottky PMEG series offers an ultra low forward voltage V_F , resulting in reduced heat generation during operation and an increased efficiency.

PMEG2010EJ is proposed for a 300 mA LED driver, which is a 20 V, 1 A MEGA Schottky diode in the SOD323F (SC-90) package. It offers a P_{tot} of 360 mW on standard footprint with a V_F of typically 340 mV at 0.6 A DC current, whereas the SOD323F (SC-90) package is a cost-efficient solution, which can not only serve for the 300 mA LED driver but also for modifications up to higher output currents.

4. Demo-Board and measurements

To demonstrate the performance of the application discussed above, a demonstrator was realized on a 16.5 mm × 49.5 mm PCB, with the BOM proposed (see [Section 4.1](#)).

Input requirements were an input voltage range from +6 V to +18 V, low LED current ripple and a maximum switching frequency < 100 kHz.

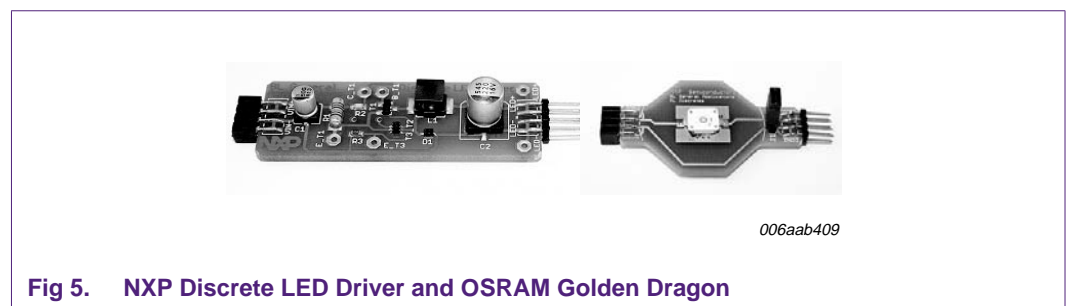

4.1 BOM proposal: 300 mA driver

Table 1. BOM proposal 350 mA LED current

BOM part	Proposal
R1	1.2 Ω (2010), 1 W resistor
R2	10 kΩ (0603)
R3	510 Ω (0603)
C1	1 μF
C2	220 μF
C3	not connected
L1	47 μH, LQH55D series from Murata
D1	PMEG2010EJ; 20 V, 1 A Schottky diode (SOD323F/SC-90), NXP
D2	1 A LED; OSRAM Golden Dragon LW W5SM
TR1	PBSS5220T; 20 V, 2 A PNP low V_{CEsat} (BISS) transistor (SOT23), NXP
TR2, TR3	BC847BPN; NPN/PNP general-purpose double transistor (SOT363), NXP

4.1.1 Measurements

Measurements have been performed on the final layout regarding efficiency and switching frequencies.

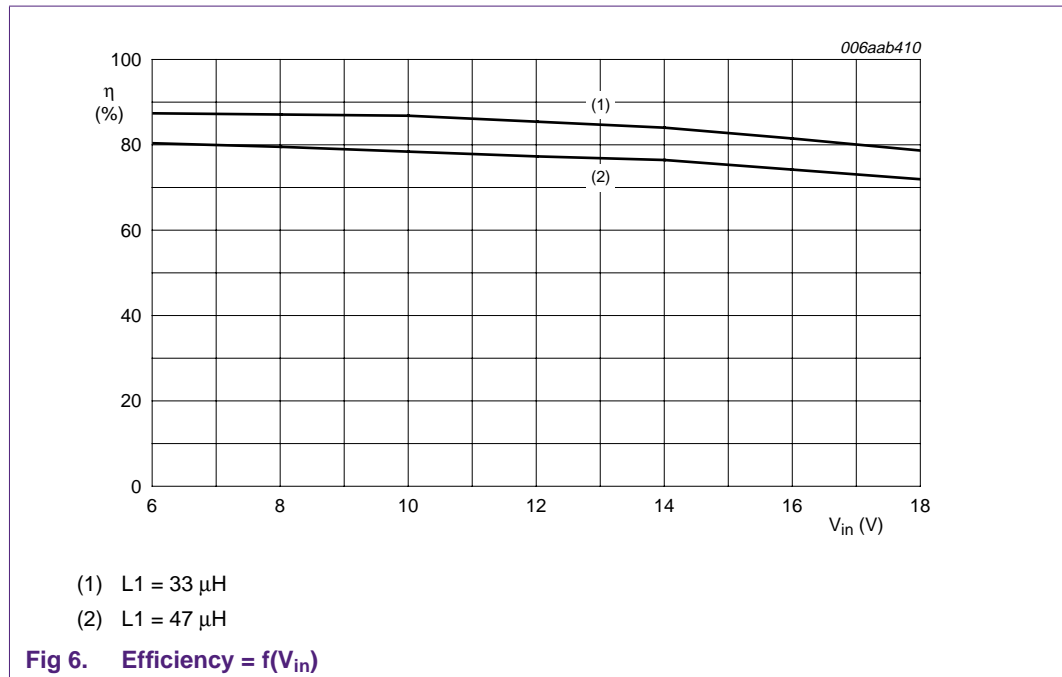

The efficiency P_{in}/P_{out} of the board as shown with $L1 = 47 \mu H$ is about 80 % for a supply voltage range from 9 V to 12 V.

Choosing lower inductor values would result in a higher efficiency, as usually a smaller inductor comes with a lower DC resistance as well as lower inductor core losses.

But, the smaller the inductor, the higher the maximum switching frequency of the application.

Using 33 μH instead of 47 μH would increase the efficiency to > 85 %. With 18 V input voltage, the switching frequency would be about 120 kHz (see [Equation 8](#)), and the resulting effects on increased switching losses and noise immunity may become an issue for certain application areas. However, the layout should be able to handle a minimum value of L1 of 22 μH .

Using an LED string instead of a single LED would result in an increased efficiency, too, as the ratio between input and output voltage in that case would be beneficial for a buck converter.

As with increasing input voltage also the switching frequency increases, the efficiency drops because of higher switching losses in the discrete devices.

The increase of frequency is shown below as a comparison between the theoretical values using [Equation 8](#) and a real measurement.

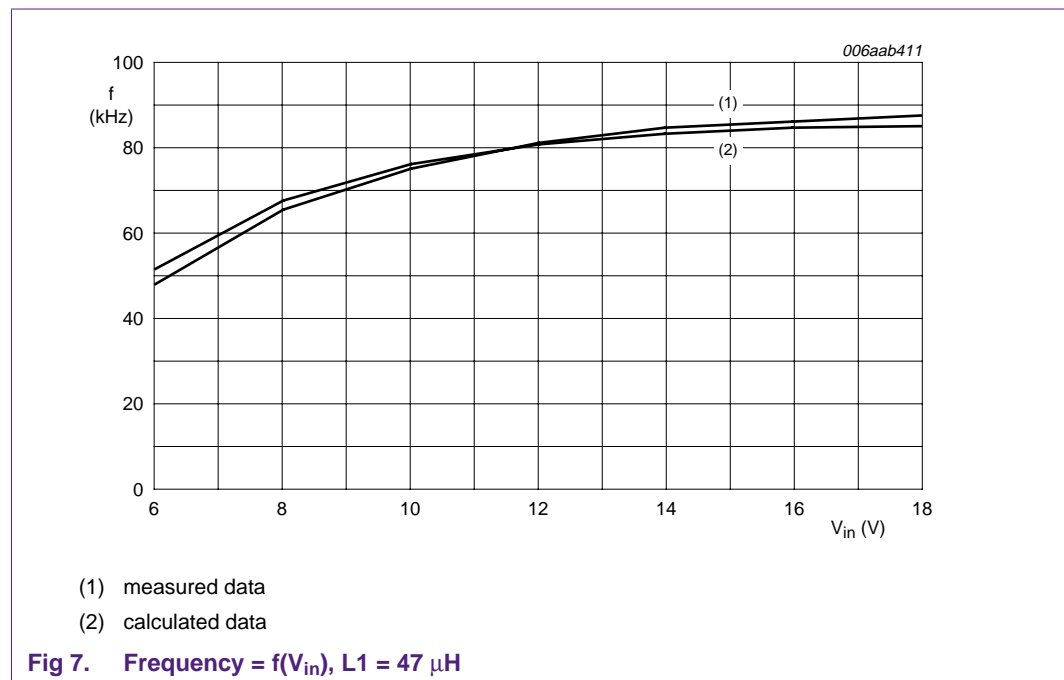

5. Conclusion

- Highly efficient constant current LED driver using a switching power conversion solution based on a buck-converter principle, supported by NXP's low V_{CEsat} BISS and MEGA Schottky technologies
- Applicable for a wide input voltage range from +6 V to +18 V
- Applicable for a wide range of ambient temperatures due to low power dissipation / low heat generation of the driver
- Low cost, low component count solution
- Modifiable for a wide range of output currents from 300 mA up to 1 A

6. Legal information

6.1 Definitions

Draft — The document is a draft version only. The content is still under internal review and subject to formal approval, which may result in modifications or additions. NXP Semiconductors does not give any representations or warranties as to the accuracy or completeness of information included herein and shall have no liability for the consequences of use of such information.

6.2 Disclaimers

General — Information in this document is believed to be accurate and reliable. However, NXP Semiconductors does not give any representations or warranties, expressed or implied, as to the accuracy or completeness of such information and shall have no liability for the consequences of use of such information.

Right to make changes — NXP Semiconductors reserves the right to make changes to information published in this document, including without limitation specifications and product descriptions, at any time and without notice. This document supersedes and replaces all information supplied prior to the publication hereof.

Suitability for use — NXP Semiconductors products are not designed, authorized or warranted to be suitable for use in medical, military, aircraft, space or life support equipment, nor in applications where failure or malfunction of an NXP Semiconductors product can reasonably be expected to result in personal injury, death or severe property or environmental damage. NXP Semiconductors accepts no liability for inclusion and/or use of NXP Semiconductors products in such equipment or applications and therefore such inclusion and/or use is at the customer's own risk.

Applications — Applications that are described herein for any of these products are for illustrative purposes only. NXP Semiconductors makes no representation or warranty that such applications will be suitable for the specified use without further testing or modification.

6.3 Trademarks

Notice: All referenced brands, product names, service names and trademarks are the property of their respective owners.

7. Contents

1 Introduction 3

2 Operating principle 3

2.1 Basic operating principle. 3

2.2 Current, current ripple and switching frequency 5

3 Dimensioning and choice of discrete parts .. 7

3.1 Inductor L1, Transistor TR1 and Schottky diode D1 7

3.1.1 Inductor L1 7

3.1.2 Transistor TR1 7

3.1.3 Schottky diode D1. 9

4 Demo-Board and measurements 9

4.1 BOM proposal: 300 mA driver 10

4.1.1 Measurements 10

5 Conclusion 12

6 Legal information..... 13

6.1 Definitions 13

6.2 Disclaimers 13

6.3 Trademarks 13

7 Contents 14

Please be aware that important notices concerning this document and the product(s) described herein, have been included in section 'Legal information'.



© NXP B.V. 2009.

All rights reserved.

For more information, please visit: <http://www.nxp.com>
 For sales office addresses, please send an email to: salesaddresses@nxp.com

Date of release: 11 February 2009
 Document identifier: AN10739_1