

ADC1410S065/080/105/125

Single 14-bit ADC 65, 80, 105 or 125 Msps
CMOS or LVDS DDR digital outputs

Rev. 02 — 4 June 2009

Objective data sheet

1. General description

The ADC1410S is a single channel 14-bit Analog-to-Digital Converter (ADC) optimized for high dynamic performances and low power consumption at sample rates up to 125 Msps. Pipelined architecture and output error correction ensure the ADC1410S is accurate enough to guarantee zero missing codes over the entire operating range. Supplied from a single 3 V source, it can handle output logic levels from 1.8 V to 3.3 V in CMOS mode, thanks to a separate digital output supply. It supports the LVDS (Low Voltage Differential Signalling) DDR (Double Data Rate) output standard. An integrated SPI (Serial Peripheral Interface) allows the user to easily configure the ADC. The device also includes a programmable gain amplifier with a flexible input voltage range. With excellent dynamic performance from the baseband to input frequencies of 170 MHz or more, the ADC1410S is ideal for use in communications, imaging and medical applications.

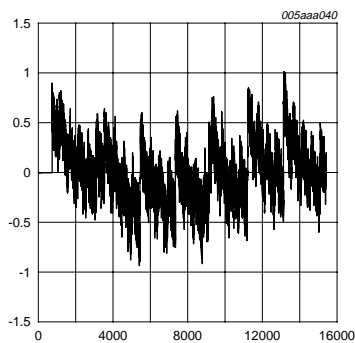

Fig 1. Integral Non-Linearity (INL)

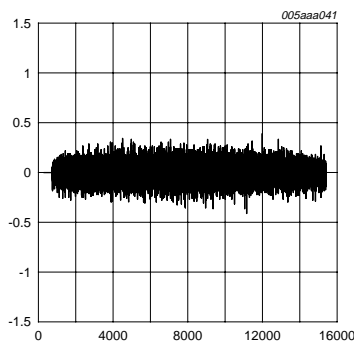

Fig 2. Differential Non-Linearity (DNL)

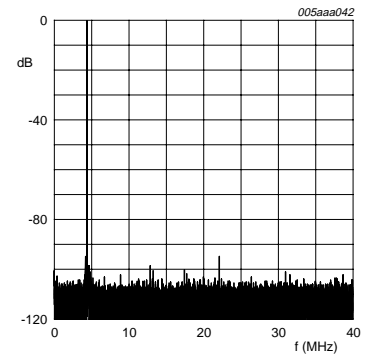

Fig 3. Output spectrum: -1 dBFS, 80 Msps, $f_i = 4.43$ MHz

2. Features

- SNR, 73 dB
- SFDR, 90 dBc
- Sample rate up to 125 Msps
- 14-bit pipelined ADC core
- Single 3 V supply
- Flexible input voltage range: 1 V to 2 V p-p with 6 dB programmable fine gain
- CMOS or LVDS DDR digital outputs
- INL ± 1 LSB, DNL ± 0.5 LSB (typical)
- Input bandwidth, 600 MHz
- Power dissipation, 387 at 80 Msps
- SPI Interface
- Duty cycle stabilizer
- Fast OTR detection
- Offset binary, 2's complement, gray code
- Power-down and Sleep modes
- HVQFN40 package

3. Applications

- Wireless and wired broadband communications
- Spectral analysis
- Ultrasound equipment
- Portable instrumentation
- Imaging systems

4. Ordering information

Table 1. Ordering information

Type number	f _s (Msps)	Package		Version
		Name	Description	
ADC1410S125HN/C1	125	HVQFN40	plastic thermal enhanced very thin quad flat package; no leads; 40 terminals; body 6 × 6 × 0.85 mm	SOT618-1
ADC1410S105HN/C1	105	HVQFN40	plastic thermal enhanced very thin quad flat package; no leads; 40 terminals; body 6 × 6 × 0.85 mm	SOT618-1
ADC1410S080HN/C1	80	HVQFN40	plastic thermal enhanced very thin quad flat package; no leads; 40 terminals; body 6 × 6 × 0.85 mm	SOT618-1
ADC1410S065HN/C1	65	HVQFN40	plastic thermal enhanced very thin quad flat package; no leads; 40 terminals; body 6 × 6 × 0.85 mm	SOT618-1

5. Block diagram

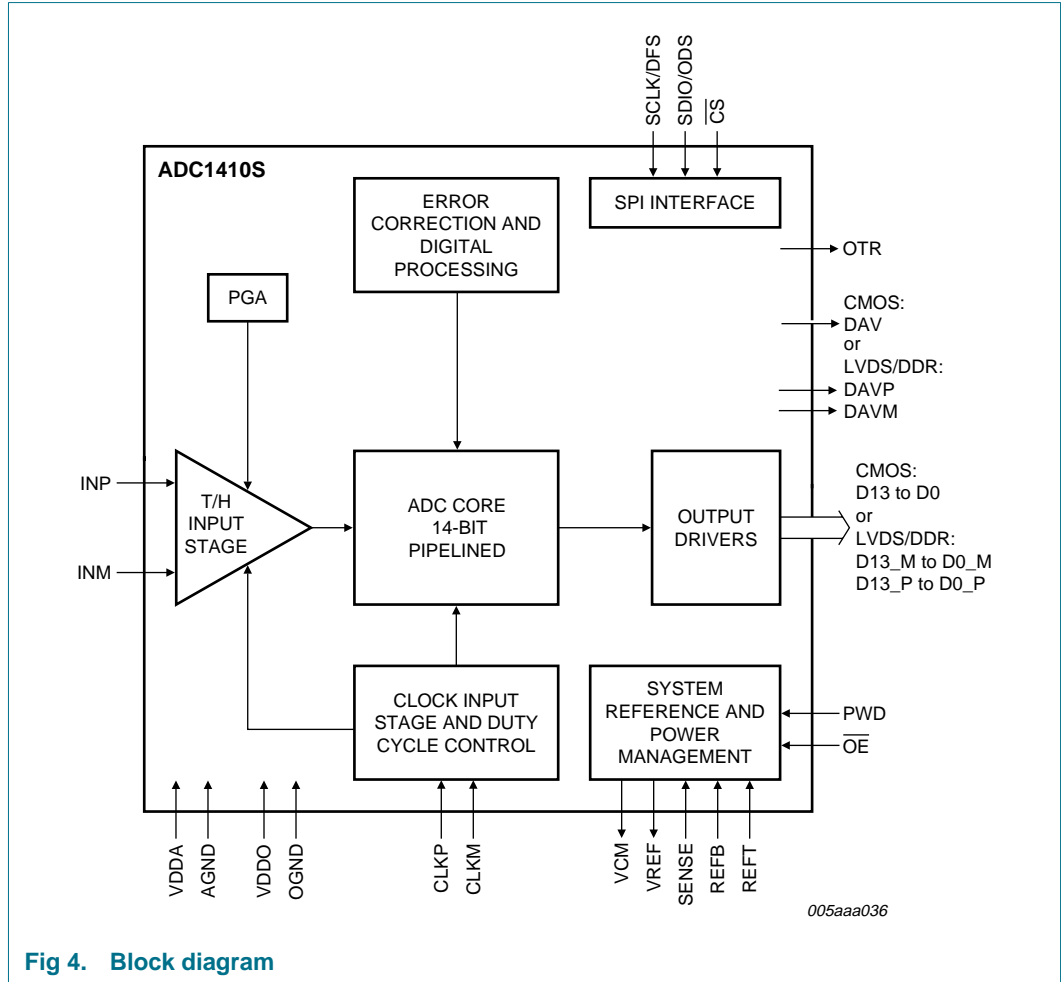

Fig 4. Block diagram

6. Pinning information

6.1 Pinning

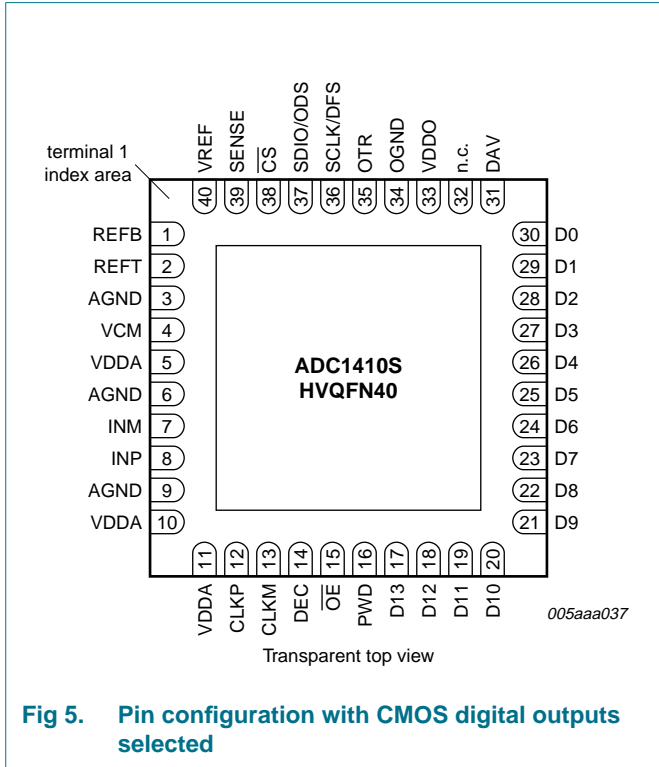

Fig 5. Pin configuration with CMOS digital outputs selected

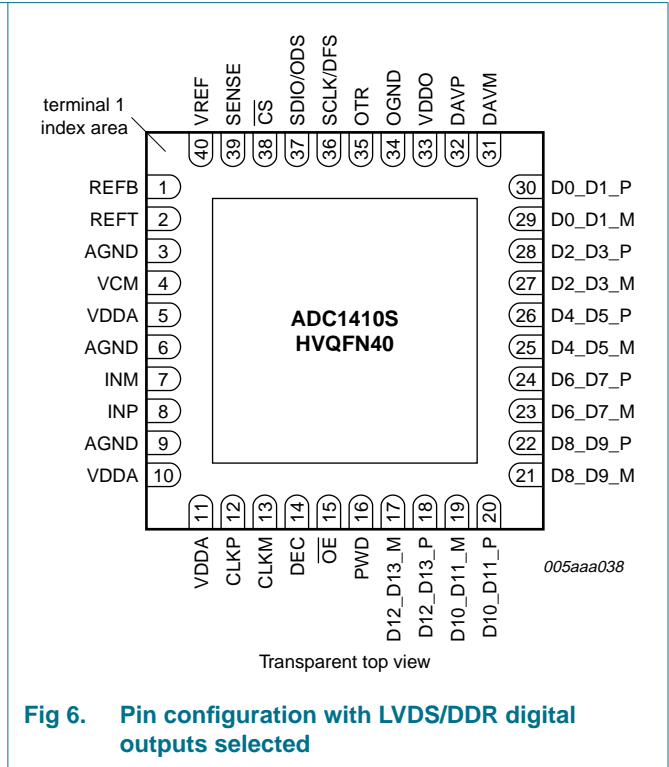

Fig 6. Pin configuration with LVDS/DDR digital outputs selected

6.2 Pin description

Table 2. Pin description (CMOS digital outputs)

Symbol	Pin	Type ^[2]	Description
REFB	1	O	bottom reference
REFT	2	O	top reference
AGND	3	G	analog ground
VCM	4	O	common-mode output voltage
VDDA	5	P	analog power supply
AGND	6	G	analog ground
INM	7	I	complementary analog input
INP	8	I	analog input
AGND	9	G	analog ground
VDDA	10	P	analog power supply
VDDA	11	P	analog power supply
CLKP	12	I	clock input
CLKM	13	I	complementary clock input
DEC	14	O	regulator decoupling node
\overline{OE}	15	I	output enable, active LOW
PWD	16	I	power down, active HIGH

Table 2. Pin description (CMOS digital outputs)

Symbol	Pin	Type ^[2]	Description
D13	17	O	data output bit 13 (MSB)
D12	18	O	data output bit 12
D11	19	O	data output bit 11
D10	20	O	data output bit 10
D9	21	O	data output bit 9
D8	22	O	data output bit 8
D7	23	O	data output bit 7
D6	24	O	data output bit 6
D5	25	O	data output bit 5
D4	26	O	data output bit 4
D3	27	O	data output bit 3
D2	28	O	data output bit 2
D1	29	O	data output bit 1
D0	30	O	data output bit 0 (LSB)
DAV	31	O	data valid output clock
n.c.	32	-	not connected
VDDO	33	P	output power supply
OGND	34	G	output ground
OTR	35	O	out of range
SCLK/DFS	36	I	SPI clock / data format select
SDIO/ODS	37	I/O	SPI data IO / output data standard
$\overline{\text{CS}}$	38	I	SPI chip select
SENSE	39	I	reference programming pin
VREF	40	I/O	voltage reference input/output

[1] P: power supply; G: ground; I: input; O: output; I/O: input/output.

Table 3. Pin description (LVDS/DDR) digital outputs

Symbol	Pin ^[1]	Type ^[2]	Description
D12_D13_M	17	O	differential output data D12 and D13 multiplexed, complement
D12_D13_P	18	O	differential output data D12 and D13 multiplexed, true
D10_D11_M	19	O	differential output data D10 and D11 multiplexed, complement
D10_D11_P	20	O	differential output data D10 and D11 multiplexed, true
D8_D9_M	21	O	differential output data D8 and D9 multiplexed, complement
D8_D9_P	22	O	differential output data D8 and D9 multiplexed, true
D6_D7_M	23	O	differential output data D6 and D7 multiplexed, complement
D6_D7_P	24	O	differential output data D6 and D7 multiplexed, true
D4_D5_M	25	O	differential output data D4 and D5 multiplexed, complement
D4_D5_P	26	O	differential output data D4 and D5 multiplexed, true
D2_D3_M	27	O	differential output data D2 and D3 multiplexed, complement
D2_D3_P	28	O	differential output data D2 and D3 multiplexed, true
D0_D1_M	29	O	differential output data D0 and D1 multiplexed, complement

Table 3. Pin description ...continued (LVDS/DDR) digital outputs)

Symbol	Pin ^[1]	Type ^[2]	Description
D0_D1_P	30	O	differential output data D0 and D1 multiplexed, true
DAVM	31	O	data valid output clock, complement
DAVP	32	O	data valid output clock, true

[1] Pins 1 to 16 and pins 33 to 40 are the same for both CMOS and LVDS DDR outputs (see [Table 2](#))

[2] P: power supply; G: ground; I: input; O: output; I/O: input/output.

7. Limiting values

Table 4. Limiting values

In accordance with the Absolute Maximum Rating System (IEC 60134).

Symbol	Parameter	Conditions	Min	Max	Unit
V_{DDA}	analog supply voltage		<tbid>	<tbid>	V
V_{DDO}	output supply voltage		<tbid>	<tbid>	V
ΔV_{CC}	supply voltage difference	$V_{DDA} - V_{DDO}$	<tbid>	<tbid>	V
T_{stg}	storage temperature		-55	+125	°C
T_{amb}	ambient temperature		-40	+85	°C
T_j	junction temperature		-	<tbid>	°C

8. Thermal characteristics

Table 5. Thermal characteristics

Symbol	Parameter	Conditions	Typ	Unit
$R_{th(j-a)}$	thermal resistance from junction to ambient		[1] <tbid>	K/W
$R_{th(j-c)}$	thermal resistance from junction to case		[1] <tbid>	K/W

[1] In compliance with JEDEC test board, in free air.

9. Static characteristics

Table 6. Static characteristics

Typical values measured at $V_{DDA} = 3\text{ V}$, $V_{DDO} = 1.8\text{ V}$, $T_{amb} = 25\text{ }^\circ\text{C}$ and $C_L = 5\text{ pF}$; min and max values are across the full temperature range $T_{amb} = -40\text{ }^\circ\text{C}$ to $+85\text{ }^\circ\text{C}$ at $V_{DDA} = 3\text{ V}$, $V_{DDO} = 1.8\text{ V}$; $V_{INP} - V_{INM} = -1\text{ dBFS}$; internal reference mode; applied to CMOS and LVDS interface; unless otherwise specified.

Symbol	Parameter	Conditions	Min	Typ	Max	Unit
Supplies						
V_{DDA}	analog supply voltage		2.85	3.0	3.4	V
V_{DDO}	output supply voltage	CMOS mode	1.65	1.8	3.6	V
		LVDS DDR mode	2.85	3.0	3.6	V
I_{DDA}	analog supply current	$f_{clk} = 125\text{ Msps}$; $f_i = 70\text{ MHz}$	-	185	-	mA
I_{DDO}	output supply current	CMOS mode; $f_{clk} = 125\text{ Msps}$; $f_i = 70\text{ MHz}$	-	20	-	mA
		LVDS DDR mode: $f_{clk} = 125\text{ Msps}$; $f_i = 70\text{ MHz}$	-	35	-	mA
P	power dissipation	ADC1410S125	-	557	-	mW
		ADC1410S105	-	488	-	mW
		ADC1410S080	-	387	-	mW
		ADC1410S065	-	336	-	mW
		Power-down mode	-	2	-	mW
		Sleep mode	-	40	-	mW

Clock inputs: pins CLKP and CLKM

AC coupled; LVPECL, LVDS and sine wave

$V_{i(\text{clk})\text{dif}}$	differential clock input voltage	peak-to-peak	0.2	0.8	<tb>	V
-------------------------------	----------------------------------	--------------	-----	-----	------	---

LVC MOS

V_i	input voltage		$0.3V_{DDA}$	-	$0.7V_{DDA}$	V
-------	---------------	--	--------------	---	--------------	---

Logic Inputs: pins PWD and OE

V_{iL}	LOW-level input voltage		0	-	0.8	V
V_{iH}	HIGH-level input voltage		2	-	V_{DDA}	V
I_{iL}	LOW-level input current		<tb>	-	<tb>	μA
I_{iH}	HIGH-level input current		-10	-	+10	μA

Serial Peripheral Interface: pins CS, SDIO/ODS, SCLK/DFS

V_{iL}	LOW-level input voltage		0	-	$0.3V_{DDA}$	V
V_{iH}	HIGH-level input voltage		$0.7V_{DDA}$	-	V_{DDA}	V
I_{iL}	LOW-level input current		-10	-	+10	μA
I_{iH}	HIGH-level input current		-50	-	+50	μA
C_i	input capacitance		-	4	-	pF

Digital Outputs: CMOS mode - pins D13 to D0, OTR, DAV

Output levels, $V_{DDO} = 3\text{ V}$

V_{oL}	LOW-level output voltage	$I_{oL} = \text{<tb>}$	OGND	-	$0.2V_{DDO}$	V
V_{oH}	HIGH-level output voltage	$I_{oH} = \text{<tb>}$	$0.8V_{DDO}$	-	V_{DDO}	V
I_{oL}	LOW-level output current	3-state; output level = 0 V	-	<tb>	-	μA
I_{oH}	HIGH-level output current	3-state; output level = V_{DDA}	-	<tb>	-	μA

Table 6. Static characteristics ...continued

Typical values measured at $V_{DDA} = 3\text{ V}$, $V_{DDO} = 1.8\text{ V}$, $T_{amb} = 25\text{ }^\circ\text{C}$ and $C_L = 5\text{ pF}$; min and max values are across the full temperature range $T_{amb} = -40\text{ }^\circ\text{C}$ to $+85\text{ }^\circ\text{C}$ at $V_{DDA} = 3\text{ V}$, $V_{DDO} = 1.8\text{ V}$; $V_{INP} - V_{INM} = -1\text{ dBFS}$; internal reference mode; applied to CMOS and LVDS interface; unless otherwise specified.

Symbol	Parameter	Conditions	Min	Typ	Max	Unit
C_O	output capacitance	high impedance; $\overline{OE} = \text{HIGH}$	-	3	-	pF
Output levels, $V_{DDO} = 1.8\text{ V}$						
V_{OL}	LOW-level output voltage	$I_{OL} = \text{<tbd>}$	OGND	-	$0.2V_{DDO}$	V
V_{OH}	HIGH-level output voltage	$I_{OH} = \text{<tbd>}$	$0.8V_{DDO}$	-	V_{DDO}	V
Digital Outputs, LVDS mode - pins D13P, D13M to D0P, D0M, DAVP and DAVM						
Output levels, $V_{DDO} = 3\text{ V}$ only, $R_{load} = 100\text{ }\Omega$						
$V_{O(\text{offset})}$	output offset voltage	output buffer current set to 3.5 mA	-	1.2	-	V
$V_{O(\text{dif})}$	differential output voltage	output buffer current set to 3.5 mA	-	350	-	mV
C_O	output capacitance		-	<tbd>	-	pF
Analog inputs: pins INP and INM						
I_I	Input current		-5	-	+5	μA
R_I	Input resistance		-	<tbd>	-	Ω
C_I	Input capacitance		-	5	-	pF
$V_{I(\text{cm})}$	common mode input voltage	$V_{INP} = V_{INM}$	0.9	1.5	2	V
B_i	input bandwidth		-	600	-	MHz
$V_{I(\text{dif})}$	differential input voltage	peak-to-peak	1		2	V
Common mode output voltage: pin VCM						
$V_{O(\text{cm})}$	common-mode output voltage		-	$V_{DDA}/2$	-	V
$I_{O(\text{cm})}$	common-mode output current		-	<tbd>	-	μA
I/O reference voltage: pin VREF						
V_{VREF}	voltage on pin VREF	output	-	0.5 to 1	-	V
		input	0.5	-	1	V
Accuracy						
INL	integral non-linearity		-5	± 1	+5	LSB
DNL	differential non-linearity	guaranteed no missing codes	-0.95	± 0.5	+0.95	LSB
E_{offset}	offset error		-	± 2	-	mV
E_G	gain error			± 0.5		%FS
Supply						
PSRR	power supply rejection ratio	100 mV (p-p) on V_{DDA}	-	35	-	dBc

10. Dynamic characteristics

10.1 Dynamic characteristics

Table 7. Dynamic characteristics

Typical values measured at $V_{DDA} = 3\text{ V}$, $V_{DDO} = 1.8\text{ V}$, $T_{amb} = 25\text{ }^\circ\text{C}$ and $C_L = 5\text{ pF}$; min and max values are across the full temperature range $T_{amb} = -40\text{ }^\circ\text{C}$ to $+85\text{ }^\circ\text{C}$ at $V_{DDA} = 3\text{ V}$, $V_{DDO} = 1.8\text{ V}$; $V_{INP} - V_{INM} = -1\text{ dBFS}$; internal reference mode; applied to CMOS at LVDS interface; unless otherwise specified.

Symbol	Parameter	Conditions	ADC1410S065			ADC1410S080			ADC1410S105			ADC1410S125			Unit
			Min	Typ	Max	Min	Typ	Max	Min	Typ	Max	Min	Typ	Max	
α_{2H}	second harmonic level	$f_i = 3\text{ MHz}$	-	94	-	-	94	-	-	96	-	-	96	-	dBc
		$f_i = 30\text{ MHz}$	-	93	-	-	93	-	-	92	-	-	93	-	dBc
		$f_i = 70\text{ MHz}$	-	90	-	-	91	-	-	91	-	-	91	-	dBc
		$f_i = 170\text{ MHz}$	-	88	-	-	88	-	-	85	-	-	85	-	dBc
α_{3H}	third harmonic level	$f_i = 3\text{ MHz}$	-	92	-	-	93	-	-	91	-	-	90	-	dBc
		$f_i = 30\text{ MHz}$	-	91	-	-	92	-	-	91	-	-	89	-	dBc
		$f_i = 70\text{ MHz}$	-	90	-	-	90	-	-	90	-	-	87	-	dBc
		$f_i = 170\text{ MHz}$	-	88	-	-	87	-	-	88	-	-	87	-	dBc
THD	total harmonic distortion	$f_i = 3\text{ MHz}$	-	88	-	-	88	-	-	87	-	-	87	-	dBc
		$f_i = 30\text{ MHz}$	-	87	-	-	87	-	-	87	-	-	86	-	dBc
		$f_i = 70\text{ MHz}$	-	86	-	-	86	-	-	85	-	-	84	-	dBc
		$f_i = 170\text{ MHz}$	-	83	-	-	83	-	-	82	-	-	82	-	dBc
ENOB	effective number of bits	$f_i = 3\text{ MHz}$	-	11.9	-	-	11.9	-	-	11.8	-	-	11.8	-	bits
		$f_i = 30\text{ MHz}$	-	11.7	-	-	11.7	-	-	11.7	-	-	11.7	-	bits
		$f_i = 70\text{ MHz}$	-	11.6	-	-	11.6	-	-	11.6	-	-	11.6	-	bits
		$f_i = 170\text{ MHz}$	-	11.6	-	-	11.5	-	-	11.5	-	-	11.5	-	bits
SNR	signal-to-noise ratio	$f_i = 3\text{ MHz}$	-	73.2	-	-	73.1	-	-	72.9	-	-	72.5	-	dBFS
		$f_i = 30\text{ MHz}$	-	72.4	-	-	72.3	-	-	72.3	-	-	72.2	-	dBFS
		$f_i = 70\text{ MHz}$	-	71.8	-	-	71.8	-	-	71.7	-	-	71.6	-	dBFS
		$f_i = 170\text{ MHz}$	-	71.3	-	-	71.2	-	-	71.1	-	-	71	-	dBFS
SFDR	spurious-free dynamic range	$f_i = 3\text{ MHz}$	-	91	-	-	91	-	-	90	-	-	90	-	dBc
		$f_i = 30\text{ MHz}$	-	90	-	-	90	-	-	90	-	-	89	-	dBc
		$f_i = 70\text{ MHz}$	-	89	-	-	89	-	-	88	-	-	87	-	dBc
		$f_i = 170\text{ MHz}$	-	86	-	-	86	-	-	85	-	-	85	-	dBc
IMD	Intermodulation distortion	$f_i = 3\text{ MHz}$	-	94	-	-	94	-	-	93	-	-	93	-	dBc
		$f_i = 30\text{ MHz}$	-	93	-	-	93	-	-	93	-	-	92	-	dBc
		$f_i = 70\text{ MHz}$	-	92	-	-	92	-	-	91	-	-	90	-	dBc
		$f_i = 170\text{ MHz}$	-	89	-	-	89	-	-	88	-	-	88	-	dBc

10.2 Clock and digital output timing

Table 8. Clock and digital output timing characteristics

Typical values measured at $V_{DDA} = 3\text{ V}$, $V_{DDO} = 1.8\text{ V}$, $T_{amb} = 25\text{ }^\circ\text{C}$ and $C_L = 5\text{ pF}$; min and max values are across the full temperature range $T_{amb} = -40\text{ }^\circ\text{C}$ to $+85\text{ }^\circ\text{C}$ at $V_{DDA} = 3\text{ V}$, $V_{DDO} = 1.8\text{ V}$; $V_{INP} - V_{INM} = -1\text{ dBFS}$; unless otherwise specified.

Symbol	Parameter	Conditions	ADC1410S065			ADC1410S080			ADC1410S105			ADC1410S125			Unit
			Min	Typ	Max	Min	Typ	Max	Min	Typ	Max	Min	Typ	Max	

Clock timing input: pins CLKP and CLKM

f_{clk}	clock frequency		20	-	65	60	-	80	60	-	105	60	-	125	MHz
$t_{lat(data)}$	data latency time		-	14	-	-	14	-	-	14	-	-	14	-	clk/cy
δ_{clk}	clock duty cycle	DCS_EN = 1	30	50	70	30	50	70	30	50	70	30	50	70	%
		DCS_EN = 0	45	50	55	45	50	55	45	50	55	45	50	55	%
$t_{d(s)}$	sampling delay time		-	0.8	-	-	0.8	-	-	0.8	-	-	0.8	-	ns
t_{wake}	wake-up time		-	tbd	-	-	tbd	-	-	tbd	-	-	tbd	-	ns

CMOS Mode Timing output: pins D13 to D0 and DAV

t_{PD}	propagation delay	DATA	-	3.9	-	-	3.9	-	-	3.9	-	-	3.9	-	ns
		DAV	-	4.2	-	-	4.2	-	-	4.2	-	-	4.2	-	ns
t_{su}	set-up time		-	7.7	-	-	6.5	-	-	4.7	-	-	4.3	-	ns
t_h	hold time		-	6.7	-	-	5.5	-	-	3.8	-	-	3.5	-	ns
t_r	rise time ^[1]	DATA	0.5	-	2.4	0.5	-	2.4	0.5	-	2.4	0.5	-	2.4	ns
		DAV	0.5	-	2.4	0.5	-	2.4	0.5	-	2.4	0.5	-	2.4	ns
t_f	fall time ^[1]	DATA	0.5	-	2.4	0.5	-	2.4	0.5	-	2.4	0.5	-	2.4	ns

LVDS DDR mode timing output: pins D13P, D13M to D0P, D0M, DAVP and DAVM

t_{PD}	propagation delay	DATA	3.9			3.9			3.9			3.9			ns
		DAV	4.2			4.2			4.2			4.2			ns

[1] Measured between 20 % to 80 % of V_{DDO} ; rise time measured from -50 mV to +50 mV; fall time measured from +50 mV to -50 mV.

10.3 SPI Timings

Table 9. Characteristics

Typical values measured at $V_{DDA} = 3\text{ V}$, $V_{DDO} = 1.8\text{ V}$, $T_{amb} = 25\text{ °C}$ and $C_L = 5\text{ pF}$.

Min and max values are across the full temperature range $T_{amb} = -40\text{ °C}$ to $+85\text{ °C}$ at $V_{DDA} = 3\text{ V}$, $V_{DDO} = 1.8\text{ V}$

Symbol	Parameter	Conditions	Min	Typ	Max	Unit
SPI timings						
$t_{w(\text{SCLK})}$	SCLK pulse width		40	-	-	ns
$t_{w(\text{SCLKH})}$	SCLK HIGH pulse width		16	-	-	ns
$t_{w(\text{SCLKL})}$	SCLK LOW pulse width		16	-	-	ns
t_{su}	set-up time	data to SCLKH	5	-	-	ns
		$\overline{\text{CS}}$ to SCLKH	5	-	-	ns
t_h	hold time	data to SCLKH	2	-	-	ns
		$\overline{\text{CS}}$ to SCLKH	2	-	-	ns
$f_{\text{clk(max)}}$	maximum clock frequency		-	-	25	MHz

11. Application information

11.1 Device control

The ADC1410S can be controlled via the Serial Peripheral Interface (SPI control mode) or directly via the I/O pins (PIN control mode).

11.1.1 SPI and PIN control modes

The device enters PIN control mode at power-up, and remains in this mode as long as pin \overline{CS} is held HIGH. In PIN control mode, the SPI pins SDIO, \overline{CS} and SCLK are used as static control pins. SPI settings are ignored.

SPI control mode is enabled by forcing pin \overline{CS} LOW. It is not possible to toggle between PIN control and SPI control modes. Once SPI control mode has been enabled, the device will remain in this mode until it is powered down. The transition from PIN control mode to SPI control mode is illustrated in [Figure 7](#).

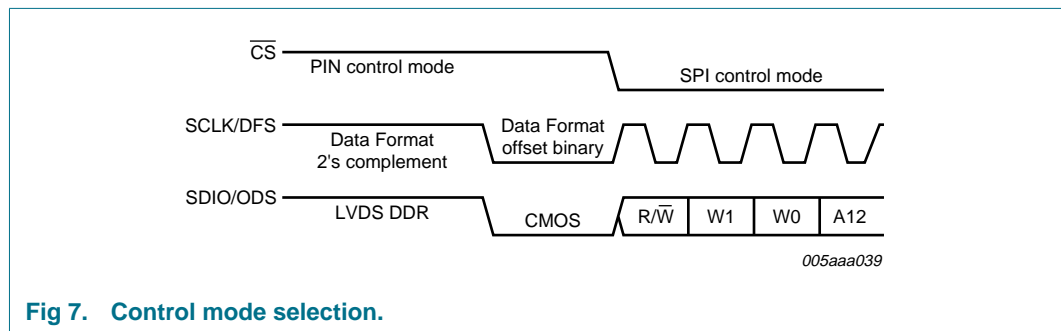

Fig 7. Control mode selection.

When the device enters SPI control mode, the output data standard (CMOS or LVD DDR) is not determined by the state of the relevant SPI control bit (LVDS/CMOS; see [Table 21](#)), but by the level on pin SDIO at the instant a transition is triggered by a falling edge on \overline{CS} (SDIO = LOW = CMOS).

11.1.2 Operating mode selection

The active ADC1410S operating mode (Power-up, Power-down or Sleep) can be selected via the SPI interface (see [Table 18](#)) or using pins PWD and \overline{OE} in PIN control mode, as described in [Table 10](#).

Table 10. Operating mode selection via pin PWD and \overline{OE}

Pin PWD	Pin \overline{OE}	Operating mode	Output high-Z
0	0	Power-up	no
0	1	Power-up	yes
1	0	Sleep	yes
1	1	Power-down	yes

11.1.3 Selecting the output data standard

The output data standard (CMOS or LVDS DDR) can be selected via the SPI interface (see [Table 21](#)) or using pin ODS in PIN control mode. LVDS DDR is selected when ODS is HIGH, otherwise CMOS is selected.

11.1.4 Selecting the output data format

The output data format can be selected via the SPI interface (offset binary, 2's complement or gray code; see [Table 21](#)) or using pin DFS in PIN control mode (offset binary or 2's complement). Offset binary is selected when DFS is LOW. When DFS is HIGH, 2's complement is selected.

11.2 Analog inputs

11.2.1 Input stage

The analog input of the ADC1410S supports differential or single-ended input drive. Optimal performance is achieved using differential inputs with the common-mode input voltage ($V_{I(cm)}$) on pins INP and INM set to $0.5V_{DDA}$.

The full scale analog input voltage range is configurable between 1 V (p-p) and 2 V (p-p) via a programmable internal reference (see [Section 11.3](#) and [Table 20](#) further details).

The equivalent circuit of the sample and hold input stage, including ESD protection and circuit and package parasitics, is shown in [Figure 8](#).

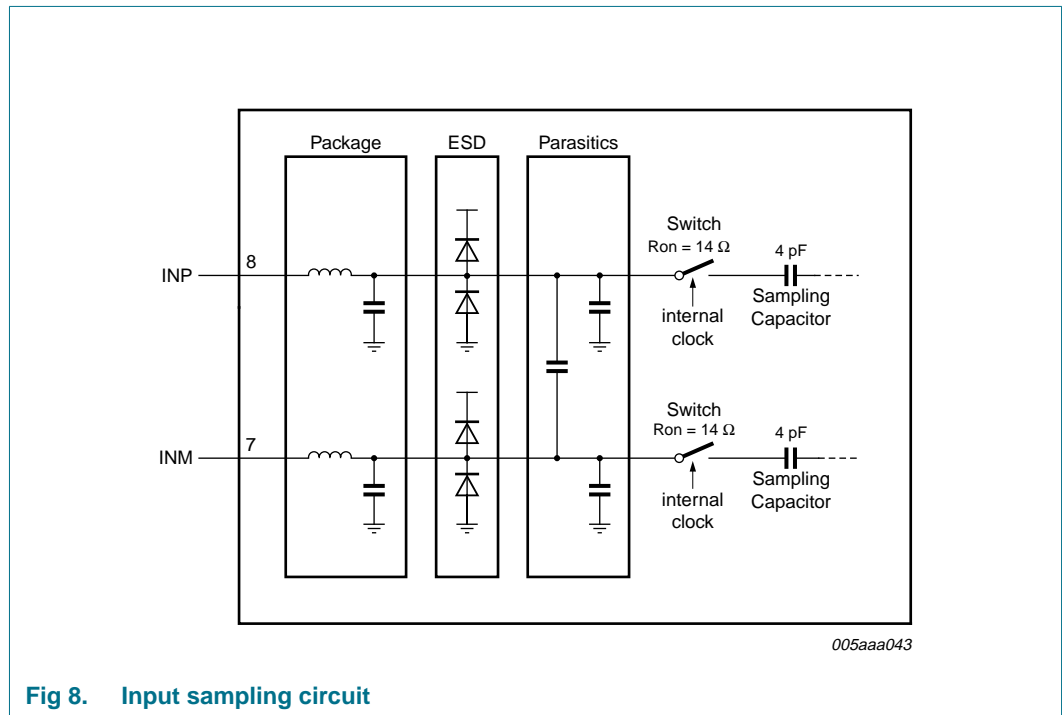

Fig 8. Input sampling circuit

The sample phase occurs when the internal clock (derived from the clock signal on pin CLKP/CLKM) is HIGH. The voltage is then held on the sampling capacitors. When the clock signal goes LOW, the stage enters the hold phase and the voltage information is transmitted to the ADC core.

11.2.2 Anti-kickback circuitry

Anti-kickback circuitry (R-C filter in [Figure 9](#)) is needed to counteract the effects of charge injection generated by the sampling capacitance.

The RC filter is also used to filter noise from the signal before it reaches the sampling stage. The value of the capacitor should be chosen to maximize noise attenuation without degrading the settling time excessively.

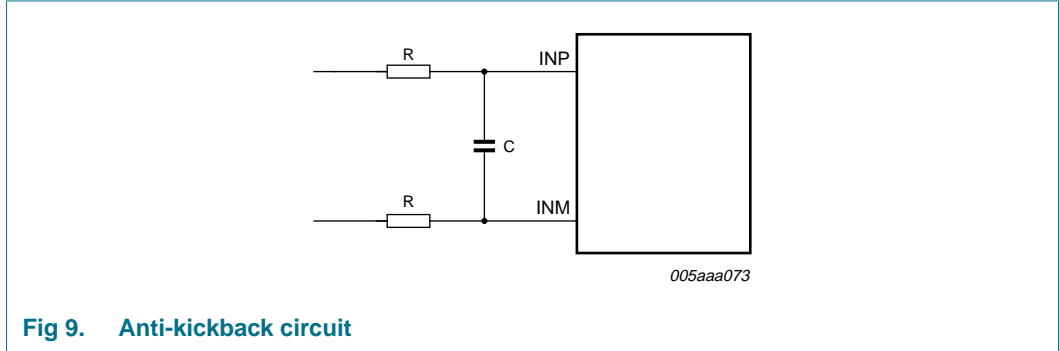

Fig 9. Anti-kickback circuit

The component values are determined by the input frequency and should be selected so as not to affect the input bandwidth.

Table 11. RC coupling versus input frequency - recommended values

Input frequency	R	C
3 MHz	25 Ω	12 pF
70 MHz	12 Ω	8 pF
170 MHz	12 Ω	8 pF

11.2.3 Transformer

The configuration of the transformer circuit is determined by the input frequency. The configuration shown in [Figure 10](#) would be suitable for a baseband application.

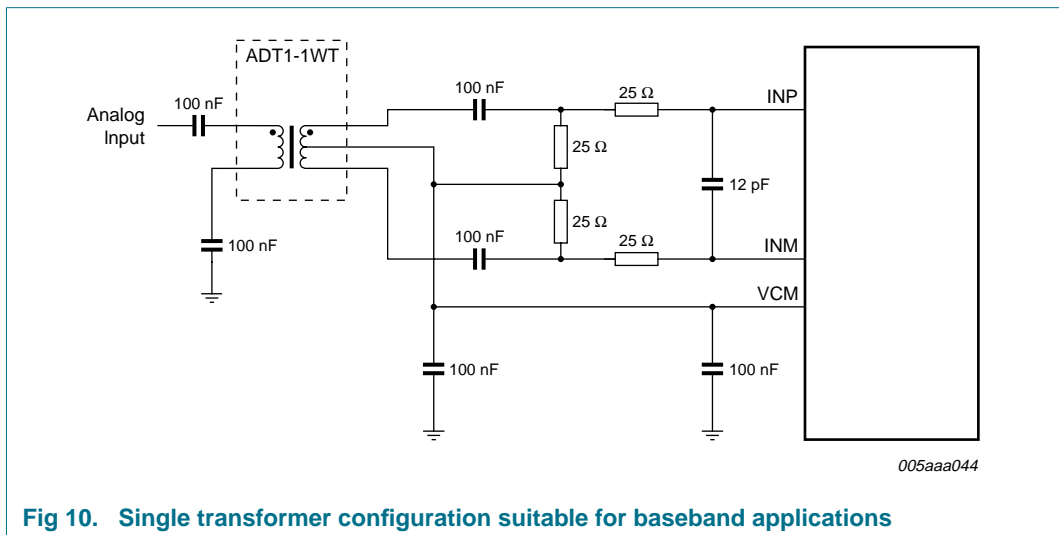

Fig 10. Single transformer configuration suitable for baseband applications

The configuration shown in [Figure 11](#) is recommended for high frequency applications. In both cases, the choice of transformer will be a compromise between cost and performance.

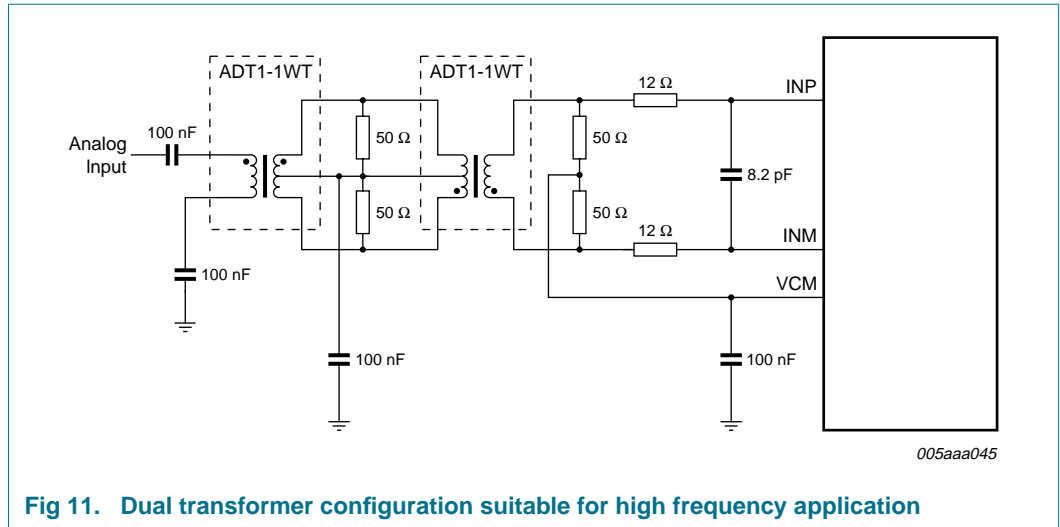

Fig 11. Dual transformer configuration suitable for high frequency application

11.3 System reference and power management

11.3.1 Internal/external references

The ADC1410S has a stable and accurate built-in internal reference voltage. This reference voltage can be set internally, externally or via the SPI (programmable in 1 dB steps between 0 dB and -6 dB via control bits INTREF when bit INTREF_EN = 1; see [Table 20](#)). The equivalent reference circuit is shown in [Figure 12](#).

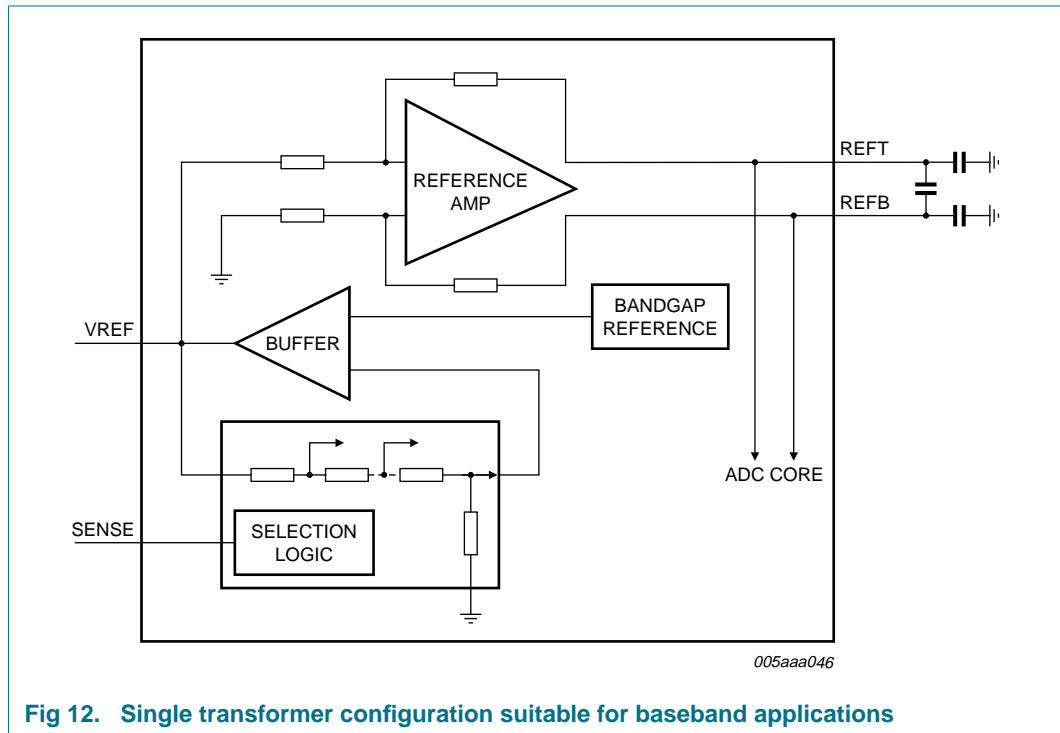

Fig 12. Single transformer configuration suitable for baseband applications

If bit INTREF_EN is set to 0, the reference voltage will be determined either internally or externally as detailed in [Table 12](#).

Table 12. Reference selection

Selection	SPI bit INTREF_EN	SENSE pin	VREF pin	full scale (p-p)
internal	0	AGND	330 pF capacitor to AGND	2 V
internal	0	pin VREF connected to pin SENSE and via a 330 pF capacitor to AGND		1 V
external	0	V _{DDA}	external voltage between 0.5 V and 1 V ^[1]	1 V to 2 V
internal via SPI	1	pin VREF connected to pin SENSE and via 330 pF capacitor to AGND		1 V to 2 V

[1] The voltage on pin VREF is doubled internally to generate the internal reference voltage.

Figure 13 to Figure 16 illustrate how to connect the SENSE and VREF pins to select the required reference voltage source.

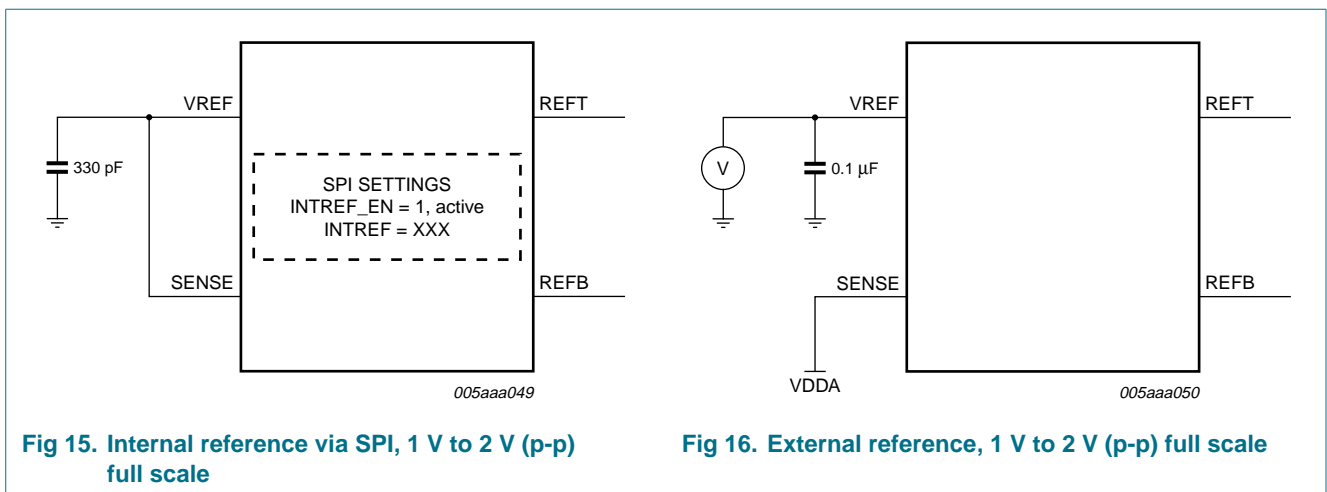
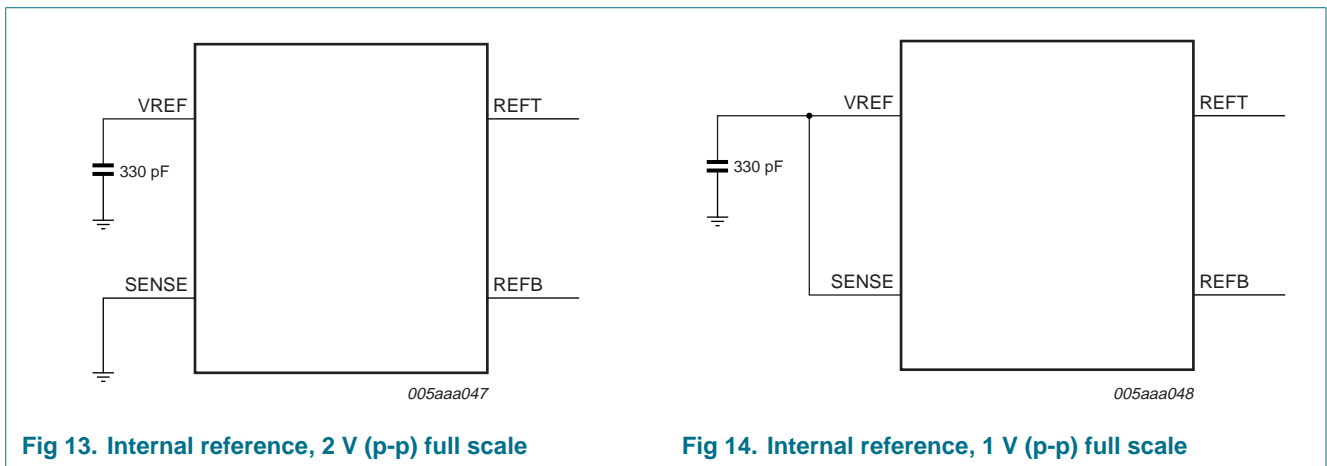

11.3.2 Gain control

The gain is programmable between 0 dB to -6 dB in 1 dB steps via the SPI (see Table 20). This makes it possible to improve the Spurious-Free Dynamic Range (SFDR) of the ADC1410S. The corresponding full scale input voltage range varies between 2 V (p-p) and 1 V (p-p), as shown in Table 13:

Table 13. Reference SPI Gain Control

INTREF	Gain	full scale (p-p)
000	0 dB	2 V
001	-1 dB	1.78 V
010	-2 dB	1.59 V
011	-3 dB	1.42 V
100	-4 dB	1.26 V
101	-5 dB	1.12 V
110	-6 dB	1 V
111	reserved	x

11.3.3 Common-mode output voltage ($V_{O(cm)}$)

A 0.1 μF filter capacitor should be connected between pin VCM and ground to ensure a low-noise common-mode output voltage. When AC-coupled, pin VCM can then be used to set the common-mode reference for the analog inputs, for instance via a transformer middle point.

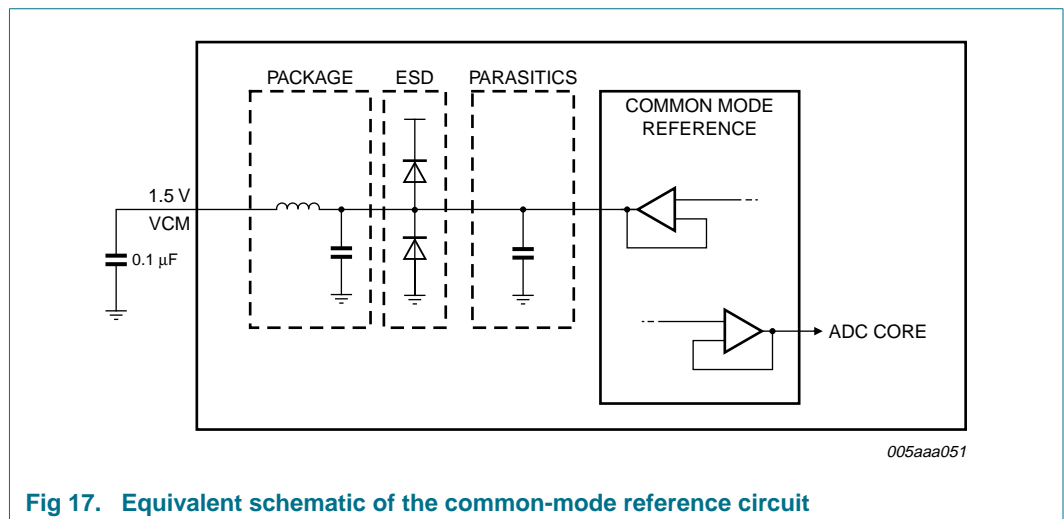
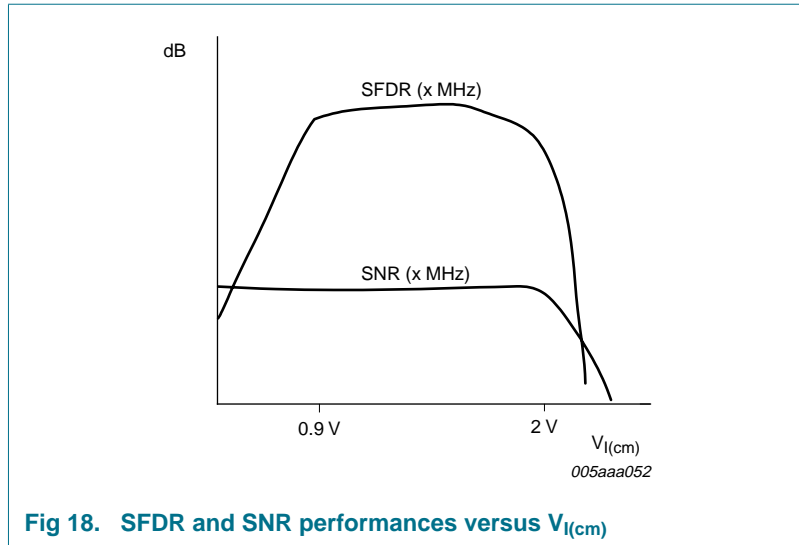

Fig 17. Equivalent schematic of the common-mode reference circuit

11.3.4 Biasing

The common-mode input voltage ($V_{I(cm)}$) on pins INP and INM should be set externally to $0.5V_{DDA}$ for optimal performance and should always be between 0.9 V and 2 V.

The graph in Figure 18 illustrates how the SFDR and SNR characteristics vary with changes in the common-mode input voltage.



11.4 Clock input

11.4.1 Drive modes

The ADC1410S can be driven differentially (SINE, LVPECL or LVDS) without the performance being affected by the choice of configuration. It can also be driven by a single-ended LVC MOS signal connected to pin CLKP (CLKM should be connected to ground via a capacitor) or CLKM (CLKP should be connected to ground via a capacitor).

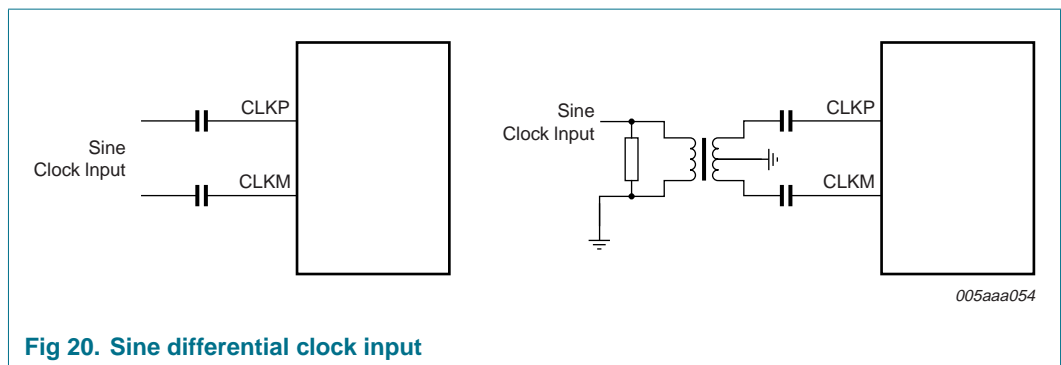
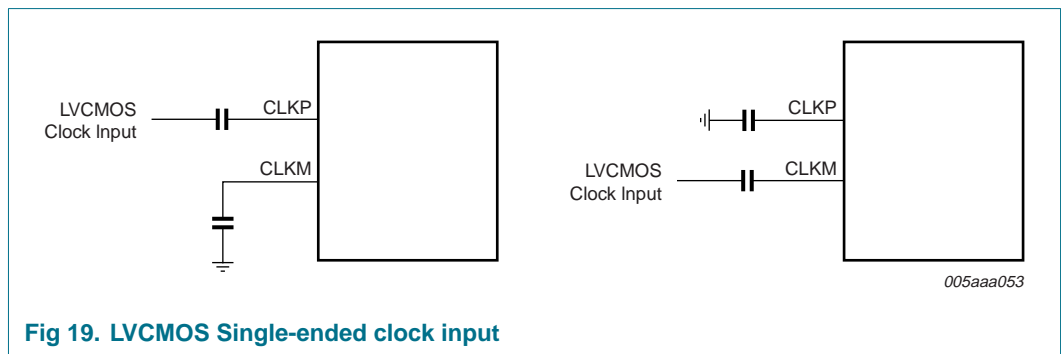

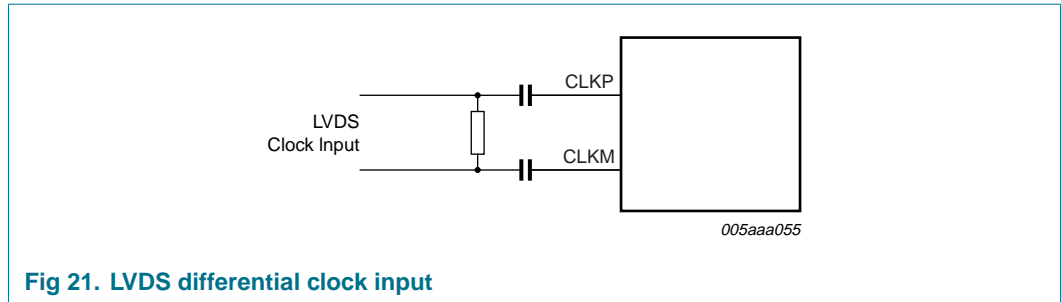

Fig 21. LVDS differential clock input

11.4.2 Equivalent input circuit

The equivalent circuit of the input clock buffer is shown in Figure 22. The common-mode voltage of the differential input stage is set via internal 5 kΩ resistors.

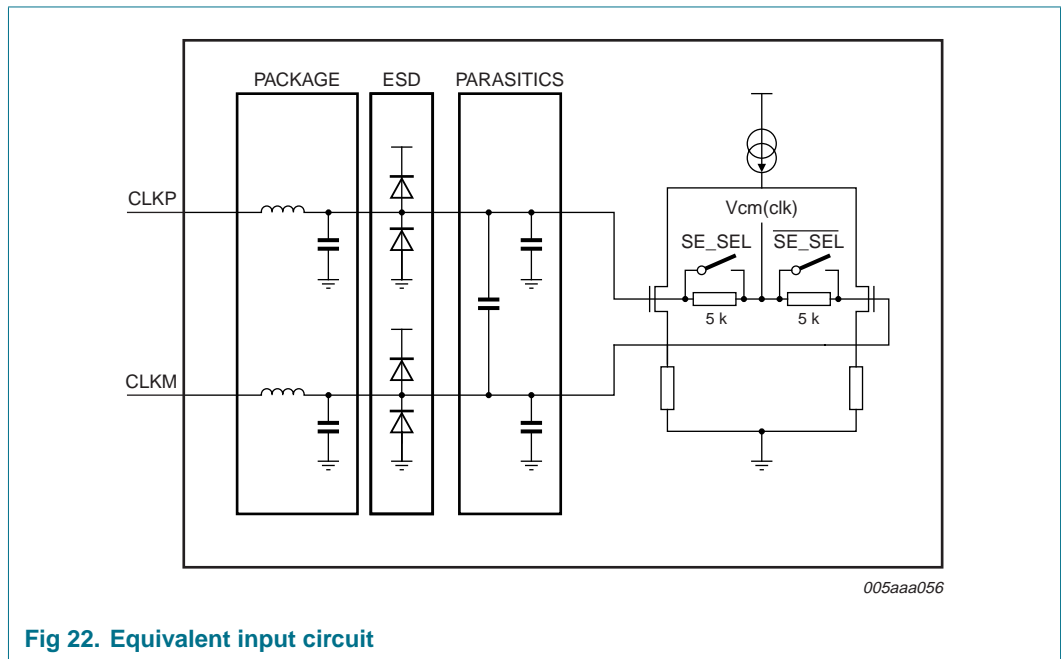

Fig 22. Equivalent input circuit

Single-ended or differential clock inputs can be selected via the SPI interface (see Table 19). If single-ended is enabled, the input pin (CLKM or CLKP) is selected via control bit SE_SEL.

If single-ended is implemented without setting SE_SEL to the appropriate value, the unused pin should be connected to ground via a capacitor.

11.4.3 Duty cycle stabilizer

The duty cycle stabilizer can improve the overall performances of the ADC by compensating the duty cycle of the input clock signal. When the duty cycle stabilizer is active (bit DCS_EN = 1; see Table 19), the circuit can handle signals with duty cycles of between 30 % and 70 % (typical). When the duty cycle stabilizer is disabled (DCS_EN = 0), the input clock signal should have a duty cycle of between 45 % and 55 %.

11.4.4 Clock input divider

The ADC1410S contains an input clock divider that divides the incoming clock by a factor of 2 (when bit CLKDIV = 1; see Table 19). This feature allows the user to deliver a higher clock frequency with better jitter performance, leading to a better SNR result once acquisition has been performed.

11.5 Digital outputs

11.5.1 Digital output buffers: CMOS mode

The digital output buffers can be configured as CMOS by setting bit LVDS/CMOS to 0 (see Table 21).

Each digital output has a dedicated output buffer. The equivalent circuit of the CMOS digital output buffer is shown in Figure 23. The buffer is powered by a separate OGND/V_{DDO} to ensure 1.8 V to 3.4 V compatibility and is isolated from the ADC core. Each buffer can be loaded by a maximum of 10 pF.

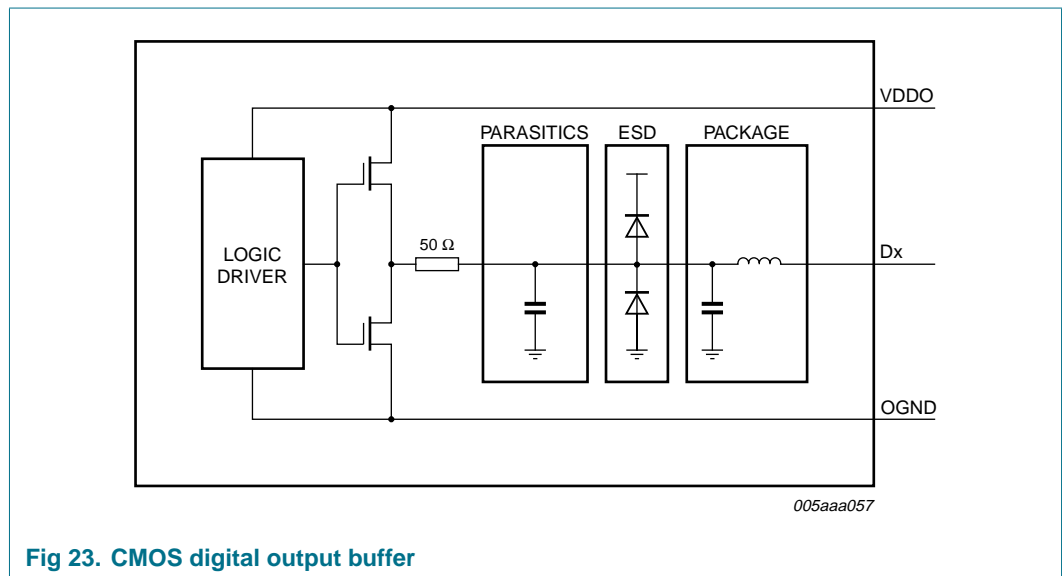

Fig 23. CMOS digital output buffer

The output resistance is 50 Ω and is the combination of the an internal resistor and the equivalent output resistance of the buffer. There is no need for an external damping resistor. The drive strength of both data and DAV buffers can be programmed via the SPI in order to adjust the rise and fall times of the output digital signals (see Table 28):

11.5.2 Digital output buffers: LVDS DDR mode

The digital output buffers can be configured as LVDS DDR by setting bit LVDS/CMOS to 1 (see Table 21).

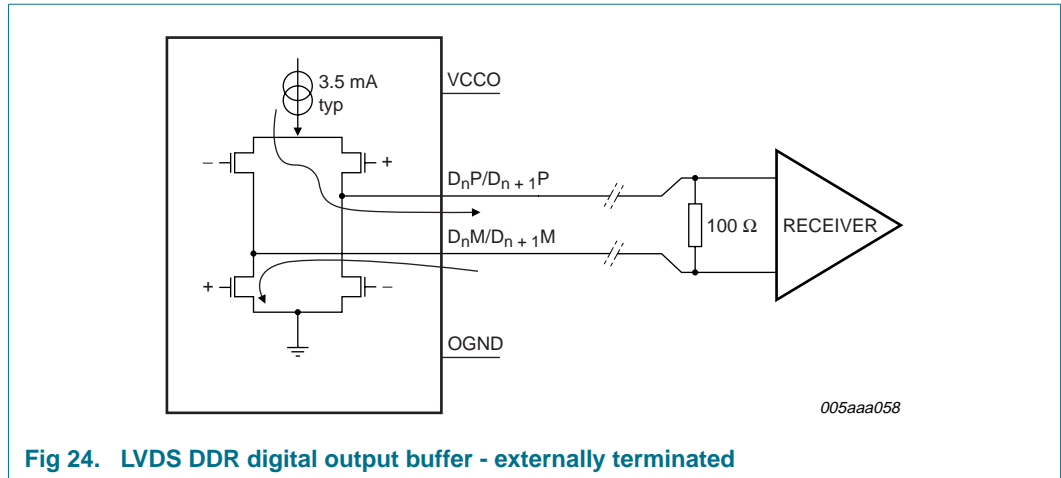

Fig 24. LVDS DDR digital output buffer - externally terminated

Each output should be terminated externally with a 100 Ω resistor (typical) at the receiver side (Figure 24) or internally via SPI control bits LVDS_INTTER (see Figure 25 and Table 30).

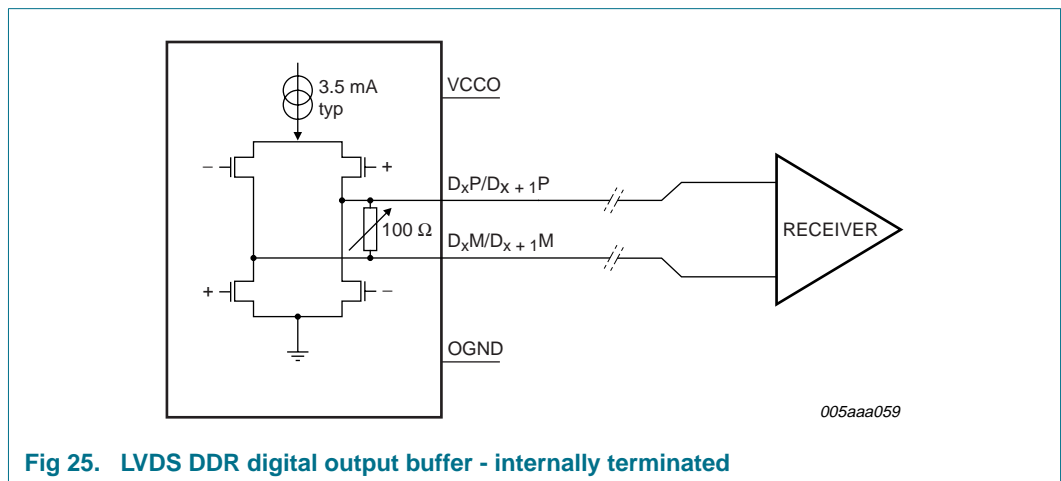

Fig 25. LVDS DDR digital output buffer - internally terminated

The default LVDS DDR output buffer current is set to 3.5 mA. It can be programmed via the SPI (bits DAVI and DATAI; see Table 29) in order to adjust the output logic voltage levels.

11.5.3 Data valid (DAV) output clock

A data valid output clock signal (DAV) is provided that can be used to capture the data delivered by the ADC1410S. Detailed timing diagrams for CMOS and LVDS DDR modes are provided in Figure 26 and Figure 27 respectively.

11.5.4 Out-of-Range (OTR)

An out-of-range signal is provided on pin OTR. By default, pin OTR goes HIGH fourteen clock cycles after an OTR event has occurred. The OTR response can be speeded up by enabling Fast OTR (bit FASTOTR = 1; see Table 27). When Fast OTR is enabled, OTR goes HIGH four clock cycles after the OTR event. The Fast OTR detection threshold (below full scale) can be programmed via bits FASTOTR_DET.

11.5.5 Digital offset

By default, the ADC1410S delivers output code that corresponds to the analog input. However it is possible to add a digital offset to the output code via the SPI (bits DIG_OFFSET; see [Table 23](#)).

11.5.6 Test patterns

For test purposes, the ADC1410S can be configured to transmit one of a number of predefined test patterns (via bits TESTPAT_SEL; see [Table 24](#)). A custom test pattern can be defined by the user (TESTPAT_USER; see [Table 25](#) and [Table 26](#)) and is selected when TESTPAT_SEL = 101. The selected test pattern will be transmitted regardless of the analog input.

11.5.7 Output codes versus input voltage

Table 14. Output codes

$V_{INP} - V_{INM}$	Offset binary	Two's complement	OTR pin
< -1	00 0000 0000 0000	10 0000 0000 0000	1
-1	00 0000 0000 0000	10 0000 0000 0000	0
-0.9998779	00 0000 0000 0001	10 0000 0000 0001	0
-0.9997559	00 0000 0000 0010	10 0000 0000 0010	0
-0.9996338	00 0000 0000 0011	10 0000 0000 0011	0
-0.9995117	00 0000 0000 0100	10 0000 0000 0100	0
....	0
-0.0002441	01 1111 1111 1110	11 1111 1111 1110	0
-0.0001221	01 1111 1111 1111	11 1111 1111 1111	0
0	10 0000 0000 0000	00 0000 0000 0000	0
+0.0001221	10 0000 0000 0001	00 0000 0000 0001	0
+0.0002441	10 0000 0000 0010	00 0000 0000 0010	0
....	0
+0.9995117	11 1111 1111 1011	01 1111 1111 1011	0
+0.9996338	11 1111 1111 1100	01 1111 1111 1100	0
+0.9997559	11 1111 1111 1101	01 1111 1111 1101	0
+0.9998779	11 1111 1111 1110	01 1111 1111 1110	0
+1	11 1111 1111 1111	01 1111 1111 1111	0
> +1	11 1111 1111 1111	01 1111 1111 1111	1

11.6 Timings summary

11.6.1 CMOS mode timings

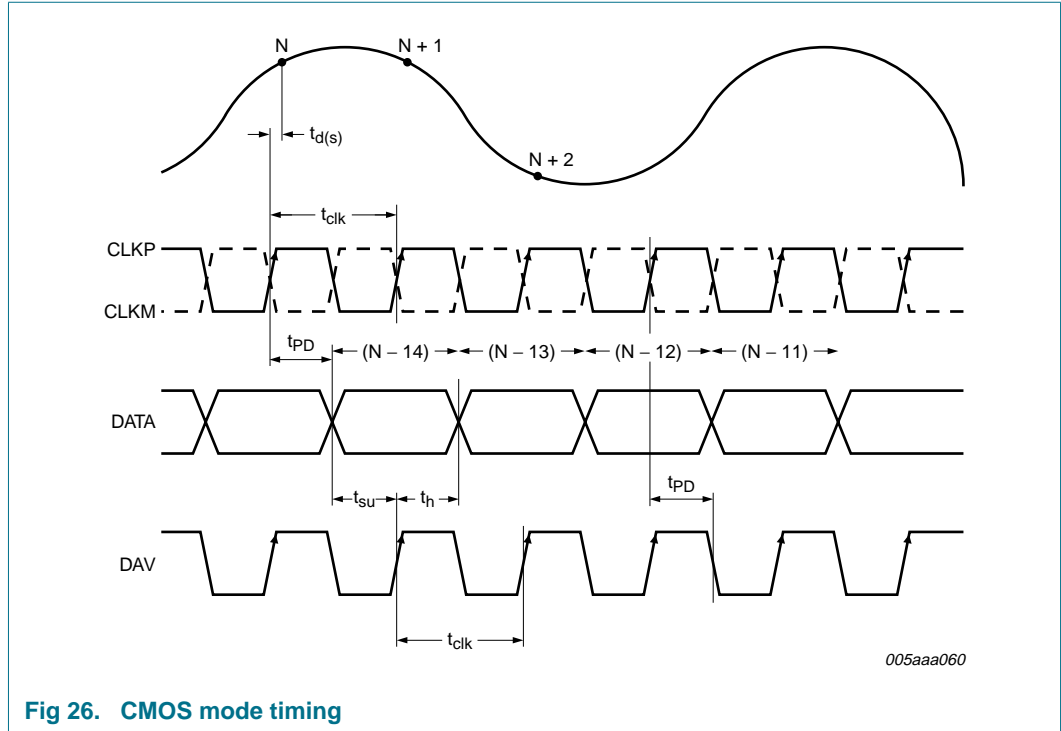

Fig 26. CMOS mode timing

11.6.2 LVDS DDR mode timing

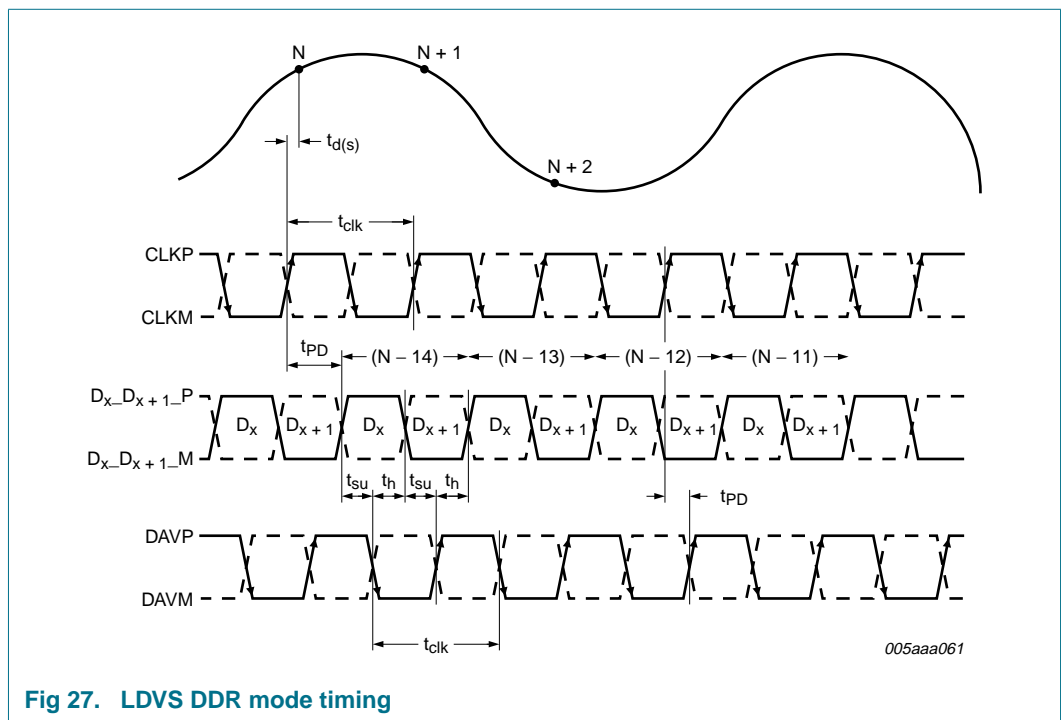

Fig 27. LVDS DDR mode timing

11.7 Serial Peripheral Interface (SPI)

11.7.1 Register description

The ADC1410S serial interface is a synchronous serial communications port that allows for easy interfacing with many commonly-used microprocessors. It provides access to the registers that control the operation of the chip.

This interface is configured as a 3-wire type (SDIO as bidirectional pin)

Pin SCLK is the serial clock input and \overline{CS} is the chip select pin.

Each read/write operation is initiated by a LOW level on \overline{CS} . A minimum of three bytes will be transmitted (two instruction bytes and at least one data byte). The number of data bytes is determined by the value of bits W1 and W2 (see [Table 16](#)).

Table 15. Instruction bytes for the SPI

	MSB							LSB
Bit	7	6	5	4	3	2	1	0
Description	R/ \overline{W} ^[1]	W1 ^[2]	W0 ^[2]	A12	A11	A10	A9	A8
	A7	A6	A5	A4	A3	A2	A1	A0

[1] Bit R/ \overline{W} indicates whether it is a read (1) or a write (0) operation.

[2] Bits W1 and W0 indicate the number of bytes to be transferred after the instruction byte (see [Table 16](#)).

Table 16. Number of data bytes to be transferred after the instruction bytes

W1	W0	Number of bytes transmitted
0	0	1 byte
0	1	2 bytes
1	0	3 bytes
1	1	4 bytes or more

Bits A12 to A0 indicate the address of the register being accessed. In the case of a multiple byte transfer, this address is the first register to be accessed. An address counter is incremented to access subsequent addresses.

The steps involved in a data transfer are as follows:

1. A falling edge on \overline{CS} in combination with a rising edge on SCLK determine the start of communications.
2. The first phase is the transfer of the 2-byte instruction.
3. The second phase is the transfer of the data which can vary in length but will always be a multiple of 8 bits. The MSB is always sent first (for instruction and data bytes).
4. A rising edge on \overline{CS} indicates the end on data transmission.

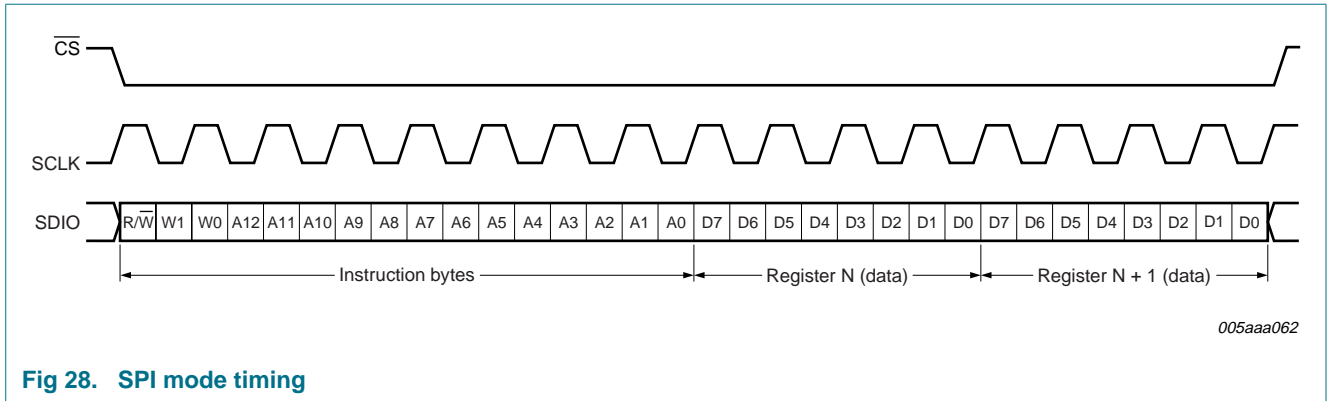

Fig 28. SPI mode timing

11.7.2 Default modes at start-up

During circuit initialization, it doesn't matter which output data standard has been selected. At power-up, the device defaults to PIN control mode.

A falling edge on \overline{CS} will trigger a transition to SPI control mode. When the ADC1410S enters SPI control mode, the output data standard (CMOS/LVDS DDR) is determined by the level on pin SDIO (see Figure 29). Once in SPI control mode, the output data standard can be changed via bit LVDS/CMOS in Table 21.

When the ADC1410S enters SPI control mode, the output data format (2's complement or offset binary) is determined by the level on pin SCLK (grey code can only be selected via the SPI). Once in SPI control mode, the output data format can be changed via bit DATA_FORMAT in Table 21.

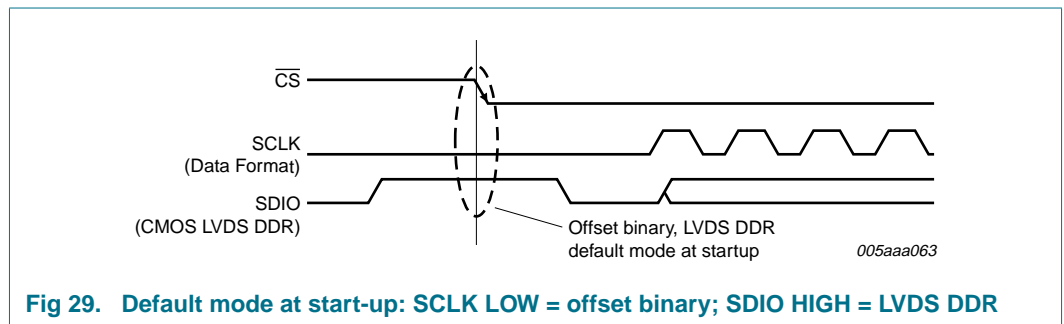

Fig 29. Default mode at start-up: SCLK LOW = offset binary; SDIO HIGH = LVDS DDR

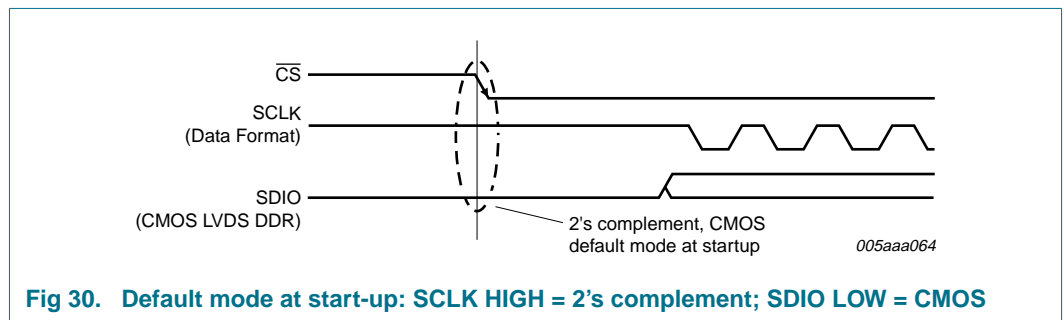

Fig 30. Default mode at start-up: SCLK HIGH = 2's complement; SDIO LOW = CMOS

11.7.3 Register allocation map

Table 17. Register allocation map

Addr Hex	Register name	R/W	Bit definition							Default Bin		
			Bit 7	Bit 6	Bit 5	Bit 4	Bit 3	Bit 2	Bit 1		Bit 0	
0005	Reset and operating mode	R/W	SW_RST	-	-	-	-	-	-	OP_MODE	0000 0000	
0006	Clock	R/W	-	-	-	SE_SEL	DIFF/SE	-	CLKDIV	DCS_EN	0000 0001	
0008	Internal reference	R/W	-	-	-	-	INTREF_EN	INTREF			0000 0000	
0011	Output data standard.	R/W	-	-	-	LVDS/CMOS	OUTBUF	-	DATA_FORMAT		0000 0000	
0012	Output clock	R/W	-	-	-	-	DAVINV	DAVPHASE			0000 1110	
0013	Offset	R/W	-	-	DIG_OFFSET						0000 0000	
0014	Test pattern 1	R/W	-	-	-	-	-	TESTPAT_SEL			0000 0000	
0015	Test pattern 2	R/W	TESTPAT_USER								0000 0000	
0016	Test pattern 2	R/W	TESTPAT_USER							-	-	0000 0000
0017	Fast OTR	R/W	-	-	-	-	FASTOTR	FASTOTR_DET			0000 0000	
0020	CMOS output	R/W	-	-	-	-	DAV_DRV	DATA_DRV			0000 1110	
0021	LVDS DDR O/P 1	R/W	-	-	DAVI_x2_EN	DAVI		DATAI_x2_EN	DATAI		0000 0000	
0022	LVDS DDR O/P 2	R/W	-	-	-	-	BIT/BYTE_WISE	LVDS_INTTER			0000 0000	

Table 18. Reset and operating mode control register (address 0005h) bit description

Bit	Symbol	Access	Value	Description
7	SW_RST	R/W		reset digital section
			0	no reset
			1	performs a reset of the digital section
6 to 2	reserved			
1 to 0	OP_MODE	R/W		operating mode
			00	normal (Power-up)
			01	Power-down
			10	Sleep
			11	normal (Power-up)

Table 19. Clock control register (address 0006h) bit description

Bit	Symbol	Access	Value	Description
7 to 5	reserved			
4	SE_SEL	R/W		single-ended clock input pin select
			0	CLKM
			1	CLKP
3	DIFF/SE	R/W		differential/single ended clock input select
			0	fully differential
			1	single-ended
2	reserved			
1	CLKDIV	R/W		clock input divide by 2
			0	disabled
			1	enabled
0	DCS_EN	R/W		duty cycle stabilizer
			0	disabled
			1	enabled

Table 20. Internal reference control register (address 0008h) bit description

Bit	Symbol	Access	Value	Description
7 to 4	reserved			
3	INTREF_EN	R/W		programmable internal reference enable
			0	disable
			1	active
2 to 0	INTREF	R/W		programmable internal reference
			000	0 dB (FS = 2 V)
			001	-1 dB (FS = 1.78 V)
			010	-2 dB (FS = 1.59 V)
			011	-3 dB (FS = 1.42 V)
			100	-4 dB (FS = 1.26 V)
			101	-5 dB (FS = 1.12 V)
			110	-6 dB (FS = 1 V)
			111	reserved

Table 21. Output data standard control register (address 0011h) bit description

Bit	Symbol	Access	Value	Description
7 to 5	reserved			
4	LVDS/CMOS	R/W		output data standard: LVDS DDR or CMOS
			0	CMOS
			1	LVDS DDR
3	OUTBUF	R/W		output buffers enable
			0	output enabled
			1	output disabled (high Z)
2	reserved			

Table 21. Output data standard control register (address 0011h) bit description ...continued

Bit	Symbol	Access	Value	Description
1 to 0	DATA_FORMAT	R/W		output data format
			00	offset binary
			01	2's complement
			10	gray code
			11	offset binary

Table 22. Output clock register (address 0012h) bit description

Bit	Symbol	Access	Value	Description
7 to 4	reserved			
3	DAVINV	R/W		output clock data valid (DAV) polarity
			0	normal
			1	inverted
2 to 0	DAVPHASE	R/W		DAV phase select
			000	output clock shifted (ahead) by 3 ns
			001	output clock shifted (ahead) by 2.5 ns
			010	output clock shifted (ahead) by 2 ns
			011	output clock shifted (ahead) by 1.5 ns
			100	output clock shifted (ahead) by 1 ns
			101	output clock shifted (ahead) by 0.5 ns
			110	default value as defined in timing section
			111	output clock shifted (delayed) by 0.5 ns

Table 23. Offset register (address 0013h) bit description

Bit	Symbol	Access	Value	Description
7 to 6	reset			
5 to 0	DIG_OFFSET	R/W		digital offset adjustment
			011111	+31 LSB
		
			000000	0
		
			100000	-32 LSB

Table 24. Test pattern register 1(address 0014h) bit description

Bit	Symbol	Access	Value	Description
7 to 3	reserved			
2 to 0	TESTPAT_SEL	R/W		digital test pattern select
			000	off
			001	mid scale
			010	-FS
			011	+FS
			100	toggle '1111..1111'/'0000..0000'
			101	custom test pattern
			110	'1010..1010.'
			111	'010..1010'

Table 25. Test pattern register 2 (address 0015h) bit description

Bit	Symbol	Access	Value	Description
7 to 0	TESTPAT_USER	R/W		custom digital test pattern (bits 13 to 6)

Table 26. Test pattern register 3 (address 0016h) bit description

Bit	Symbol	Access	Value	Description
7 to 2	TESTPAT_USER	R/W		custom digital test pattern (bits 5 to 0)
1 to 0	reserved			

Table 27. Fast OTR register (address 0017h) bit description

Bit	Symbol	Access	Value	Description
7 to 4	reset			
3	FASTOTR	R/W		fast Out-of-Range (OTR) detection
			0	disabled
			1	enabled
2 to 0	FASTOTR_DET	R/W		set fast OTR detect level
			000	-20.56 dB
			001	-16.12 dB
			010	-11.02 dB
			011	-7.82 dB
			100	-5.49 dB
			101	-3.66 dB
			110	-2.14 dB
			111	-0.86 dB

Table 28. CMOS output register (address 0020h) bit description

Bit	Symbol	Access	Value	Description
7 to 4	reserved			
3 to 2	DAV_DRV	R/W		drive strength for DAV CMOS output buffer
			00	low
			01	medium
			10	high
1 to 0	DATA_DRV	R/W		drive strength for DATA CMOS output buffer
			00	low
			01	medium
			10	high
			11	very high

Table 29. LVDS DDR output register 1 (address 0021h) bit description

Bit	Symbol	Access	Value	Description
7 to 6				
5	DAVI_x2_EN	R/W		double LVDS current for DAV LVDS buffer
			0	disabled
			1	enabled
4 to 3	DAVI	R/W		LVDS current for DAV LVDS buffer
			00	3.5 mA
			01	4.5 mA
			10	1.25 mA
			11	2.5 mA
2	DATAI_x2_EN	R/W		double LVDS current for DATA LVDS buffer
			0	disabled
			1	enabled
1 to 0	DATAI	R/W		LVDS current for DATA LVDS buffer
			00	3.5 mA
			01	4.5 mA
			10	1.25 mA
			11	2.5 mA

Table 30. LVDS DDR output register 2 (address 0022h) bit description

Bit	Symbol	Access	Value	Description
7 to 4	reserved			
3	BIT/BYTE_WISE	R/W		DDR mode for LVDS output
			0	bit wise (even data bits output on DAV rising edge / odd data bits output on DAV falling edge)
			1	byte wise (MSB data bits output on DAV rising edge / LSB data bits output on DAV falling edge)

Table 30. LVDS DDR output register 2 (address 0022h) bit description ...continued

Bit	Symbol	Access	Value	Description
2 to 0	LVDS_INTTER	R/W		internal termination for LVDS buffer (DAV and DATA)
			000	no internal termination
			001	300 Ω
			010	180 Ω
			011	110 Ω
			100	150 Ω
			101	100 Ω
			110	81 Ω
			111	60 Ω

11.7.4 Serial timing interface

SPI timing is shown in Figure 31.

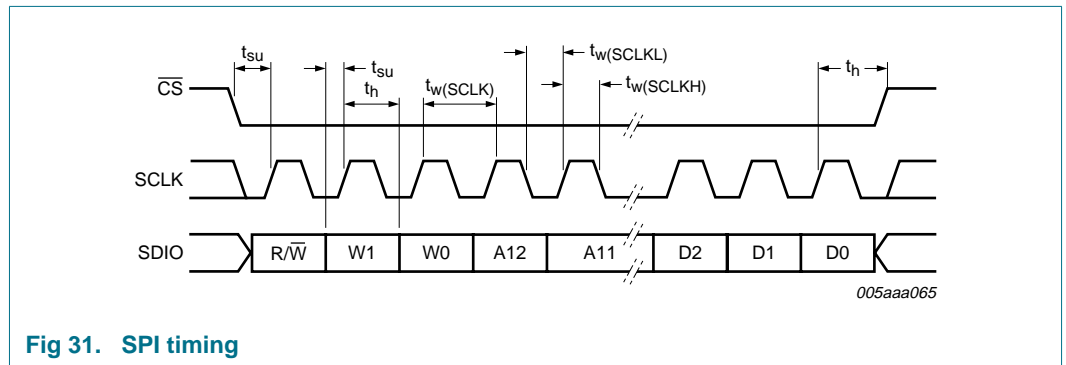

Fig 31. SPI timing

SPI timing characteristics are detailed in Table 9.

12. Package outline

HVQFN40: plastic thermal enhanced very thin quad flat package; no leads; 40 terminals; body 6 x 6 x 0.85 mm

SOT618-1

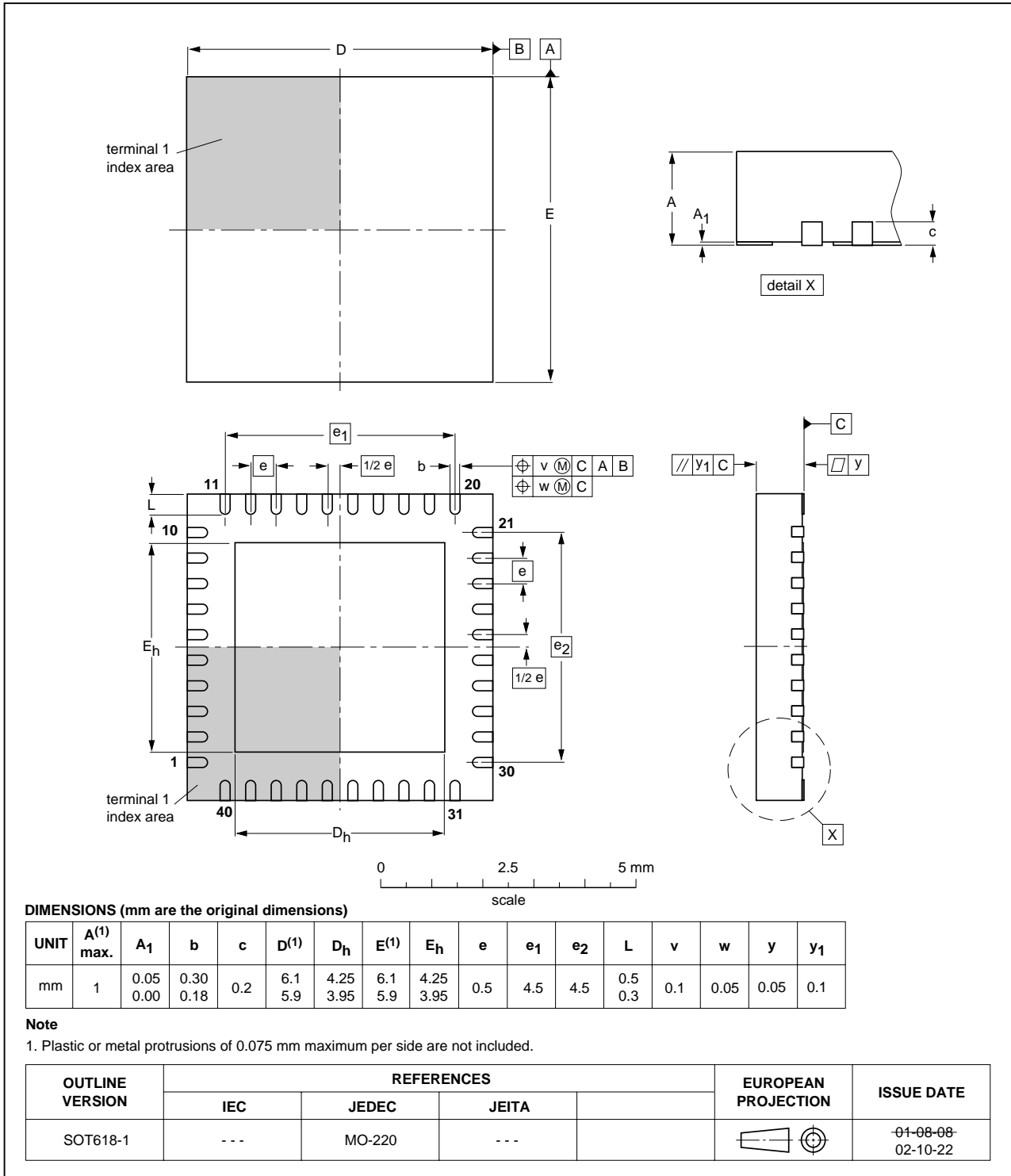

Fig 32. Package outline SOT618-1 (HVQFN40)

13. Revision history

Table 31. Revision history

Document ID	Release date	Data sheet status	Change notice	Supersedes
ADC1410S065_080_105_125_2	20090604	Objective data sheet	-	ADC1410S065_080_105_125_1
Modifications:	• Values in Table 7 have been updated			
ADC1410S065_080_105_125_1	20090528	Objective data sheet	-	-

14. Legal information

14.1 Data sheet status

Document status ^{[1][2]}	Product status ^[3]	Definition
Objective [short] data sheet	Development	This document contains data from the objective specification for product development.
Preliminary [short] data sheet	Qualification	This document contains data from the preliminary specification.
Product [short] data sheet	Production	This document contains the product specification.

[1] Please consult the most recently issued document before initiating or completing a design.

[2] The term 'short data sheet' is explained in section "Definitions".

[3] The product status of device(s) described in this document may have changed since this document was published and may differ in case of multiple devices. The latest product status information is available on the Internet at URL <http://www.nxp.com>.

14.2 Definitions

Draft — The document is a draft version only. The content is still under internal review and subject to formal approval, which may result in modifications or additions. NXP Semiconductors does not give any representations or warranties as to the accuracy or completeness of information included herein and shall have no liability for the consequences of use of such information.

Short data sheet — A short data sheet is an extract from a full data sheet with the same product type number(s) and title. A short data sheet is intended for quick reference only and should not be relied upon to contain detailed and full information. For detailed and full information see the relevant full data sheet, which is available on request via the local NXP Semiconductors sales office. In case of any inconsistency or conflict with the short data sheet, the full data sheet shall prevail.

14.3 Disclaimers

General — Information in this document is believed to be accurate and reliable. However, NXP Semiconductors does not give any representations or warranties, expressed or implied, as to the accuracy or completeness of such information and shall have no liability for the consequences of use of such information.

Right to make changes — NXP Semiconductors reserves the right to make changes to information published in this document, including without limitation specifications and product descriptions, at any time and without notice. This document supersedes and replaces all information supplied prior to the publication hereof.

Suitability for use — NXP Semiconductors products are not designed, authorized or warranted to be suitable for use in medical, military, aircraft, space or life support equipment, nor in applications where failure or malfunction of an NXP Semiconductors product can reasonably be expected to result in personal injury, death or severe property or environmental

damage. NXP Semiconductors accepts no liability for inclusion and/or use of NXP Semiconductors products in such equipment or applications and therefore such inclusion and/or use is at the customer's own risk.

Applications — Applications that are described herein for any of these products are for illustrative purposes only. NXP Semiconductors makes no representation or warranty that such applications will be suitable for the specified use without further testing or modification.

Limiting values — Stress above one or more limiting values (as defined in the Absolute Maximum Ratings System of IEC 60134) may cause permanent damage to the device. Limiting values are stress ratings only and operation of the device at these or any other conditions above those given in the Characteristics sections of this document is not implied. Exposure to limiting values for extended periods may affect device reliability.

Terms and conditions of sale — NXP Semiconductors products are sold subject to the general terms and conditions of commercial sale, as published at <http://www.nxp.com/profile/terms>, including those pertaining to warranty, intellectual property rights infringement and limitation of liability, unless explicitly otherwise agreed to in writing by NXP Semiconductors. In case of any inconsistency or conflict between information in this document and such terms and conditions, the latter will prevail.

No offer to sell or license — Nothing in this document may be interpreted or construed as an offer to sell products that is open for acceptance or the grant, conveyance or implication of any license under any copyrights, patents or other industrial or intellectual property rights.

Export control — This document as well as the item(s) described herein may be subject to export control regulations. Export might require a prior authorization from national authorities.

14.4 Trademarks

Notice: All referenced brands, product names, service names and trademarks are the property of their respective owners.

15. Contact information

For more information, please visit: <http://www.nxp.com>

For sales office addresses, please send an email to: salesaddresses@nxp.com

16. Contents

1	General description	1	11.7	Serial Peripheral Interface (SPI)	24
2	Features	1	11.7.1	Register description	24
3	Applications	2	11.7.2	Default modes at start-up	25
4	Ordering information	2	11.7.3	Register allocation map	26
5	Block diagram	3	11.7.4	Serial timing interface	31
6	Pinning information	4	12	Package outline	32
6.1	Pinning	4	13	Revision history	33
6.2	Pin description	4	14	Legal information	34
7	Limiting values	6	14.1	Data sheet status	34
8	Thermal characteristics	6	14.2	Definitions	34
9	Static characteristics	7	14.3	Disclaimers	34
10	Dynamic characteristics	9	14.4	Trademarks	34
10.1	Dynamic characteristics	9	15	Contact information	34
10.2	Clock and digital output timing	10	16	Contents	35
10.3	SPI Timings	11			
11	Application information	12			
11.1	Device control	12			
11.1.1	SPI and PIN control modes	12			
11.1.2	Operating mode selection	12			
11.1.3	Selecting the output data standard	12			
11.1.4	Selecting the output data format	13			
11.2	Analog inputs	13			
11.2.1	Input stage	13			
11.2.2	Anti-kickback circuitry	13			
11.2.3	Transformer	14			
11.3	System reference and power management	15			
11.3.1	Internal/external references	15			
11.3.2	Gain control	16			
11.3.3	Common-mode output voltage ($V_{O(cm)}$)	17			
11.3.4	Biasing	17			
11.4	Clock input	18			
11.4.1	Drive modes	18			
11.4.2	Equivalent input circuit	19			
11.4.3	Duty cycle stabilizer	19			
11.4.4	Clock input divider	20			
11.5	Digital outputs	20			
11.5.1	Digital output buffers: CMOS mode	20			
11.5.2	Digital output buffers: LVDS DDR mode	20			
11.5.3	Data valid (DAV) output clock	21			
11.5.4	Out-of-Range (OTR)	21			
11.5.5	Digital offset	22			
11.5.6	Test patterns	22			
11.5.7	Output codes versus input voltage	22			
11.6	Timings summary	23			
11.6.1	CMOS mode timings	23			
11.6.2	LVDS DDR mode timing	23			

Please be aware that important notices concerning this document and the product(s) described herein, have been included in section 'Legal information'.



© NXP B.V. 2009.

All rights reserved.

For more information, please visit: <http://www.nxp.com>

For sales office addresses, please send an email to: salesaddresses@nxp.com

Date of release: 4 June 2009

Document identifier: ADC1410S065_080_105_125_2