

# IP3253CZ8/CZ12/CZ16

Integrated 4-, 6- and 8-channel passive filter network with ESD input protection to IEC 61000-4-2 level 4

Rev. 02 — 16 October 2009

Objective data sheet

## 1. Product profile

---

### 1.1 General description

The IP3253CZ8/CZ12/CZ16 family consists of 4-, 6- and 8-channel LC low-pass filter arrays designed to filter unwanted RF signals on the I/O ports of portable communication, computing and media player devices. In addition, the IP3253CZ8/CZ12/CZ16 family incorporates diodes which protect downstream components from ElectroStatic Discharge (ESD) voltages as high as  $\pm 15$  kV.

These devices are fabricated using monolithic silicon technology and integrate up to 8 inductors and 16 diodes in a 0.4 mm pitch 8-, 12- or 16-pin MicroPak lead-free plastic package. The package is QFN compatible and has a height of only 0.5 mm.

### 1.2 Features

- Pb-free, Restriction of Hazardous Substances (RoHS) and Dark Green compliant
- 4-, 6- and 8-channel integrated  $\pi$ -type LC filter network
- ESD protection to  $\pm 15$  kV contact discharge according to IEC 61000-4-2 standard far exceeding level 4
- ESD protection to  $\pm 30$  kV contact discharge according to MIL-STD-883 (Method 3015) Human Body Model
- UTLP (QFN compatible) plastic package with 0.4 mm pitch

### 1.3 Applications

- General purpose ElectroMagnetic Interference (EMI), Radio-Frequency Interference (RFI) filtering and downstream ESD protection for:
  - ◆ Cellular phone and Personal Communication System (PCS) mobile handsets
  - ◆ Cordless telephones
  - ◆ Wireless data (WAN/LAN) systems

## 2. Pinning information

**Table 1. Pinning IP3253CZ8/CZ12/CZ16**

Pin	Description	Simplified outline	Symbol
<b>CZ8</b>			
1 and 8	filter channel 1	<p>Transparent top view</p>	<p>001aaJ745</p>
2 and 7	filter channel 2		
3 and 6	filter channel 3		
4 and 5	filter channel 4		
ground pad	ground		
<b>CZ12</b>			
1 and 12	filter channel 1	<p>Transparent top view</p>	<p>001aaJ746</p>
2 and 11	filter channel 2		
3 and 10	filter channel 3		
4 and 9	filter channel 4		
5 and 8	filter channel 5		
6 and 7	filter channel 6		
ground pad	ground		
<b>CZ16</b>			
1 and 16	filter channel 1	<p>Transparent top view</p>	<p>001aaJ747</p>
2 and 15	filter channel 2		
3 and 14	filter channel 3		
4 and 13	filter channel 4		
5 and 12	filter channel 5		
6 and 11	filter channel 6		
7 and 10	filter channel 7		
8 and 9	filter channel 8		
ground pad	ground		

### 3. Ordering information

**Table 2. Ordering information**

Type number	Package		Version
	Name	Description	
IP3253CZ8-4	HXSON8U	plastic thermal enhanced extremely thin small outline package; no leads; 8 terminals; UTLP based; body 1.35 × 1.7 × 0.5 mm	SOT983-1
IP3253CZ12-6	HXSON12U	plastic thermal enhanced extremely thin small outline package; no leads; 12 terminals; UTLP based; body 1.35 × 2.5 × 0.5 mm	SOT984-1
IP3253CZ16-8	HXSON16U	plastic thermal enhanced extremely thin small outline package; no leads; 16 terminals; UTLP based; body 1.35 × 3.3 × 0.5 mm	SOT985-1

### 4. Limiting values

**Table 3. Limiting values**

*In accordance with the Absolute Maximum Rating System (IEC 60134).*

Symbol	Parameter	Conditions	Min	Max	Unit
V <sub>CC</sub>	supply voltage		-0.5	+5.6	V
V <sub>ESD</sub>	electrostatic discharge voltage	all pins to ground; contact discharge			
		Human Body Model; MIL-STD-883, Method 3015	-30	+30	kV
		IEC 61000-4-2, level 4	-15	+15	kV
I <sub>ch</sub>	channel current (DC)	T <sub>amb</sub> = 85 °C	-	20	mA
T <sub>stg</sub>	storage temperature		-65	+150	°C
T <sub>amb</sub>	ambient temperature		-40	+85	°C

## 5. Characteristics

**Table 4. Channel characteristics**

$T_{amb} = 25\text{ }^{\circ}\text{C}$  unless otherwise specified.

Symbol	Parameter	Conditions	Min	Typ	Max	Unit	
$L_{s(ch)}$	channel series inductance		-	18	-	nH	
$C_{ch}$	channel capacitance	for the total channel; $f_i = 100\text{ kHz}$					
		$V_{bias(DC)} = 2.5\text{ V}$	[1]	20	25	30	pF
		$V_{bias(DC)} = 0\text{ V}$	[1]	-	43	-	pF
$I_{LR}$	reverse leakage current	per channel; $V_i = 3.5\text{ V}$	-	-	0.1	$\mu\text{A}$	
$V_{BR}$	breakdown voltage	positive clamp; $I_i = 1\text{ mA}$	5.8	-	10	V	
$V_F$	forward voltage	negative clamp; $I_F = -1\text{ mA}$	-1.5	-	-0.4	V	

[1] Guaranteed by design.

**Table 5. Frequency characteristics**

$T_{amb} = 25\text{ }^{\circ}\text{C}$  unless otherwise specified.

Symbol	Parameter	Conditions	Min	Typ	Max	Unit
$\alpha_{il}$	insertion loss	$R_{source} = 50\text{ }\Omega$ ; $R_L = 50\text{ }\Omega$ ; $1\text{ GHz} < f_i < 4\text{ GHz}$	-	30	-	dB
$f_{-3dB}$	cut-off frequency	$R_{source} = 50\text{ }\Omega$ ; $R_L = 50\text{ }\Omega$ ; $V = 0\text{ V}$	-	175	-	MHz
$f_{roll-off}$	roll-off frequency	measured at $f_i = -6\text{ dB}$ ; $R_{source} = 50\text{ }\Omega$ ; $R_L = 50\text{ }\Omega$ ; $V = 0\text{ V}$	-	370	-	MHz

## 6. Application information

### 6.1 Insertion loss

The devices are specifically designed as EMI/RFI filters for multichannel interfaces.

The block schematic for measuring insertion loss in a  $50\text{ }\Omega$  system is shown in [Figure 1](#). An example of the measurement curves for all channels is shown in [Figure 2](#).

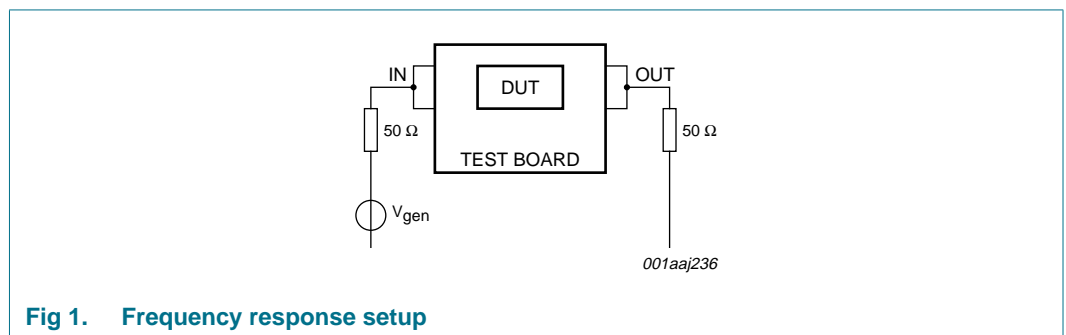

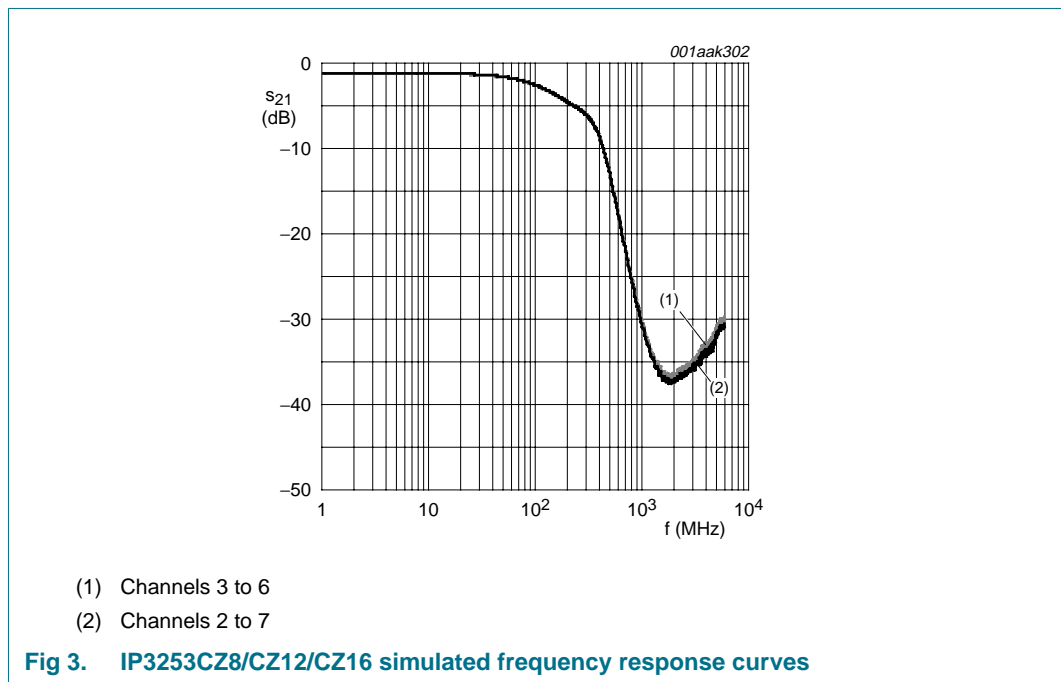
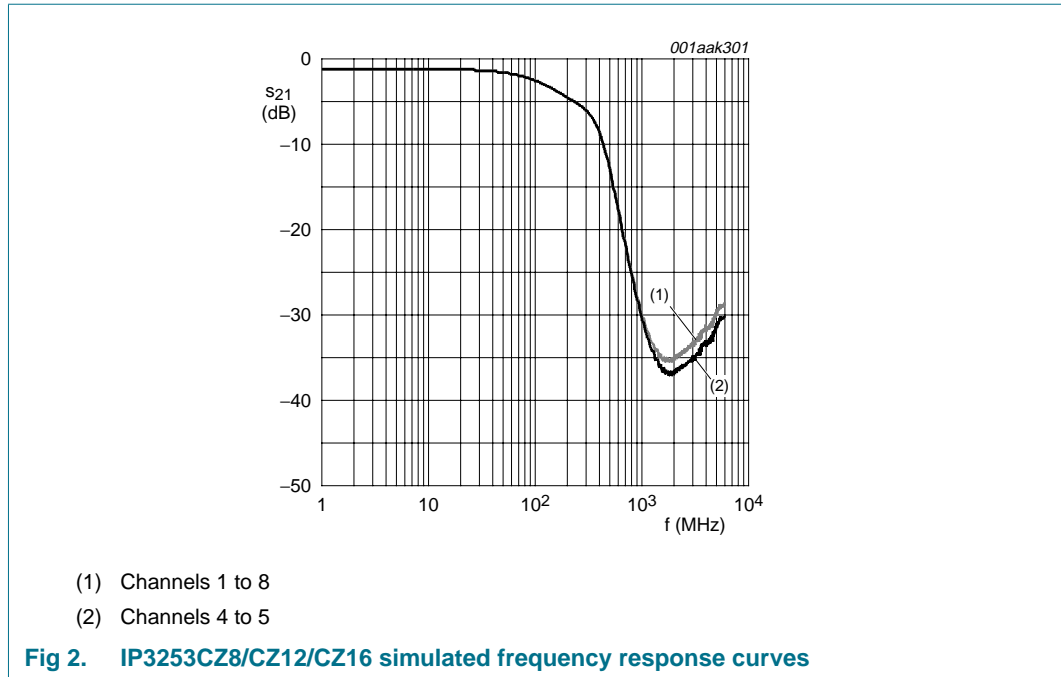

7. Package outline

HXSON8U: plastic thermal enhanced extremely thin small outline package; no leads;  
8 terminals; UTLP based; body 1.35 x 1.7 x 0.5 mm

SOT983-1

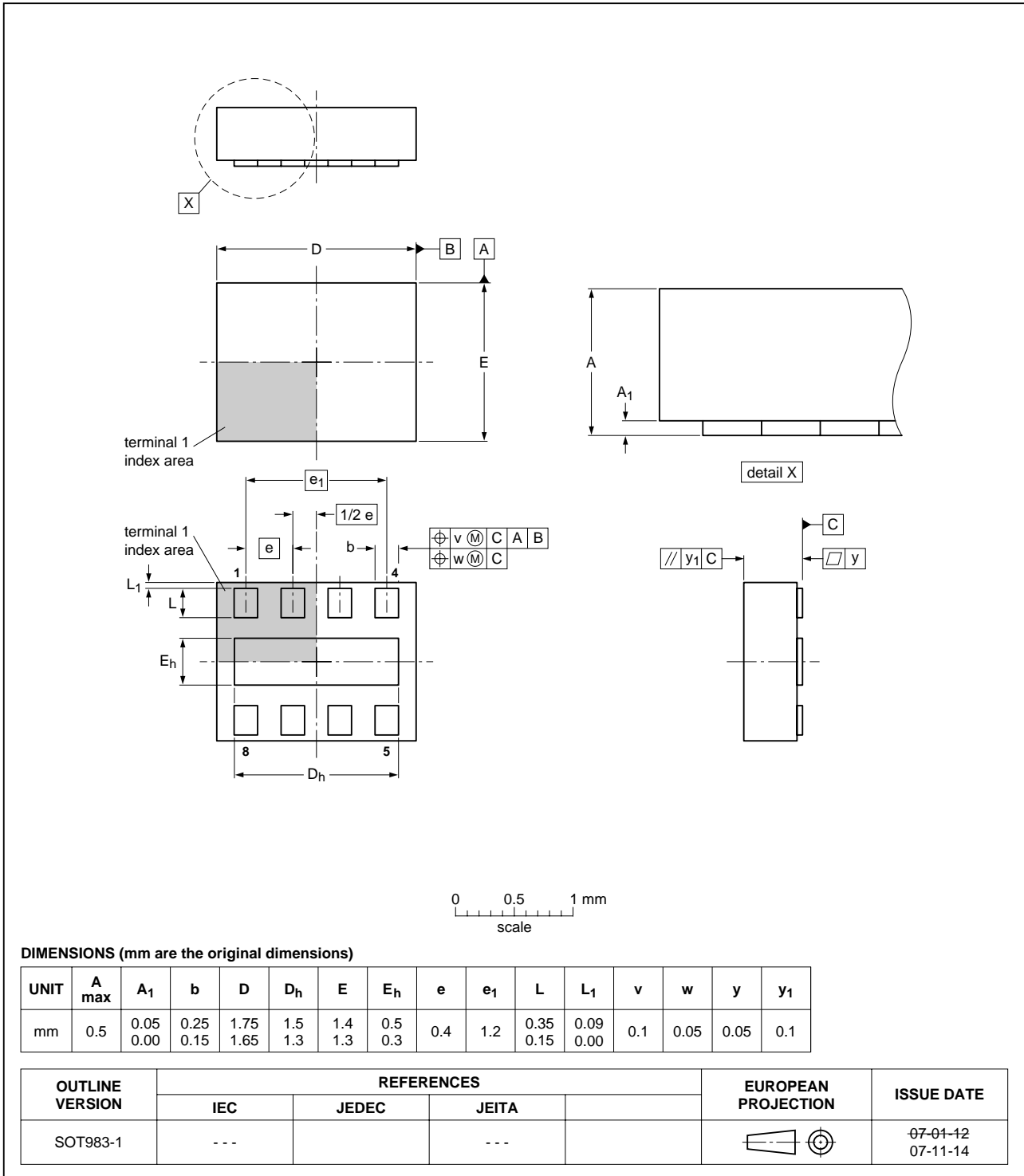

Fig 4. Package outline SOT983-1 (HXSON8U)

HXSON12U: plastic thermal enhanced extremely thin small outline package; no leads; 12 terminals; UTLP based; body 1.35 x 2.5 x 0.5 mm

SOT984-1

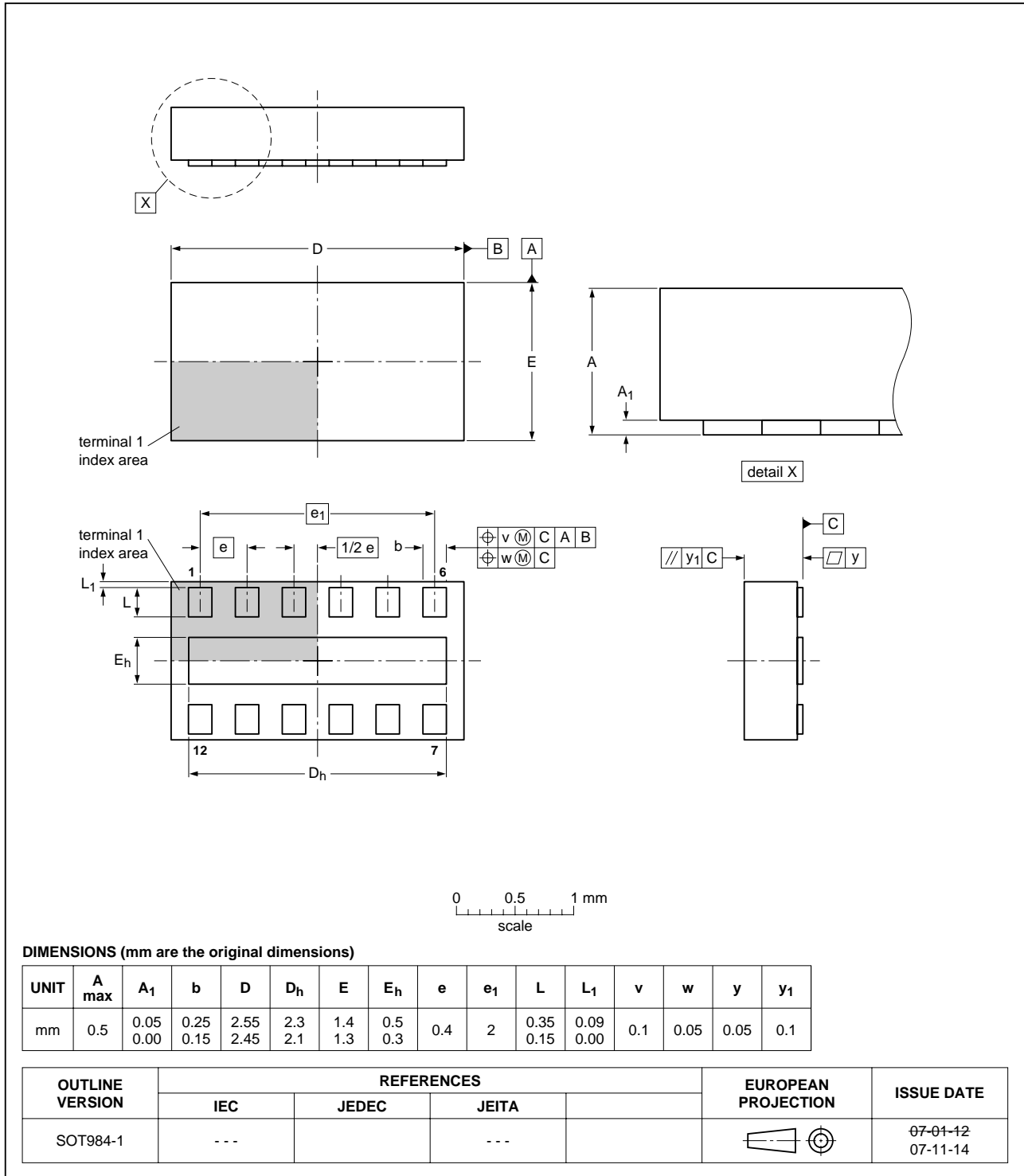

Fig 5. Package outline SOT984-1 (HXSON12U)

HXSON16U: plastic thermal enhanced extremely thin small outline package; no leads; 16 terminals; UTLP based; body 1.35 x 3.3 x 0.5 mm

SOT985-1

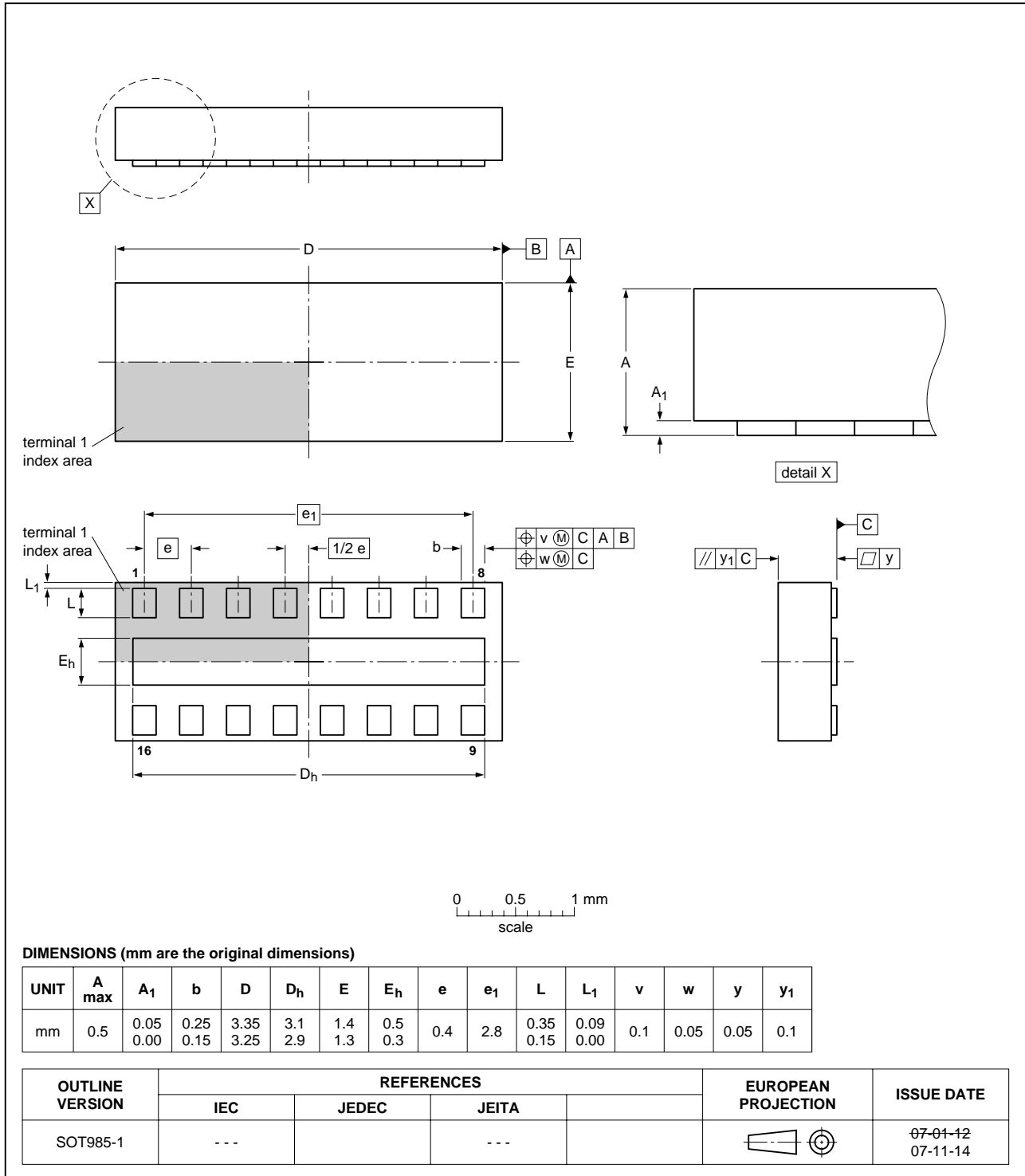

Fig 6. Package outline SOT985-1 (HXSON16U)

## 8. Abbreviations

Table 6. Abbreviations

Acronym	Description
EMI	ElectroMagnetic Interference
ESD	ElectroStatic Discharge
LAN	Local Area Network
PCB	Printed-Circuit Board
PCS	Personal Communication System
QFN	Quad Flat No leads
RFI	Radio Frequency Interference
RoHS	Restriction of Hazardous Substances
UTLP	Ultra-Thin Leadless Package
WAN	Wide Area Network

## 9. Revision history

Table 7. Revision history

Document ID	Release date	Data sheet status	Change notice	Supersedes
IP3253CZ8_CZ12_CZ16_2	20091016	Objective data sheet	-	IP3253CZ8_CZ12_CZ16_1
Modifications:				
<ul style="list-style-type: none"> <li>• Various minor textual inconsistencies in the data sheet corrected.</li> <li>• Changed <a href="#">Table 5</a>: <math>\alpha_{il}</math> insertion loss 1 GHz &lt; <math>f_i</math> &lt; 3 GHz to 1 GHz &lt; <math>f_i</math> &lt; 4 GHz.</li> <li>• Changed <a href="#">Table 5</a>: <math>f_{-3dB}</math> cut-off frequency Typ value from 275 MHz to 175 MHz.</li> <li>• Changed <a href="#">Table 5</a>: <math>f_{roll-off}</math> roll-off frequency Typ value from 400 MHz to 370 MHz.</li> <li>• Replaced <a href="#">Section 6: Figure 2 on page 5</a>.</li> <li>• Added <a href="#">Section 6: Figure 3 on page 5</a>.</li> </ul>				
IP3253CZ8_CZ12_CZ16_1	20090514	Objective data sheet	-	-

## 10. Legal information

### 10.1 Data sheet status

Document status <sup>[1][2]</sup>	Product status <sup>[3]</sup>	Definition
Objective [short] data sheet	Development	This document contains data from the objective specification for product development.
Preliminary [short] data sheet	Qualification	This document contains data from the preliminary specification.
Product [short] data sheet	Production	This document contains the product specification.

[1] Please consult the most recently issued document before initiating or completing a design.

[2] The term 'short data sheet' is explained in section "Definitions".

[3] The product status of device(s) described in this document may have changed since this document was published and may differ in case of multiple devices. The latest product status information is available on the Internet at URL <http://www.nxp.com>.

### 10.2 Definitions

**Draft** — The document is a draft version only. The content is still under internal review and subject to formal approval, which may result in modifications or additions. NXP Semiconductors does not give any representations or warranties as to the accuracy or completeness of information included herein and shall have no liability for the consequences of use of such information.

**Short data sheet** — A short data sheet is an extract from a full data sheet with the same product type number(s) and title. A short data sheet is intended for quick reference only and should not be relied upon to contain detailed and full information. For detailed and full information see the relevant full data sheet, which is available on request via the local NXP Semiconductors sales office. In case of any inconsistency or conflict with the short data sheet, the full data sheet shall prevail.

### 10.3 Disclaimers

**General** — Information in this document is believed to be accurate and reliable. However, NXP Semiconductors does not give any representations or warranties, expressed or implied, as to the accuracy or completeness of such information and shall have no liability for the consequences of use of such information.

**Right to make changes** — NXP Semiconductors reserves the right to make changes to information published in this document, including without limitation specifications and product descriptions, at any time and without notice. This document supersedes and replaces all information supplied prior to the publication hereof.

**Suitability for use** — NXP Semiconductors products are not designed, authorized or warranted to be suitable for use in medical, military, aircraft, space or life support equipment, nor in applications where failure or malfunction of an NXP Semiconductors product can reasonably be expected to result in personal injury, death or severe property or environmental

damage. NXP Semiconductors accepts no liability for inclusion and/or use of NXP Semiconductors products in such equipment or applications and therefore such inclusion and/or use is at the customer's own risk.

**Applications** — Applications that are described herein for any of these products are for illustrative purposes only. NXP Semiconductors makes no representation or warranty that such applications will be suitable for the specified use without further testing or modification.

**Limiting values** — Stress above one or more limiting values (as defined in the Absolute Maximum Ratings System of IEC 60134) may cause permanent damage to the device. Limiting values are stress ratings only and operation of the device at these or any other conditions above those given in the Characteristics sections of this document is not implied. Exposure to limiting values for extended periods may affect device reliability.

**Terms and conditions of sale** — NXP Semiconductors products are sold subject to the general terms and conditions of commercial sale, as published at <http://www.nxp.com/profile/terms>, including those pertaining to warranty, intellectual property rights infringement and limitation of liability, unless explicitly otherwise agreed to in writing by NXP Semiconductors. In case of any inconsistency or conflict between information in this document and such terms and conditions, the latter will prevail.

**No offer to sell or license** — Nothing in this document may be interpreted or construed as an offer to sell products that is open for acceptance or the grant, conveyance or implication of any license under any copyrights, patents or other industrial or intellectual property rights.

**Export control** — This document as well as the item(s) described herein may be subject to export control regulations. Export might require a prior authorization from national authorities.

### 10.4 Trademarks

Notice: All referenced brands, product names, service names and trademarks are the property of their respective owners.

## 11. Contact information

For more information, please visit: <http://www.nxp.com>

For sales office addresses, please send an email to: [salesaddresses@nxp.com](mailto:salesaddresses@nxp.com)

## 12. Contents

<b>1</b>	<b>Product profile</b> .....	<b>1</b>
1.1	General description .....	1
1.2	Features .....	1
1.3	Applications .....	1
<b>2</b>	<b>Pinning information</b> .....	<b>2</b>
<b>3</b>	<b>Ordering information</b> .....	<b>3</b>
<b>4</b>	<b>Limiting values</b> .....	<b>3</b>
<b>5</b>	<b>Characteristics</b> .....	<b>4</b>
<b>6</b>	<b>Application information</b> .....	<b>4</b>
6.1	Insertion loss .....	4
<b>7</b>	<b>Package outline</b> .....	<b>6</b>
<b>8</b>	<b>Abbreviations</b> .....	<b>9</b>
<b>9</b>	<b>Revision history</b> .....	<b>9</b>
<b>10</b>	<b>Legal information</b> .....	<b>10</b>
10.1	Data sheet status .....	10
10.2	Definitions .....	10
10.3	Disclaimers .....	10
10.4	Trademarks .....	10
<b>11</b>	<b>Contact information</b> .....	<b>10</b>
<b>12</b>	<b>Contents</b> .....	<b>11</b>



Please be aware that important notices concerning this document and the product(s) described herein, have been included in section 'Legal information'.

© NXP B.V. 2009.

All rights reserved.

For more information, please visit: <http://www.nxp.com>

For sales office addresses, please send an email to: [salesaddresses@nxp.com](mailto:salesaddresses@nxp.com)

Date of release: 16 October 2009

Document identifier: IP3253CZ8\_CZ12\_CZ16\_2