

DATA SHEET

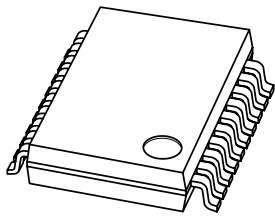

PESD5V2S18U ESD protection array

Product data sheet

2003 Apr 28

ESD protection array

PESD5V2S18U

FEATURES

- Uni-directional ESD protection of up to 18 lines
- Maximum peak reverse power: $P_{PP} = 100\text{ W}$ at $t_p = 8/20\ \mu\text{s}$
- Low clamping voltage: $V_{CL} = 12\text{ V}$ max. at $I_{ZSM} = 10\text{ A}$
- Low leakage current: $I_R = 100\text{ nA}$ typ. at $V_{RWM} = 5.2\text{ V}$
- IEC 61000-4-2, level 4 (ESD); 15 kV (air) and 8 kV (contact).

APPLICATIONS

- Printer parallel ports
- Computers and peripherals
- Communication systems.

DESCRIPTION

Monolithic ESD protection device designed to protect up to 18 transmission or data lines from the damage caused by electrostatic discharge (ESD) and surge pulses.

PINNING

PIN	DESCRIPTION
1 to 5	cathode (k1 to k5)
6 and 16	common anode (a1; a2)
7 to 15	cathode (k6 to k14)
17 to 20	cathode (k15 to k18)

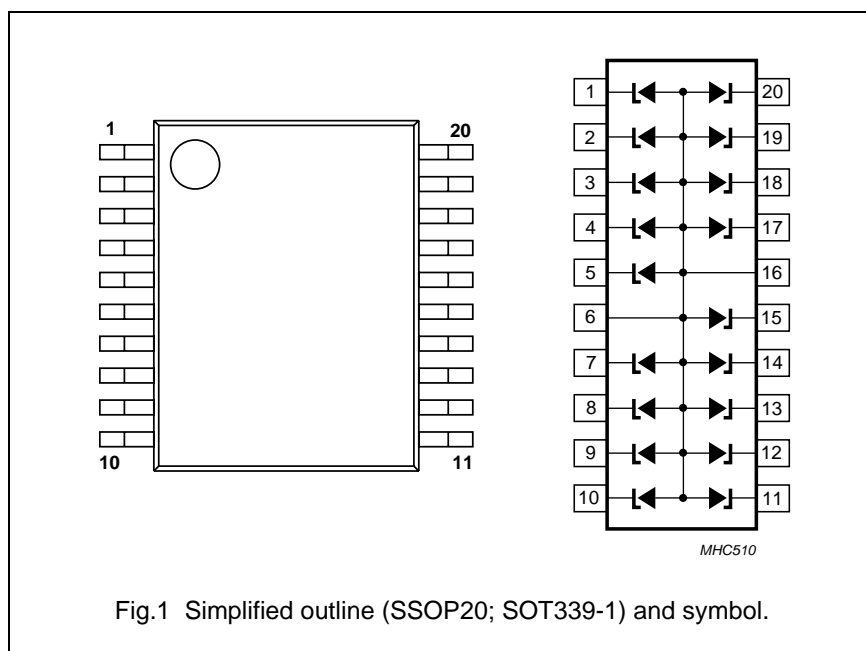

Fig.1 Simplified outline (SSOP20; SOT339-1) and symbol.

LIMITING VALUES

In accordance with the Absolute Maximum Rating System (IEC 60134).

SYMBOL	PARAMETER	CONDITIONS	MIN.	MAX.	UNIT
I_{PP}	non-repetitive peak reverse current	$t_p = 8/20\ \mu\text{s}$	–	10	A
P_{PP}	non-repetitive peak reverse power dissipation	$t_p = 8/20\ \mu\text{s}$	–	100	W
T_{stg}	storage temperature		–65	+150	°C
T_j	junction temperature		–65	+150	°C
	electrostatic discharge voltage	IEC 61000-4-2 (contact discharge)	30	–	kV
		HBM MIL-Std 883	10	–	kV

ESD standards compliance

IEC 61000-4-2, level 4 (ESD)	>15 kV (air); >8 kV (contact)
HBM MIL-Std 883, class 3	>4 kV

ESD protection array

PESD5V2S18U

THERMAL CHARACTERISTICS

SYMBOL	PARAMETER	CONDITIONS	VALUE	UNIT
$R_{th\ j-a}$	thermal resistance from junction to ambient	one or more diodes loaded	135	K/W

Note

1. Refer to SOT339-1 standard mounting conditions.

ELECTRICAL CHARACTERISTICS

$T_{amb} = 25\text{ }^{\circ}\text{C}$ unless otherwise specified.

SYMBOL	PARAMETER	CONDITIONS	MIN.	TYP.	MAX.	UNIT
V_{RWM}	crest working reverse voltage		–	–	5.2	V
I_R	reverse current	$V_{RWM} = 5.2\text{ V}$	–	0.1	1	μA
V_{CL}	clamping voltage	$I_{ZSM} = 3\text{ A}; t_p = 8/20\ \mu\text{s}; \text{ see Fig.5}$	–	–	8	V
		$I_{ZSM} = 10\text{ A}; t_p = 8/20\ \mu\text{s}; \text{ see Fig.5}$	–	–	12	V
V_{BR}	breakdown voltage	$I_Z = 5\text{ mA}$	6.4	6.8	7.2	V
r_{diff}	differential resistance	$I_Z = 1\text{ mA}$	–	–	40	Ω
		$I_Z = 5\text{ mA}$	–	–	8	Ω
C_d	diode capacitance	$V_R = 0; f = 1\text{ MHz}; \text{ see Fig.4}$	–	100	–	pF

ESD protection array

PESD5V2S18U

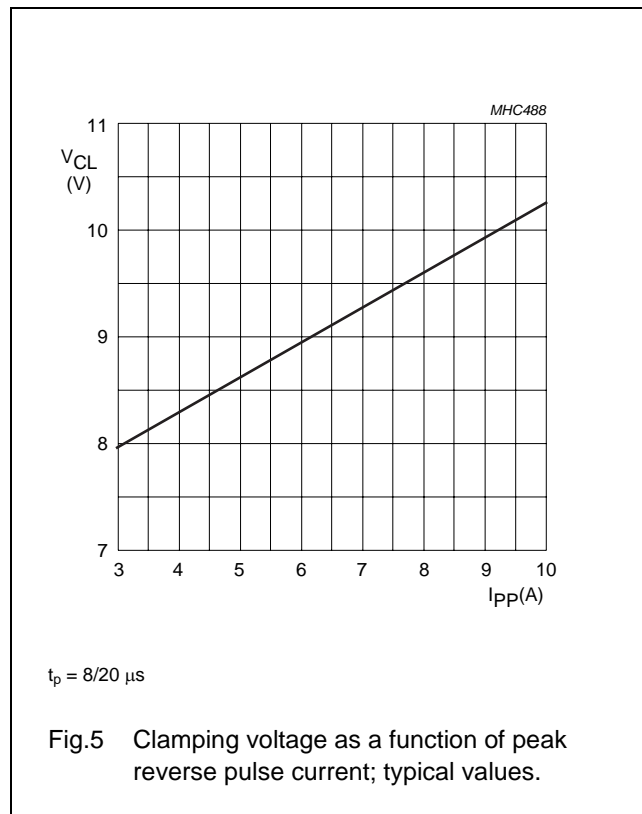
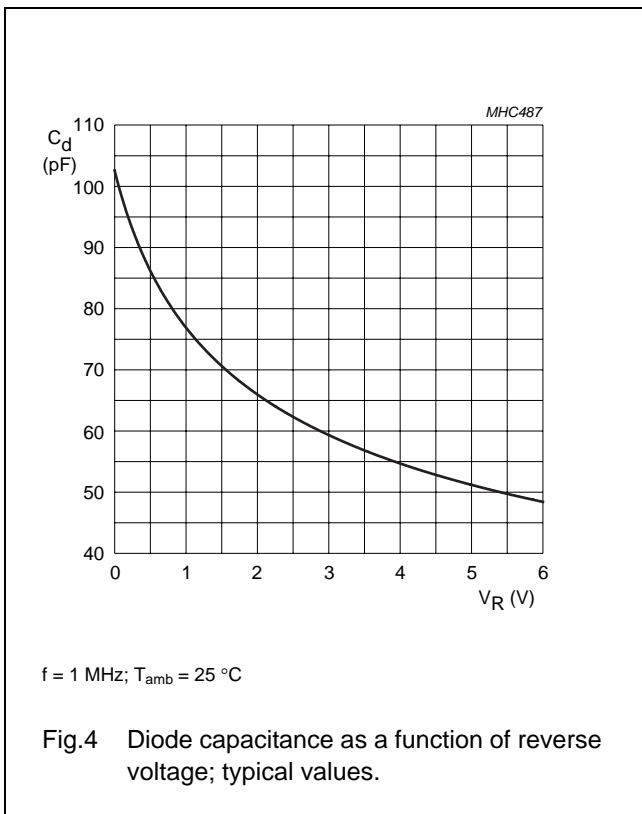
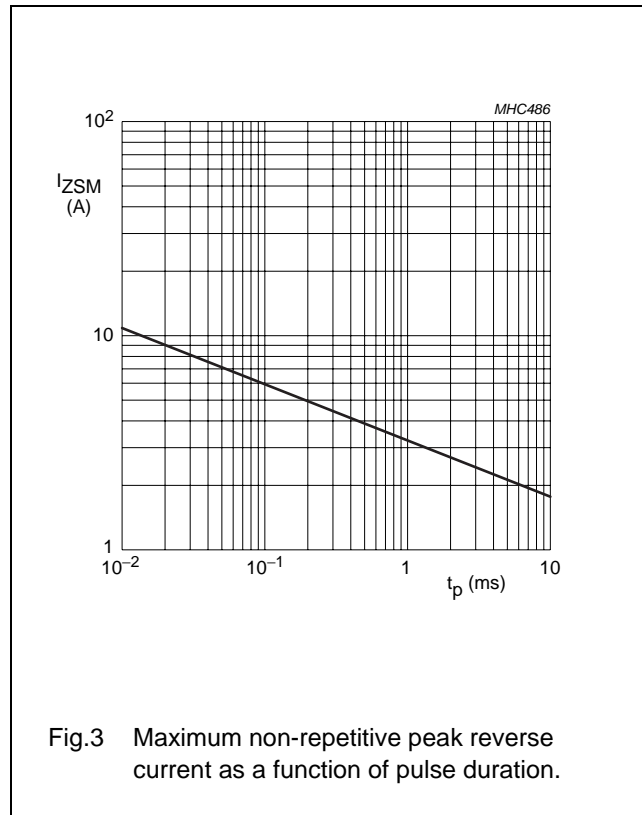
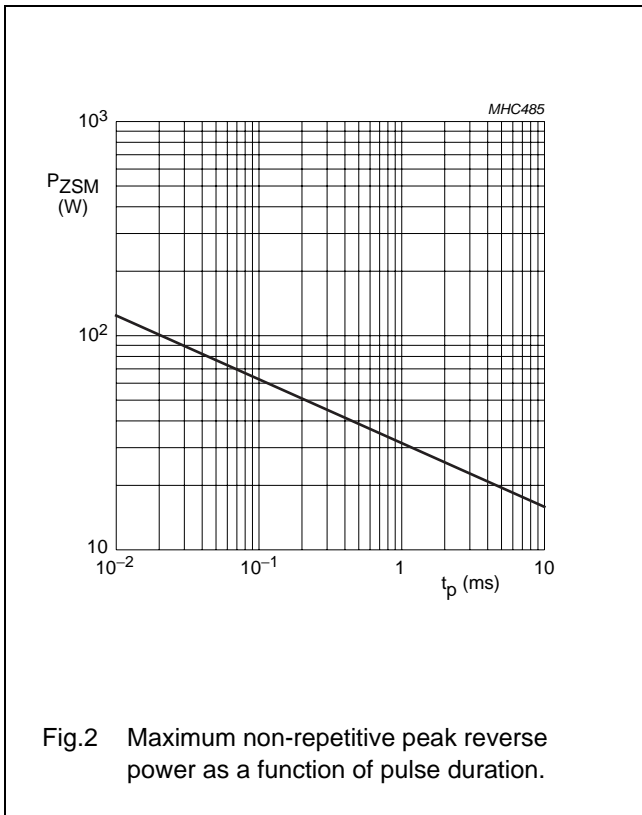

ESD protection array

PESD5V2S18U

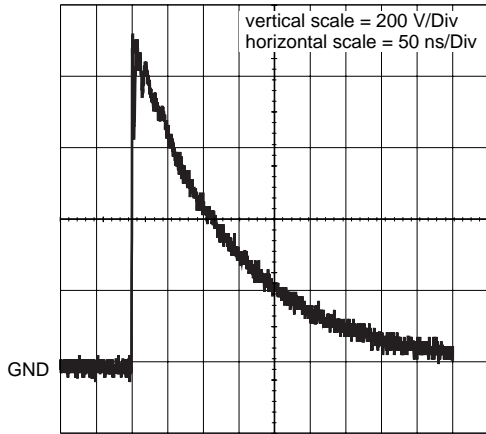
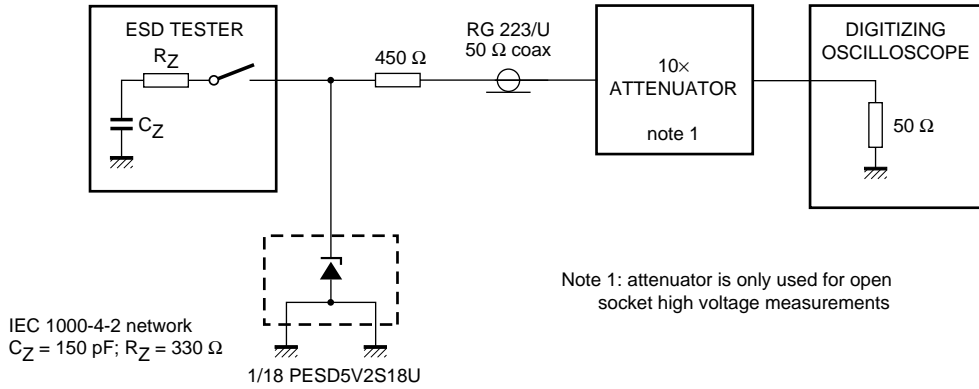

unclamped +1 kV ESD voltage waveform (IEC 1000-4-2 network)

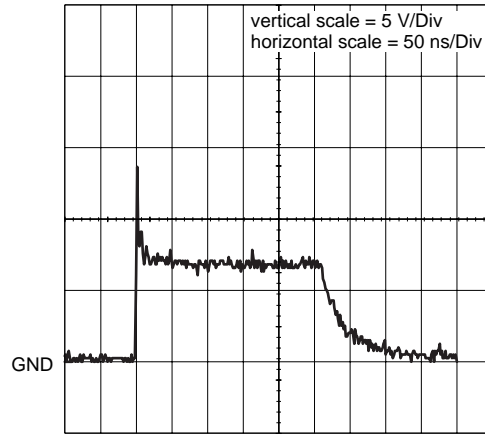

clamped +1 kV ESD voltage waveform (IEC 1000-4-2 network)

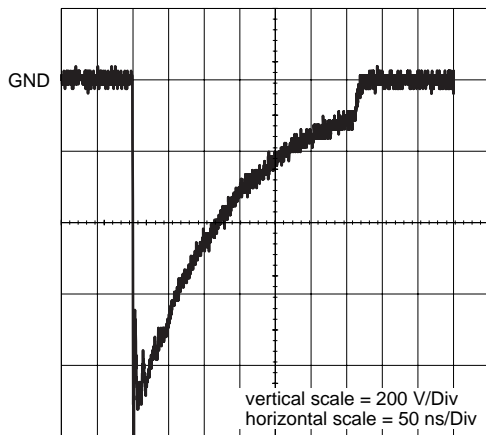

unclamped -1 kV ESD voltage waveform (IEC 1000-4-2 network)

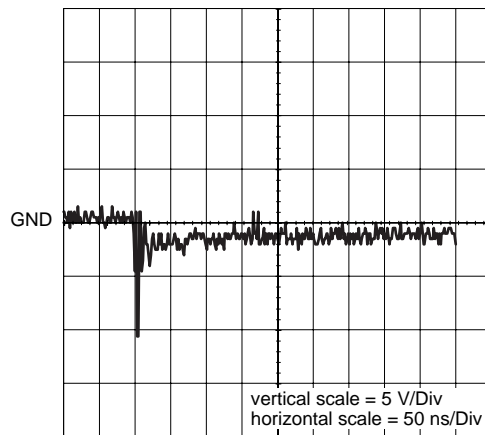

clamped -1 kV ESD voltage waveform (IEC 1000-4-2 network)

MHC489

Fig.6 ESD clamping test set-up and waveforms.

ESD protection array

PESD5V2S18U

PACKAGE OUTLINE

SSOP20: plastic shrink small outline package; 20 leads; body width 5.3 mm

SOT339-1

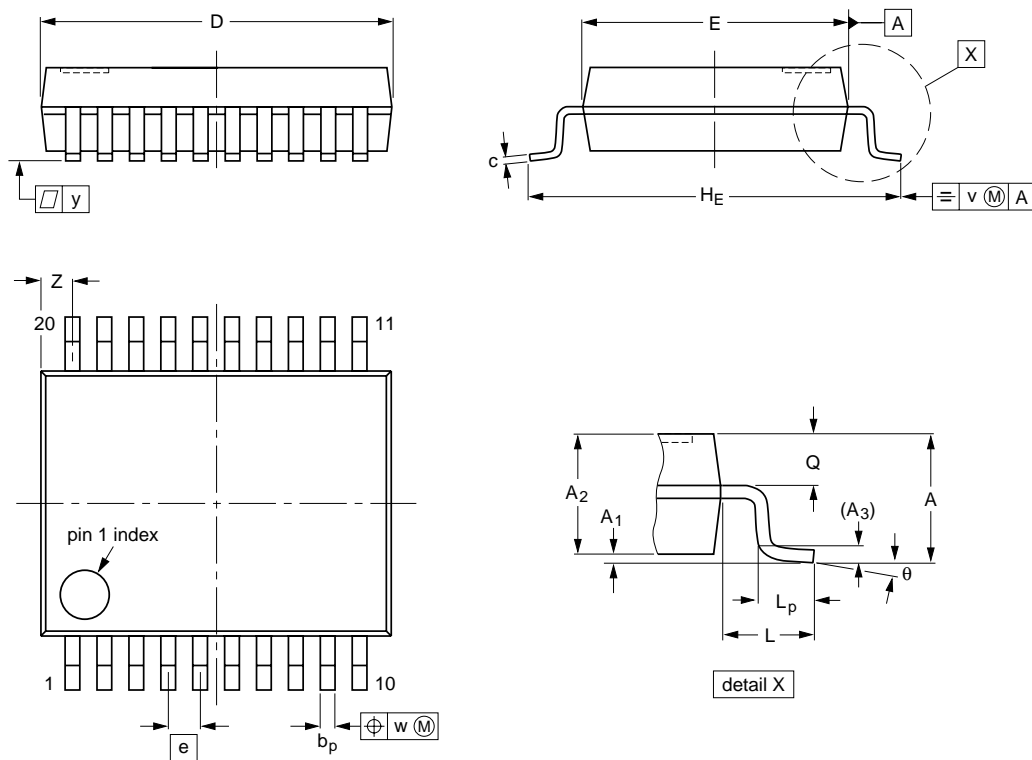

DIMENSIONS (mm are the original dimensions)

UNIT	A max.	A ₁	A ₂	A ₃	b _p	c	D ⁽¹⁾	E ⁽¹⁾	e	H _E	L	L _p	Q	v	w	y	z ⁽¹⁾	θ
mm	2	0.21 0.05	1.80 1.65	0.25	0.38 0.25	0.20 0.09	7.4 7.0	5.4 5.2	0.65	7.9 7.6	1.25	1.03 0.63	0.9 0.7	0.2	0.13	0.1	0.9 0.5	8° 0°

Note

1. Plastic or metal protrusions of 0.2 mm maximum per side are not included.

OUTLINE VERSION	REFERENCES				EUROPEAN PROJECTION	ISSUE DATE
	IEC	JEDEC	JEITA			
SOT339-1		MO-150				99-12-27 03-02-19

ESD protection array

PESD5V2S18U

DATA SHEET STATUS

DOCUMENT STATUS ⁽¹⁾	PRODUCT STATUS ⁽²⁾	DEFINITION
Objective data sheet	Development	This document contains data from the objective specification for product development.
Preliminary data sheet	Qualification	This document contains data from the preliminary specification.
Product data sheet	Production	This document contains the product specification.

Notes

1. Please consult the most recently issued document before initiating or completing a design.
2. The product status of device(s) described in this document may have changed since this document was published and may differ in case of multiple devices. The latest product status information is available on the Internet at URL <http://www.nxp.com>.

DISCLAIMERS

General — Information in this document is believed to be accurate and reliable. However, NXP Semiconductors does not give any representations or warranties, expressed or implied, as to the accuracy or completeness of such information and shall have no liability for the consequences of use of such information.

Right to make changes — NXP Semiconductors reserves the right to make changes to information published in this document, including without limitation specifications and product descriptions, at any time and without notice. This document supersedes and replaces all information supplied prior to the publication hereof.

Suitability for use — NXP Semiconductors products are not designed, authorized or warranted to be suitable for use in medical, military, aircraft, space or life support equipment, nor in applications where failure or malfunction of an NXP Semiconductors product can reasonably be expected to result in personal injury, death or severe property or environmental damage. NXP Semiconductors accepts no liability for inclusion and/or use of NXP Semiconductors products in such equipment or applications and therefore such inclusion and/or use is at the customer's own risk.

Applications — Applications that are described herein for any of these products are for illustrative purposes only. NXP Semiconductors makes no representation or warranty that such applications will be suitable for the specified use without further testing or modification.

Limiting values — Stress above one or more limiting values (as defined in the Absolute Maximum Ratings System of IEC 60134) may cause permanent damage to

the device. Limiting values are stress ratings only and operation of the device at these or any other conditions above those given in the Characteristics sections of this document is not implied. Exposure to limiting values for extended periods may affect device reliability.

Terms and conditions of sale — NXP Semiconductors products are sold subject to the general terms and conditions of commercial sale, as published at <http://www.nxp.com/profile/terms>, including those pertaining to warranty, intellectual property rights infringement and limitation of liability, unless explicitly otherwise agreed to in writing by NXP Semiconductors. In case of any inconsistency or conflict between information in this document and such terms and conditions, the latter will prevail.

No offer to sell or license — Nothing in this document may be interpreted or construed as an offer to sell products that is open for acceptance or the grant, conveyance or implication of any license under any copyrights, patents or other industrial or intellectual property rights.

Export control — This document as well as the item(s) described herein may be subject to export control regulations. Export might require a prior authorization from national authorities.

Quick reference data — The Quick reference data is an extract of the product data given in the Limiting values and Characteristics sections of this document, and as such is not complete, exhaustive or legally binding.

NXP Semiconductors

Customer notification

This data sheet was changed to reflect the new company name NXP Semiconductors. No changes were made to the content, except for the legal definitions and disclaimers.

Contact information

For additional information please visit: **<http://www.nxp.com>**

For sales offices addresses send e-mail to: **salesaddresses@nxp.com**

© NXP B.V. 2009

All rights are reserved. Reproduction in whole or in part is prohibited without the prior written consent of the copyright owner.

The information presented in this document does not form part of any quotation or contract, is believed to be accurate and reliable and may be changed without notice. No liability will be accepted by the publisher for any consequence of its use. Publication thereof does not convey nor imply any license under patent- or other industrial or intellectual property rights.

Printed in The Netherlands

613514/01/pp8

Date of release: 2003 Apr 28

Document order number: 9397 750 10889

