



# PIP8000FHN

## PMBus compliant digital power supervisor

Rev. 02 — 6 July 2009

Preliminary data sheet

## 1. General description

---

The PIP8000FHN is a Power Management Bus (PMBus) protocol compliant, digital power supervisor IC, configurable through a host system to meet dynamic converter performance for a multitude of power supply applications. It is also able to manage power supply operating conditions as well as to monitor and report the status back to a host system using the PMBus protocol.

The PMBus standard uses the widely accepted Inter-Integrated Circuit (I<sup>2</sup>C) communication protocol for the hardware interface. A number of additional features are added to enhance the basic I<sup>2</sup>C communication protocol. These are described in the System Management Bus (SMBus) protocol and include SMAAlert.

## 2. Features

---

- PMBus serial interface:
  - ◆ Query I/O voltage, I/O current, warnings, faults
  - ◆ Query temperature for up to two temperature sensors
  - ◆ Configure and measure RPM for up to two fans
  - ◆ Sequence start-up and turn-off
- Configurable 7-channel A/D with calibration factors
- I<sup>2</sup>C device-address pin stripping
- Compatible with most analog controllers
- Power-on reset
- I<sup>2</sup>C-bus up to 400 kHz
- 2.4 V to 3.6 V V<sub>DD</sub> operating range
- 5 V tolerant I/O pins
- Thermal sense capabilities
- 28 pin HVQFN package, 6 mm × 6 mm

## 3. Applications

---

- PMBus compliant low voltage, high current density applications
- DC power distributed systems
- Networking applications
- Servers and server accessories
- Telecommunication systems
- Industrial / ATE power applications
- Storage systems

- AC/DC and DC-to-DC applications

## 4. Ordering information

Table 1. Ordering information

Type number	Package		Version
	Name	Description	
PIP8000FHN/N1	HVQFN28	plastic thermal enhanced very thin quad flat package; no leads; 28 terminals; body 6 × 6 × 0.85 mm	SOT788-1

## 5. Block diagram

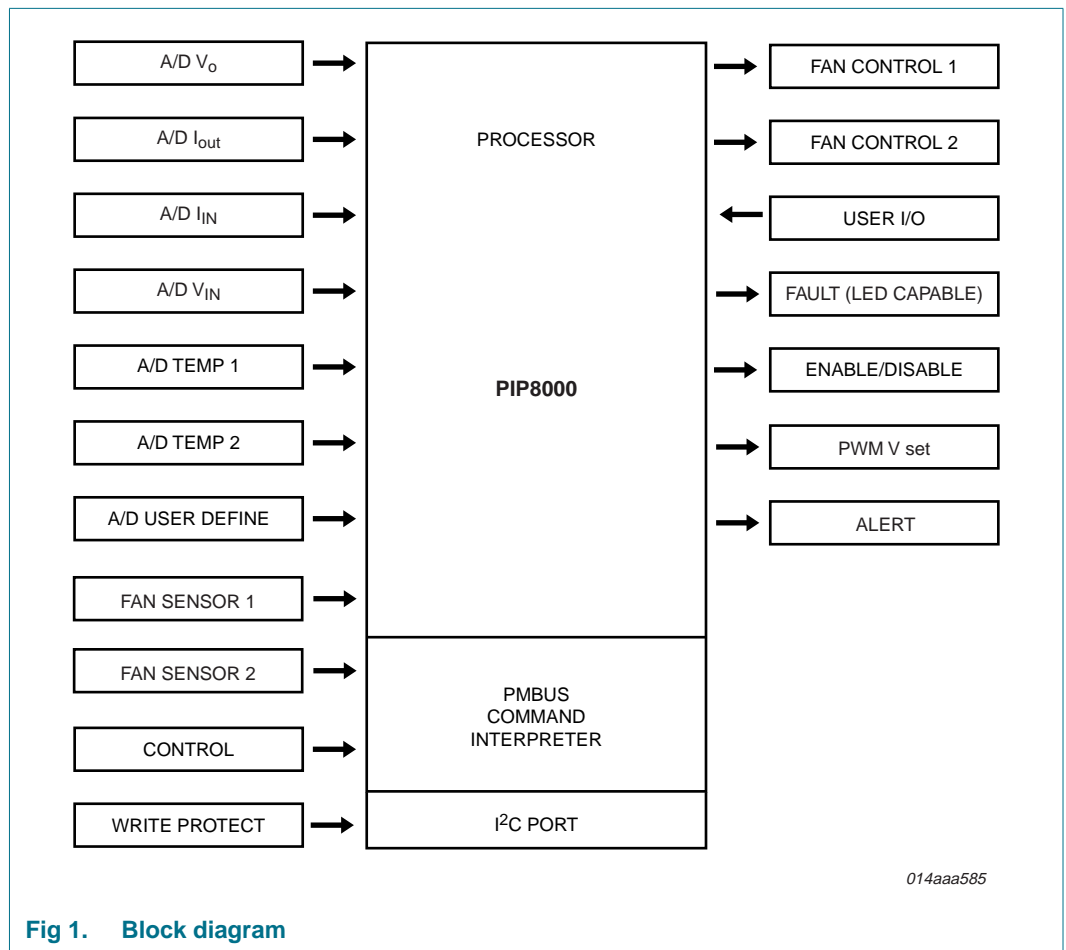
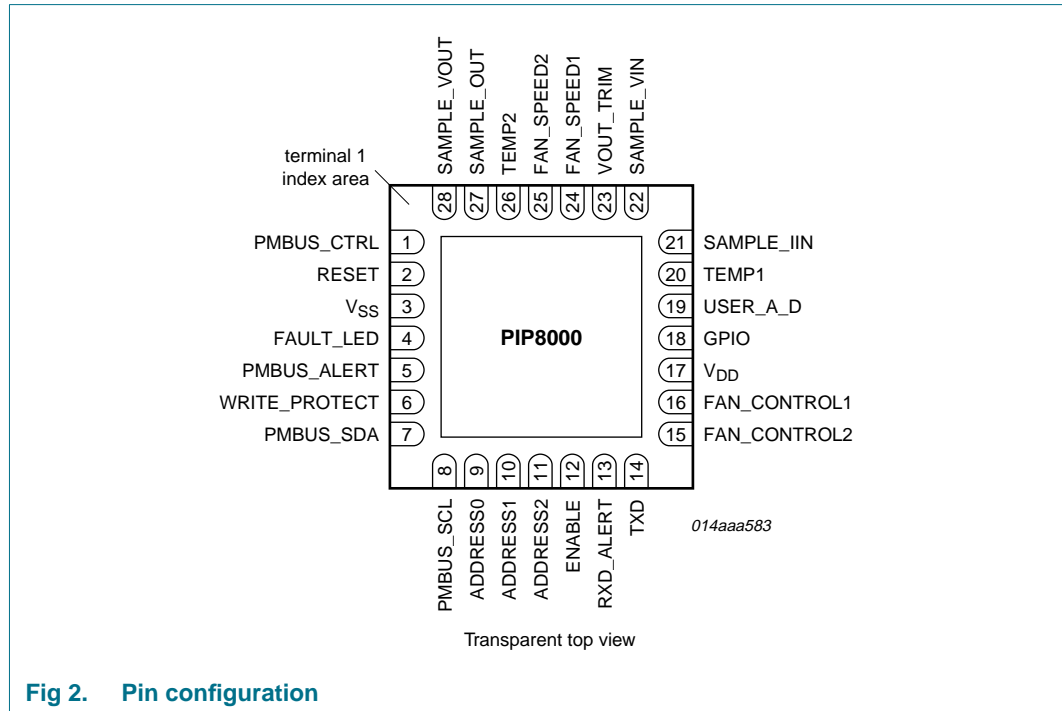

Fig 1. Block diagram

## 6. Pinning information

### 6.1 Pinning



### 6.2 Pin description

Table 2. Pin description

Symbol	Pin	Type	Description
PMBUS_CTRL	1	I	An input line from the host controller used to control the device in conjunction with commands over PMBus. Can be configured active HIGH or LOW through the ON_OFF_Config command.
RESET	2		Active LOW reset
V <sub>SS</sub>	3		Ground: 0 V reference.
FAULT_LED	4	O	User configurable. Used to enable/disable green/red LED.
PMBUS_ALERT	5	O	Interrupt line to SMBbus host controller
WRITE_PROTECT	6	I	When this pin is HIGH or n.c., only the PMBus command Write Protect can be read. Used to protect PoL data settings. Ground to Write.
PMBUS_SDA	7	I/O	Data and clock lines of the I <sup>2</sup> C/SMBus v 1.1 standard
PMBUS_SCL	8	I/O	Data and clock lines of the I <sup>2</sup> C/SMBus v 1.1 standard
ADDRESS0	9	O	I <sup>2</sup> C subaddress selection line 0
ADDRESS1	10	O	I <sup>2</sup> C subaddress selection line 1
ADDRESS2	11	O	I <sup>2</sup> C subaddress selection line 2

Table 2. Pin description ...continued

Symbol	Pin	Type	Description
ENABLE	12	O	A default but configurable pin dedicated to controlling the on/off operation of the power train. May be set either HIGH or LOW to enable.
RXD_ALERT	13	O	
TXD	14	O	
FAN_CONTROL2	15	O	User configurable active HIGH/LOW fan 1 on off.
FAN_CONTROL1	16	O	User configurable active HIGH/LOW fan 2 on off.
V <sub>DD</sub>	17		This is the power supply for normal operation as well as Idle mode and Power-down mode.
GPIO	18	I/O	General Purpose Input/Output
User_A_D	19	I	Readable User A/D. Coefficients can be set for a particular calibration/scale factor configuration.
TEMP1	20	I	Common analog temperature sensors connection, the output of which is typically 25 mV / °C. Coefficients can be set for a particular calibration/scale factor configuration.
SAMPLE_IIN	21	I	Current sense amplifier connection. Coefficients can be set for a particular calibration/scale factor configuration.
SAMPLE_VIN	22	I	Connection for either directly to V <sub>IN</sub> if less than V <sub>DD</sub> or through a resistor divider if higher than V <sub>DD</sub> . Coefficients can be set for a particular calibration/scale factor configuration.
VOUT_TRIM	23	O	This is a 20 kHz PWM square wave with a duty cycle that is directly controlled by the PMBus V <sub>out</sub> command. This waveform is externally integrated to develop a DC level, buffered, and then driven through a series scaling resistor to become a current source into the analog controller voltage feedback pin, which then changes the output voltage of the power train. The scaling resistor can scale the duty cycle change at pin 23 so that the power train output voltage may be varied from V to mV. Coefficients can be set for a particular calibration/scale factor configuration.
FAN_SPEED1, FAN_SPEED2	24, 25	I	Read-only pins connected as a 16-bit counter and used to count fan RPM in certain applications. This requires fans with three-pin wiring.
TEMP2	26	I	See pin 20, TEMP1.
SAMPLE_IOUT	27	I	Current sense amp connection. Coefficients can be set for a particular calibration/scale factor configuration.
SAMPLE_VOUT	28	I	Connected either directly to V <sub>o</sub> if less than V <sub>DD</sub> or through a resistor divider if higher than V <sub>DD</sub> . Coefficients can be set for a particular calibration/scale factor configuration.

## 7. Functional description

### 7.1 System interfaces

There are several interfaces:

- PMBus - Two lines consisting of a serial clock and serial data, conforming to SMBus V. 2.0, including digital lines called control and one SMAAlert.
- Seven channels of 10-bit resolution A/D for measurement of temperatures and I/O volts and current with one channel user definable.
- Two channels of low frequency 16-bit counters for fan speed measurement.
- Pulse Width Modulation (PWM) output with 10 bits of duty cycle resolution for setting a DC level to adjust analog PWM controllers and hence the power supply output voltage.

### 7.2 Operations

PMBus defines that a compliant device must start and operate stably without PMBus communications. When a module implementing the PIP8000FHN is powered up, the PIP8000FHN goes through several levels of configuration, finishing by loading the end user operating parameters from NVRAM, measuring input voltage, checking the power train for proper operating environment and, when configured, enables the output voltage.

It may operate without any host interaction. If commanded, it can deliver status information. This will allow the host controller to collect data at the system designer's initiative, including long term data for system reliability purposes. Finally, it will issue warnings if operating margins are exceeded or perform selected actions if actual operating Fault limits are exceeded.

### 7.3 Product functions

- PMBus compliant, support commands are listed in [Table 10](#)
- Configurable overvoltage/undervoltage, overcurrent, and temperature protection
- Configurable response to fault events and warnings
- Configurable sequencing
- Wide range output voltage
- Configurable output voltage ramping
- Non-volatile memory for storing configuration values, device specifications, etc.

### 7.4 Host interface

The PIP8000FHN can run stand-alone or a host controller can be connected using the I<sup>2</sup>C interface. With a host controller the PIP8000FHN can be controlled and monitored using the PMBus commands as listed in [Section 10](#).

#### 7.4.1 I<sup>2</sup>C slave address

Any device that exists on the System Management Bus (SMB) as a slave has a unique address called the slave address. For reference, the following addresses are reserved and must not be used by or assigned to any SMBus slave device.

**Table 3. Overview slave addresses**

Slave address bits 7-1	R/W number bit bit 0	Description
0000 000	0	General call address
0000 000	1	START byte
0000 001	X	CBUS address
0000 010	X	Address reserved for different bus format
0000 011	X	Reserved for future use
0000 1XX	X	Reserved for future use
0101 000	X	Reserved for ACCESS.bus host
0110 111	X	Reserved for ACCESS.bus default address
1111 0XX	X	10-bit slave addressing
1111 1XX	X	Reserved for future use
0001 000	X	SMBus host
0001 100	X	SMBus alert response address
1100 001	X	SMBus device default address

The I<sup>2</sup>C slave address can be set using the manufacturer specific command I<sup>2</sup>C\_ADDRESS and pin stripping the I<sup>2</sup>C subaddress pins. When the I<sup>2</sup>C slave address is changed during operation the STORE\_DEFAULT\_ALL or STORE\_USER\_ALL command must be issued to save the I<sup>2</sup>C slave address in NVRAM and then a software reset needs to be issued to activate the new I<sup>2</sup>C address:

$$\text{I}^2\text{C address} = \text{I}^2\text{C\_ADDRESS} + (\text{pin strip bit}[\text{A}2]\text{bit}[\text{A}1]\text{bit}[\text{A}0] < 1)$$

If an invalid I<sup>2</sup>C\_ADDRESS is read from I<sup>2</sup>C during start-up the I<sup>2</sup>C address will be set to the SMBus device default address. And the CONFIG\_COMMAND bit[7] will be set. This bit indicates if the PMBus state machine will not start. This is done to prevent wrong coefficients or other configuration settings to be used in the PMBus state machine.

The LSB of I2ADR is the general call bit. When this bit is set, the general call address (00h) is recognized.

### 7.4.2 ALERT functionality

The PIP8000FHN supports the SMBus SMAAlert line. The alert protocol creates a method for an I<sup>2</sup>C slave device to signal the I<sup>2</sup>C host device. The host can identify the slave with the fault.

After signaling the host the PIP8000FHN will change its slave address to 0x18h (ARA). The host responds to the SMAAlert signal by reading a byte from 0x18h. The slave will respond with its original slave address and return to that address. The SMAAlert line can be used as a wired system or in a power supply system with multiple PIP8000FHN supervisor chips.

Fault and warning notification using SMAAlert can be configured as described in [Section 7.7](#).

**7.4.3 Packet Error Check (PEC)**

The PIP8000FHN supports SMBus PEC protocol dynamically. If a write command is sent including a PEC the PIP8000FHN will use it to determine if the command was received correctly. If no PEC is available it will check if the command is supported according to [Section 10.2](#) and processes it. If a read command is sent the PIP8000FHN will append the PEC byte when the host reads more bytes than the return data.

**7.4.4 Data formats**

The PIP8000FHN supports Linear mode and Direct mode data formats. These modes can be switched real time. However, they are typically selected at the beginning of the application and stored in NVRAM. [Table 4](#) shows which commands are affected by the mode setting. From the table it can be noted that three modes are supported:

- All data formats in Direct mode.
- All data in Linear mode not using VOUT\_MODE.
- All data in Linear mode using VOUT\_MODE for the VOUT related commands.

**Table 4. Modes for data formats**

VOUT_MODE	CONFIG_COMMAND	Mode
Don't care	Bit[1] = 0	Direct mode for all commands
bits[7...5] NOT 000	Bit[1] = 1	Linear mode NOT using VOUT_MODE 5-bit mantissa. Commands in Linear mode are: PMBUS_VOUT_COMMAND PMBUS_VOUT_MAX PMBUS_VOUT_MARGIN_HIGH PMBUS_VOUT_MARGIN_LOW PMBUS_READ_VOUT PMBUS_VOUT_TRIM PMBUS_VOUT_CAL_OFFSET PMBUS_VOUT_TRANSITION_RATE PMBUS_VOUT_SCALE_LOOP PMBUS_VOUT_SCALE_MONITOR PMBUS_VOUT_OV_FAULT_LIMIT PMBUS_VOUT_OV_WARN_LIMIT PMBUS_VOUT_UV_WARN_LIMIT PMBUS_VOUT_UV_FAULT_LIMIT PMBUS_READ_IOUT PMBUS_IOUT_CAL_GAIN PMBUS_IOUT_CAL_GAIN PMBUS_IOUT_CAL_OFFSET PMBUS_IOUT_OC_FAULT_LIMIT PMBUS_IOUT_OC_LV_FAULT_LIMIT PMBUS_IOUT_OC_WARN_LIMIT PMBUS_READ_VIN PMBUS_VIN_ON

Table 4. Modes for data formats ...continued

VOUT_MODE	CONFIG_COMMAND	Mode
		PMBUS_VIN_OFF
		PMBUS_VIN_OV_FAULT_LIMIT
		PMBUS_VIN_OV_WARN_LIMIT
		PMBUS_VIN_UV_WARN_LIMIT
		PMBUS_VIN_UV_FAULT_LIMIT
		PMBUS_READ_IIN
		PMBUS_IIN_OC_FAULT_LIMIT
		PMBUS_IIN_OC_WARN_LIMIT
		PMBUS_READ_TEMPERATURE_1
		PMBUS_OT_FAULT_LIMIT
		PMBUS_OT_WARN_
		PMBUS_READ_TEMPERATURE_
		PMBUS_READ_USER_AD
Linear bits[7..5] 000	Bit[1] = 1	<p>Linear mode using VOUT_MODE 5 bit mantissa.            Commands in Linear mode for:</p> <p>PMBUS_VOUT_COMMAND</p> <p>PMBUS_VOUT_MAX</p> <p>PMBUS_VOUT_MARGIN_HIGH</p> <p>PMBUS_VOUT_MARGIN_LOW</p> <p>PMBUS_READ_VOUT</p> <p>PMBUS_READ_VOUT</p> <p>PMBUS_VOUT_TRIM</p> <p>PMBUS_VOUT_CAL_OFFSET</p> <p>PMBUS_VOUT_TRANSITION_RATE</p> <p>PMBUS_VOUT_SCALE_LOOP</p> <p>PMBUS_VOUT_SCALE_MONITOR</p> <p>PMBUS_VOUT_OV_FAULT_LIMIT</p> <p>PMBUS_VOUT_OV_WARN_LIMIT</p> <p>PMBUS_VOUT_UV_WARN_LIMIT</p> <p>PMBUS_VOUT_UV_FAULT_LIMIT</p>
		<p>Linear mode NOT using VOUT_MODE 5 bit mantissa (normal linear_mode):</p> <p>PMBUS_READ_IOUT</p> <p>PMBUS_IOUT_CAL_GAIN</p> <p>PMBUS_IOUT_CAL_OFFSET</p> <p>PMBUS_IOUT_OC_FAULT_LIMIT</p> <p>PMBUS_IOUT_OC_LV_FAULT_LIMIT</p> <p>PMBUS_IOUT_OC_WARN_LIMIT</p> <p>PMBUS_READ_VIN</p> <p>PMBUS_VIN_ON</p> <p>PMBUS_VIN_OFF</p>

Table 4. Modes for data formats ...continued

VOUT_MODE	CONFIG_COMMAND	Mode
		PMBUS_VIN_OV_FAULT_LIMIT
		PMBUS_VIN_OV_WARN_LIMIT
		PMBUS_VIN_UV_WARN_LIMIT
		PMBUS_VIN_UV_FAULT_LIMIT
		PMBUS_READ_IIN
		PMBUS_IIN_OC_FAULT_LIMIT
		PMBUS_IIN_OC_WARN_LIMIT
		PMBUS_READ_TEMPERATURE_1
		PMBUS_OT_FAULT_LIMIT
		PMBUS_OT_WARN_
		PMBUS_READ_TEMPERATURE_
		PMBUS_READ_USER_AD

7.4.5 Coefficients and query

The coefficients and query commands uses the block-write-block-read process call as described in the *SMBus specification, version 2.0*.

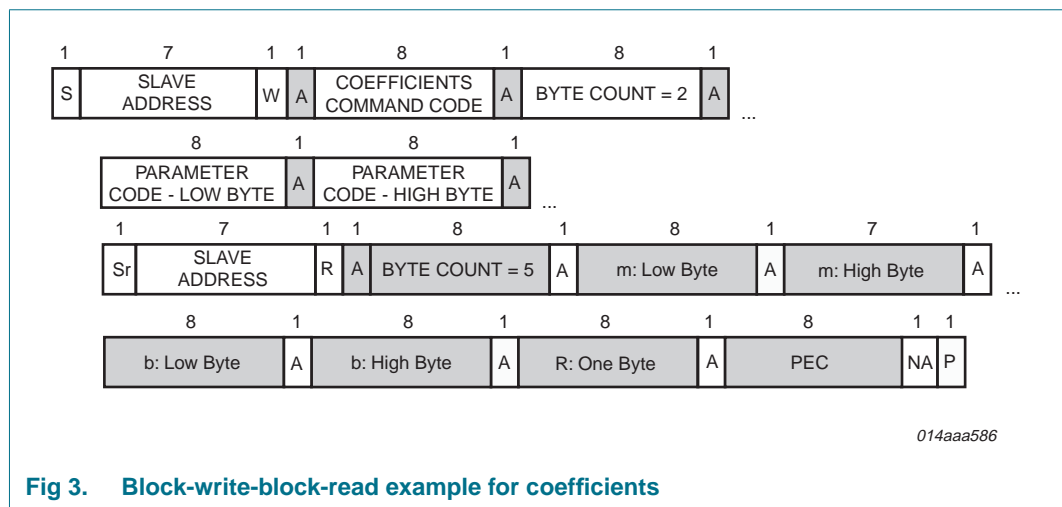

Fig 3. Block-write-block-read example for coefficients

7.5 Power-up /power-down

Controlling the power train can be accomplished in the following three ways:

- $V_{IN}$  controls power-up and power-down based on the  $V_{IN}$  value passing through required threshold,
- OPERATION and ON\_OFF\_CONFIG commands controls on/off switch of the power train.
- CTL-pin is the on/off switch. It can be configured to assert HIGH or LOW.

7.6 OPERATION and ON\_OFF\_CONFIG

PIP8000FHN supports the following power-up/power-down process. See [Table 5](#) and [Table 6](#).

- ON\_OFF\_CONFIG = 0x00: Power-up when V<sub>CC</sub> is valid. Uses OPERATION for margin and normal power-down.
- ON\_OFF\_CONFIG = 0x04: OPERATION controls everything for normal power-up/power-down.
- ON\_OFF\_CONFIG = [0x10, 0x11, 0x12, 0x13]: Control pin initiates everything except OPERATION-margin. 0x10, 0x11 are assert LOW and 0x12, 0x13 are assert HIGH.

**Table 5. ON\_OFF\_CONFIG**

ON_OFF_CONFIG	Hex
V <sub>IN</sub> > V <sub>IN_on</sub> = power-up; V <sub>IN</sub> < V <sub>IN_fault</sub> /V <sub>IN_off</sub> = power-down	0x00
OPERATION controls power-up/power-down	0x04
CTL on active LOW, soft off	0x10
CTL on active LOW, hard off	0x11
CTL on active HIGH, soft off	0x12
CTL on active HIGH, hard off	0x13

**Table 6. Operation**

Operation	Mask	Hex
Immediate OFF	& C0	0
Soft off	& C0	40
Unit on no margin	& F0	81
Margin low ignore fault	& FC	94
Margin low faults enabled	& FC	98
Margin high ignore fault	& FC	A4
Margin high fault enabled	& FC	A8

Margin-no-margin 0x(81,94, 98, A4, A8) always works, regardless of on\_off\_config setting.

## 7.7 ALERT\_CONFIG

The byte specifies for which fault condition the SMBus SMAAlert protocol will be initiated. This setting influences only the SMAAlert protocol and not the detection and handling of fault conditions by the PIP8000FHN. When set to 0x00 SMAAlert will not signal any condition. Bit fields are:

**Table 7. ALERT\_CONFIG**

Bits [7..0]	SMAAlert protocol used to signal
[0]	VOUT_UV_FAULT
[1]	VOUT_OV_FAULT
[2]	IOUT_OV_FAULT
[3]	TON_MAX_FAULT
[4]	VIN_OV_FAULT
[5]	VIN_UV_FAULT
[6]	IIN_OV_FAULT
[7]	OT_FAULT

## 8. Limiting values

**Table 8. Limiting values**

In accordance with the Absolute Maximum Rating System (IEC 60134).<sup>[1]</sup>

Symbol	Parameter	Conditions	Min	Max	Unit
$T_{amb}$	ambient temperature	operating bias	-55	+125	°C
$T_{stg}$	storage temperature		-65	+150	°C
$I_{OH}$	HIGH-level output current	per I/O pin	-	20	mA
$I_{OL}$	LOW-level output current	per I/O pin	-	20	mA
$I_{I/O(tot)(max)}$	maximum total I/O current	maximum total I/O current	-	100	mA
$P_{tot}$	total power dissipation	based on package heat transfer, not device power consumption	-	1.5	W

[1] The following applies to [Table 8](#):

- Stresses above those listed may cause permanent damage to the device. This is a stress rating only and functional operation of the device at these or any conditions other than those described in [Table 9](#), Characteristics and [Table 8](#), Limiting values of this specification are not implied.
- This product includes circuitry specifically designed for the protection of its internal devices from the damaging effects of excessive static charge. Nonetheless, it is suggested that conventional precautions will be taken to avoid exceeding the rated maximum.
- Parameters are valid over operating temperature range unless otherwise specified. All voltages are with respect to  $V_{SS}$  unless otherwise noted.

## 9. Characteristics

**Table 9. DC electrical characteristics**

$V_{DD} = 2.4\text{ V to }3.6\text{ V unless otherwise specified.}$

$T_{amb} = -40\text{ °C to }+85\text{ °C for industrial applications, unless otherwise specified.}$

Symbol	Parameter	Conditions	Min	Typ <sup>[1]</sup>	Max	Unit
$I_{DD}$	supply current	$V_{DD} = 3.6\text{ V}$	-	14	23	mA
		$V_{DD} = 3.6\text{ V, Idle mode}$	-	5	7	mA
		$V_{DD} = 3.6\text{ V, Power-down mode}$	-	55	80	μA
$I_{DD(tot)}$	total supply current	$V_{DD} = 3.6\text{ V, Power-down mode}$	<a href="#">[2]</a> -	1	5	μA
$(dV/dt)_r$	rise rate of change of voltage	of $V_{DD}$	-	-	2	mV/μs
$(dV/dt)_f$	fall rate of change of voltage	of $V_{DD}$	-	-	50	mV/μs
$V_{DDR}$	data retention voltage		1.5	-	-	V
$V_{th(HL)}$	HIGH to LOW threshold voltage	except SCL, SDA	$0.22V_{DD}$	$0.4V_{DD}$	-	V
$V_{IL}$	LOW-level input voltage	SCL, SDA only	-0.5	-	$0.3V_{DD}$	V
$V_{th(LH)}$	LOW to HIGH threshold voltage	except SCL, SDA	-	$0.6V_{DD}$	$0.7V_{DD}$	V
$V_{IH}$	HIGH-level input voltage	SCL, SDA only	$0.7V_{DD}$	-	5.5	V
$V_{hys}$	hysteresis voltage	port 1	-	$0.2V_{DD}$	-	V

**Table 9. DC electrical characteristics ...continued**

$V_{DD} = 2.4\text{ V to }3.6\text{ V unless otherwise specified.}$

$T_{amb} = -40\text{ }^{\circ}\text{C to }+85\text{ }^{\circ}\text{C for industrial applications, unless otherwise specified.}$

Symbol	Parameter	Conditions	Min	Typ <sup>[1]</sup>	Max	Unit
V <sub>OL</sub>	LOW-level output voltage	I <sub>OL</sub> = 20 mA; V <sub>DD</sub> = 2.4 V – 3.6 V; all ports; all modes except Hi-Z	[3] -	0.6	1.0	V
		I <sub>OL</sub> = 3.2 mA; V <sub>DD</sub> = 2.4 V – 3.6 V; all ports; all modes except Hi-Z	[3] -	0.2	0.3	V
V <sub>OH</sub>	HIGH-level output voltage	I <sub>OH</sub> = -20 μA; V <sub>DD</sub> = 2.4 V – 3.6 V; Quasi-bidirectional mode; all ports	V <sub>DD</sub> - 0.3	V <sub>DD</sub> - 0.2	-	V
		I <sub>OH</sub> = -3.2 mA; V <sub>DD</sub> = 2.4 V – 3.6 V; Push-pull mode; all ports	V <sub>DD</sub> - 0.7	V <sub>DD</sub> - 0.4	-	V
		I <sub>OH</sub> = -20 mA; V <sub>DD</sub> = 2.4 V – 3.6 V; Push-pull mode; all ports	V <sub>DD</sub> - 1.0	-	-	V
C <sub>iss</sub>	input capacitance		[4] -	-	15	pF
I <sub>IL</sub>	LOW-level input current	V <sub>I</sub> = 0.4 V	[5] -	-	-80	μA
I <sub>LI</sub>	input leakage current	V <sub>I</sub> = V <sub>IL</sub> , V <sub>IH</sub> , V <sub>th(HL)</sub>	[6] -	-	±10	μA
I <sub>T(HL)</sub>	HIGH to LOW transition current	V <sub>I</sub> = 1.5 V at V <sub>DD</sub> = 3.6 V	[7] -30	-	-450	μA

- [1] Typical ratings are not guaranteed. The values listed are at room temperature, V<sub>DD</sub> = 3 V.
- [2] The I<sub>DD(tpd)</sub> specification is measured using an external clock with the following functions disabled: comparators, real-time clock, brownout detect, and watchdog timer.
- [3] See [Section 8](#) for steady state (non-transient) limits on I<sub>OL</sub> or I<sub>OH</sub>. If I<sub>OL</sub>/I<sub>OH</sub> exceeds the test condition, V<sub>OL</sub>/V<sub>OH</sub> may exceed the related specification.
- [4] Pin capacitance is characterized but not tested.
- [5] Measured with port in Quasi-bidirectional mode.
- [6] Measured with port in High-impedance mode.
- [7] Port pins source a transition current when used in Quasi-bidirectional mode and externally driven from logic 1 to logic 0. This current is highest when V<sub>I</sub> is approximately 2 V.

**Table 10. AC electrical characteristics**

$V_{DD} = 2.4\text{ V to }3.6\text{ V unless otherwise specified.}$

$T_{amb} = -40\text{ }^{\circ}\text{C to }+85\text{ }^{\circ}\text{C for industrial applications, unless otherwise specified [1]}$

Symbol	Parameter	Conditions	Variable clock		Unit
			Min	Max	
f <sub>osc(int)</sub>	internal oscillator frequency		7.189	7.557	MHz
f <sub>osc(wd)</sub>	watchdog oscillator frequency		320	520	kHz

- [1] Parameters are valid over operating temperature range unless otherwise specified.

## 10. PMBus

### 10.1 Introduction

The PIP8000FHN supports the PMBus Power System Management Protocol Specifications, revision 1.1. In [Table 11](#) below all supported commands are marked grey. [Table 11](#) shows all supported commands including PIP8000FHN manufacturer specific commands.

The fan monitor counts the LOW to HIGH transitions from the fan tachometer. There are two fan inputs. The fan tachometer must produce a voltage swing with a LOW below 0.75 V and a HIGH above 2.5 V. The peak transition should be limited to 3.3 V to protect the PIP8000FHN measurement inputs.

### 10.2 Non-volatile memory

The PIP8000FHN has on board non-volatile memory to store:

- Configurable settings like  $V_{O(max)}$ , and  $V_O$ .
- Warning and fault thresholds for overvoltage, overcurrent, and overtemperature.
- Calibration information like coefficients.

During start-up the RESTORE\_USER\_ALL command is called to store all USER parameters into the running configuration. When settings are changed STORE\_USER\_ALL can be used to store the changed settings into the USER NVRAM storage area. RESTORE\_DEFAULT\_ALL and STORE\_DEFAULT\_ALL can be used to change parameters in the DEFAULT storage area. The running configuration needs to be used to swap between USER and DEFAULT storage area.

### 10.3 PMBus commands

[Table 11](#) contains a list of the PMBus commands.

Hex = PMBus command hex value, Command Name = PMBus command name, # = Number of Data Bytes. R/W/C = Read / Write / Command. Some commands are R/W where they are only defined as Read in the PMBus. The Write is supported to enable factory programming.

**Table 11. PMBus commands**

Hex	Command name	#	SMBus transaction type	Default value	Supported range	Comments
<b>ON, OFF, and margin testing</b>						
00	PAGE	1	R/W			
01	OPERATION <sup>[1]</sup>	1	R/W	0x80		
02	ON_OFF CONFIG <sup>[1]</sup>	1	R/W	0x18		
03	CLEAR_FAULTS <sup>[1]</sup>	0	C			
04	PHASE					
05	Reserved					
06	Reserved					

Table 11. PMBus commands ...continued

Hex	Command name	#	SMBus transaction type	Default value	Supported range	Comments
07	Reserved					
08	Reserved					
09	Reserved					
0A	Reserved					
0B	Reserved					
0C	Reserved					
0D	Reserved					
0E	Reserved					
0F	Reserved					
<b>Address and memory related commands</b>						
10	WRITE_PROTECT <sup>[1]</sup>	1	R/W	0x00		
11	STORE_DEFAULT_ALL <sup>[1]</sup>	0	C			
12	RESTORE_DEFAULT_ALL <sup>[1]</sup>	0	C			
13	STORE_DEFAULT_CODE	1	W			
14	RESTORE_DEFAULT_CODE	1	W			
15	STORE_USER_ALL <sup>[1]</sup>	0	C			
16	RESTORE_USER_ALL <sup>[1]</sup>	0	C			
17	STORE_USER_CODE	1	W			
18	RESTORE_USER_CODE	1	W			
19	CAPABILITY <sup>[1]</sup>	1	R			
1A	QUERY <sup>[1]</sup>	1	R			
1B	Reserved					
1C	Reserved					
1D	Reserved					
1E	Reserved					
1F	Reserved					
<b>Output voltage related commands</b>						
20	VOUT_MODE <sup>[1]</sup>	1	R/W	0x40		
21	VOUT_COMMAND <sup>[1]</sup>	2	R/W	0xD101		
22	VOUT_TRIM	2	R/W			
23	VOUT_CAL	2	R/W			
24	VOUT_MAX <sup>[1]</sup>	2	R/W	0x7303		
25	VOUT_MARGIN_HIGH <sup>[1]</sup>	2	R/W	0x4502		
26	VOUT_MARGIN_LOW <sup>[1]</sup>	2	R/W	0x1701		
27	VOUT_TRANSITION_RATE	2	R/W			
28	VOUT_DROOP					
29	VOLTAGE_SCALE_LOOP	2	R/W			
2A	VOLTAGE_SCALE_MONITOR	2	R/W			
2B	Reserved					

Table 11. PMBus commands ...continued

Hex	Command name	#	SMBus transaction type	Default value	Supported range	Comments
2C	Reserved					
2D	Reserved					
2E	Reserved					
2F	Reserved					
<b>Other commands</b>						
30	COEFFICIENTS <sup>[1]</sup>	5	R/W			
31	POUT_MAX	2	R/W			
32	MAX_DUTY	2	R/W			
33	FREQUENCY_SWITCH	2	R/W			
34	Reserved					
35	VIN_ON <sup>[1]</sup>	2	R/W	0x6E02		
36	VIN_OFF <sup>[1]</sup>	2	R/W	0x6803		
37	INTERLEAVE					
38	IOUT_CAL_GAIN	2	R/W			
39	IOUT_CAL_OFFSET	2	R/W			
3A	FAN_CONFIG_1_2 <sup>[1]</sup>	1	R/W	0xFF		
3B	FAN_COMMAND_1 <sup>[1]</sup>	2	R/W	0xFFFF		x x x x x 1 0 fan1 is off by setting P0.6 LOW x x x x x 1 1 fan1 is on by setting P0.6 HIGH x x x x x 0 0 fan1 is off by setting P0.6 HIGH x x x x x 0 1 fan1 is on by setting P0.6 LOW
3C	FAN_COMMAND_2 <sup>[1]</sup>	2	R/W	0xFFFF		x x x x x 1 0 fan1 is off by setting P0.7 LOW x x x x x 1 1 fan1 is on by setting P0.7 HIGH x x x x x 0 0 fan1 is off by setting P0.7 HIGH x x x x x 0 1 fan1 is on by setting P0.7 LOW
3D	FAN_CONFIG_3_4	1	R/W			
3E	FAN_COMMAND_3	2	R/W			
3F	FAN_COMMAND_4	2	R/W			
<b>Fault related commands</b>						
40	VOUT_OV_FAULT_LIMIT <sup>[1]</sup>	2	R/W	0x2703		
41	VOUT_OV_FAULT_RESPONSE <sup>[1]</sup>	1	R/W	0xBA		
42	VOUT_OV_WARN_LIMIT <sup>[1]</sup>	2	R/W	0x8002		
43	VOUT_UV_WARN_LIMIT <sup>[1]</sup>	2	R/W	0x3201		
44	VOUT_UV_FAULT_LIMIT <sup>[1]</sup>	2	R/W	0x8B00		
45	VOUT_UV_FAULT_RESPONSE <sup>[1]</sup>	1	R/W	0x00		
46	IOUT_OC_FAULT_LIMIT <sup>[1]</sup>	2	R/W	0x1805		

Table 11. PMBus commands ...continued

Hex	Command name	#	SMBus transaction type	Default value	Supported range	Comments
47	IOUT_OC_FAULT_RESPONSE <sup>[1]</sup>	1	R/W	0x00		
48	IOUT_OC_LV_FAULT_LIMIT	2	R/W			
49	IOUT_OC_LV_FAULT_RESPONSE	1	R/W			
4A	IOUT_OC_WARN_LIMIT <sup>[1]</sup>	2	R/W	0x9504		
4B	IOUT_UC_FAULT_LIMIT	2	R/W			
4C	IOUT_UC_FAULT_RESPONSE	1	R/W			
4D	Reserved					
4E	Reserved					
4F	OT_FAULT_LIMIT <sup>[1]</sup>	2	R/W	0x0002		
50	OT_FAULT_RESPONSE <sup>[1]</sup>	1	R/W	0x00		
51	OT_WARN_LIMIT <sup>[1]</sup>	2	R/W	0x0002		
52	UT_WARN_LIMIT	2	R/W			
53	UT_FAULT_LIMIT	2	R/W			
54	UT_FAULT_RESPONSE	1	R/W			
55	VIN_OV_FAULT_LIMIT <sup>[1]</sup>	2	R/W	0x6803		
56	VIN_OV_FAULT_RESPONSE <sup>[1]</sup>	1	R/W	0x00		
57	VIN_OV_WARN_LIMIT <sup>[1]</sup>	2	R/W	0x2903		
58	VIN_UV_WARN_LIMIT <sup>[1]</sup>	2	R/W	0x02AC		
59	VIN_UV_FAULT_LIMIT <sup>[1]</sup>	2	R/W	0x6E02		
5A	VIN_UV_FAULT_RESPONSE <sup>[1]</sup>	1	R/W	0x00		
5B	IIN_OC_FAULT_LIMIT <sup>[1]</sup>	2	R/W	0x8E02		
5C	IIN_OC_FAULT_RESPONSE <sup>[1]</sup>	1	R/W	0x00		
5D	IIN_OC_WARN_LIMIT <sup>[1]</sup>	2	R/W	0xEB01		
5E	POWER_GOOD_ON	2	R/W			
5F	POWER_GOOD_OFF	2	R/W			
<b>Output voltage sequencing commands</b>						
60	TON_DELAY <sup>[1]</sup>	2	R/W	0x0005		
61	TON_RISE <sup>[1]</sup>	2	R/W	0x0000		
62	TON_MAX_FAULT_LIMIT <sup>[1]</sup>	2	R/W	0x6400		
63	TON_MAX_FAULT_RESPONSE <sup>[1]</sup>	1	R/W	0x00		
64	TOFF_DELAY <sup>[1]</sup>	2	R/W	0x0000		
65	TOFF_FALL <sup>[1]</sup>	2	R/W	0x0000		
66	TOFF_MAX_WARN_LIMIT	2	R/W			
67	Reserved					
68	POUT_OP_FAULT_LIMIT	2	R/W			
69	POUT_OP_FAULT_RESPONSE	1	R/W			
6A	POUT_OP_WARN_LIMIT	2	R/W			
6B	PIN_OP_WARN_LIMIT	2	R/W			
6C	Reserved					

Table 11. PMBus commands ...continued

Hex	Command name	#	SMBus transaction type	Default value	Supported range	Comments
6D	Reserved					
6E	Reserved					
6F	Reserved					
<b>Unit status commands</b>						
70	Reserved					
71	Reserved					
72	Reserved					
73	Reserved					
74	Reserved					
75	Reserved					
76	Reserved					
77	Reserved					
78	STATUS_BYTE <sup>[1]</sup>	1	R	0x00		
79	STATUS_WORD <sup>[1]</sup>	2	R	0x0000		
7A	STATUS_VOUT <sup>[1]</sup>	1	R	0x00		
7B	STATUS_IOUT <sup>[1]</sup>	1	R	0x00		
7C	STATUS_INPUT <sup>[1]</sup>	1	R	0x00		
7D	STATUS_TEMPERATURE <sup>[1]</sup>	1	R	0x00		
7E	STATUS_CML <sup>[1]</sup>	1	R	0x00		
7F	STATUS_OTHER <sup>[1]</sup>	1	R	0x00		
80	STATUS_MFR_SPECIFIC <sup>[1]</sup>	1	R	0x00		
81	STATUS_FANS_1_2 <sup>[1]</sup>	1	R	0x00		
82	STATUS_FANS_3_4	1	R			
83	Reserved					
84	Reserved					
85	Reserved					
86	Reserved					
87	Reserved					
<b>Reading parametric information</b>						
88	READ_VIN <sup>[1]</sup>	2	R			
89	READ_IIN <sup>[1]</sup>	2	R			
8A	READ_VCAP					
8B	READ_VOUT <sup>[1]</sup>	2	R			
8C	READ_IOUT <sup>[1]</sup>	2	R			
8D	READ_TEMPERATURE_1 <sup>[1]</sup>	2	R			
8E	READ_TEMPERATURE_2 <sup>[1]</sup>	2	R			
8F	READ_TEMPERATURE_3					
90	READ_FANSPEED_1 <sup>[1]</sup>	2	R			
91	READ_FANSPEED_2 <sup>[1]</sup>	2	R			

Table 11. PMBus commands ...continued

Hex	Command name	#	SMBus transaction type	Default value	Supported range	Comments
92	READ_FANSPEED_3	2	R			
93	READ_FANSPEED_4	2	R			
94	READ_DUTY_CYCLE	2	R			
95	READ_FREQUENCY	2	R			
96	READ_POUT	2	R			
97	READ_PIN	2	R			
<b>Manufacturers information</b>						
98	PMBUS REVISION <sup>[1]</sup>	1	R			
<b>Inventory information</b>						
99	MFR_ID <sup>[1]</sup>	2	R/W	0x0100		
9A	MFR_MODEL <sup>[1]</sup>	2	R/W	0x0300		
9B	MFR_REVISION <sup>[1]</sup>	2	R/W	0x01BA		
9C	MFR_LOCATION <sup>[1]</sup>	2	R/W	0x565F		
9D	MFR_DATE <sup>[1]</sup>	4	R/W	0xFF00		
9E	MFR_SERIAL <sup>[1]</sup>	2	R/W	0xFFFF		
9F	Reserved					
<b>Manufacturer ratings</b>						
A0	MFR_VIN_MIN <sup>[1]</sup>	2	R/W	0x02FF		
A1	MFR_VIN_MAX <sup>[1]</sup>	2	R/W	0xFF05		
A2	MFR_IIN_MAX <sup>[1]</sup>	2	R/W	0x44FF		
A3	MFR_PIN_MAX <sup>[1]</sup>	2	R/W	0xFFFF		
A4	MFR_VOUT_MIN <sup>[1]</sup>	2	R/W	0x3000		
A5	MFR_VOUT_MAX <sup>[1]</sup>	2	R/W	0x0066		
A6	MFR_IOUT_MAX <sup>[1]</sup>	2	R/W	0xFFFF		
A7	MFR_POUT_MAX <sup>[1]</sup>	2	R/W	0xFFFF		
A8	MFR_TAMBIENT_MAX <sup>[1]</sup>	2	R/W	0xFFFF		
A9	MFR_TAMBIENT_MIN <sup>[1]</sup>	2	R/W	0x10FF		
AA	MFR_EFFICIENCY_LL					
AB	MFR_EFFICIENCY_HL					
AC	Reserved					
AD	Reserved					
AE	Reserved					
AF	Reserved					
<b>User data and configuration</b>						
B0	USER_DATA_00 <sup>[1]</sup>	2	R/W			
B1	USER_DATA_01					
B2	USER_DATA_02					
B3	USER_DATA_03					
B4	USER_DATA_04					

Table 11. PMBus commands ...continued

Hex	Command name	#	SMBus transaction type	Default value	Supported range	Comments
B5	USER_DATA_05					
B6	USER_DATA_06					
B7	USER_DATA_07					
B8	USER_DATA_08					
B9	USER_DATA_09					
BA	USER_DATA_10					
BB	USER_DATA_11					
BC	USER_DATA_12					
BD	USER_DATA_13					
BE	USER_DATA_14					
BF	USER_DATA_15					
C0	Reserved					
C1	Reserved					
C2	Reserved					
C3	Reserved					
C4	Reserved					
C5	Reserved					
C6	Reserved					
C7	Reserved					
C8	Reserved					
C9	Reserved					
CA	Reserved					
CB	Reserved					
CC	Reserved					
CD	Reserved					
CE	Reserved					
CF	Reserved					
<b>Manufacturer specific commands</b>						
D0	FAN_1_UNDERSPEED WARN_LIMIT <sup>[1]</sup>	2	R/W			
D1	FAN_1_UNDERSPEED FAULT_LIMIT <sup>[1]</sup>	2	R/W			
D2	FAN_2_UNDERSPEED WARN_LIMIT <sup>[1]</sup>	2	R/W			
D3	FAN_2_UNDERSPEED FAULT_LIMIT <sup>[1]</sup>	2	R/W			
D4	MFR_SPECIFIC_4					
D5	MFR_SPECIFIC_5					

Table 11. PMBus commands ...continued

Hex	Command name	#	SMBus transaction type	Default value	Supported range	Comments
D6	RETRY_TIME_MS <sup>[1]</sup>	1	R/W	0x0A		This is the fault response retry $V_O$ high time. It is used in Fault response mode to enable the $V_O$ to check if an error condition is resolved. RETRY_TIME_MS is specified in units of 10 ms. Default value is 0x0A, corresponding to a 100 ms delay.
D7	READ_USER_AD <sup>[1]</sup>	2	R			The PIP8000FHN has a user defined analog / digital converter. The value of the AD can be read with this command.
D8	TIME_UP <sup>[1]</sup>	4	R	0x00 0x00 0x00	Seconds 0-60 Minutes 0-60 Hours 0-43800	Total power uptime of the device. Byte 1 = Seconds, Byte 2 = Minutes, Byte 3 and 4 = Hours
D9	TIME_RESET <sup>[1]</sup>	0	C			Resets TIME_UP to zero
DA	CONFIG_COMMAND <sup>[1]</sup>	1		0x00	0x00 to 0x03	bit[0] = 1; GPIO output HIGH bit[1] = 1; Linear mode bit[7] = 1 PMBus state machine off. PMBUS_READ commands can be used to determine correct configuration parameters before enabling the PMBus state machine.
DB	MFR_SPECIFIC_11					
DC	MFR_SPECIFIC_12					
DD	ALERT_CONFIG <sup>[1]</sup>	1	R/W	0x00	0x00 - 0xFF	The byte specifies for which fault condition the SMBus SMAAlert protocol will be initiated.
DE	I2C_ADDRESS <sup>[1]</sup>	1	R/W	0x26	0x01 - 0xFF	The byte specifies the I <sup>2</sup> C address. If Bit[0] is the general call bit. When set, the general call address (00H) is recognized. Otherwise it is ignored.
DF	VERSION <sup>[1]</sup>	2	R	0x1222		PIP version number x.x.x.x. a nibble for each position
E0	RESET <sup>[1]</sup>					Software reset
E1	MFR_SPECIFIC_17					
E2	MFR_SPECIFIC_18					
E3	MFR_SPECIFIC_19					
E4	MFR_SPECIFIC_20					
E5	MFR_SPECIFIC_21					
E6	MFR_SPECIFIC_22					

Table 11. PMBus commands ...continued

Hex	Command name	#	SMBus transaction type	Default value	Supported range	Comments
E7	MFR_SPECIFIC_23					
E8	MFR_SPECIFIC_24					
E9	MFR_SPECIFIC_25					
EA	MFR_SPECIFIC_26					
EB	MFR_SPECIFIC_27					
EC	MFR_SPECIFIC_28					
ED	MFR_SPECIFIC_29					
EE	MFR_SPECIFIC_30					
EF	MFR_SPECIFIC_31					
F0	MFR_SPECIFIC_32					
F1	MFR_SPECIFIC_33					
F2	MFR_SPECIFIC_34					
F3	MFR_SPECIFIC_35					
F4	MFR_SPECIFIC_36					
F5	MFR_SPECIFIC_37					
F6	MFR_SPECIFIC_38					
F7	MFR_SPECIFIC_39					
F8	MFR_SPECIFIC_40					
F9	MFR_SPECIFIC_41					
FA	MFR_SPECIFIC_42					
FB	MFR_SPECIFIC_43					
FC	MFR_SPECIFIC_44					
FD	MFR_SPECIFIC_45					
FE	MFR_SPECIFIC_COMMAND_EXT					
FF	PMBUS_COMMAND_EXT					

[1] Supported command



## 12. Package outline

HVQFN28: plastic thermal enhanced very thin quad flat package; no leads; 28 terminals; body 6 x 6 x 0.85 mm

SOT788-1

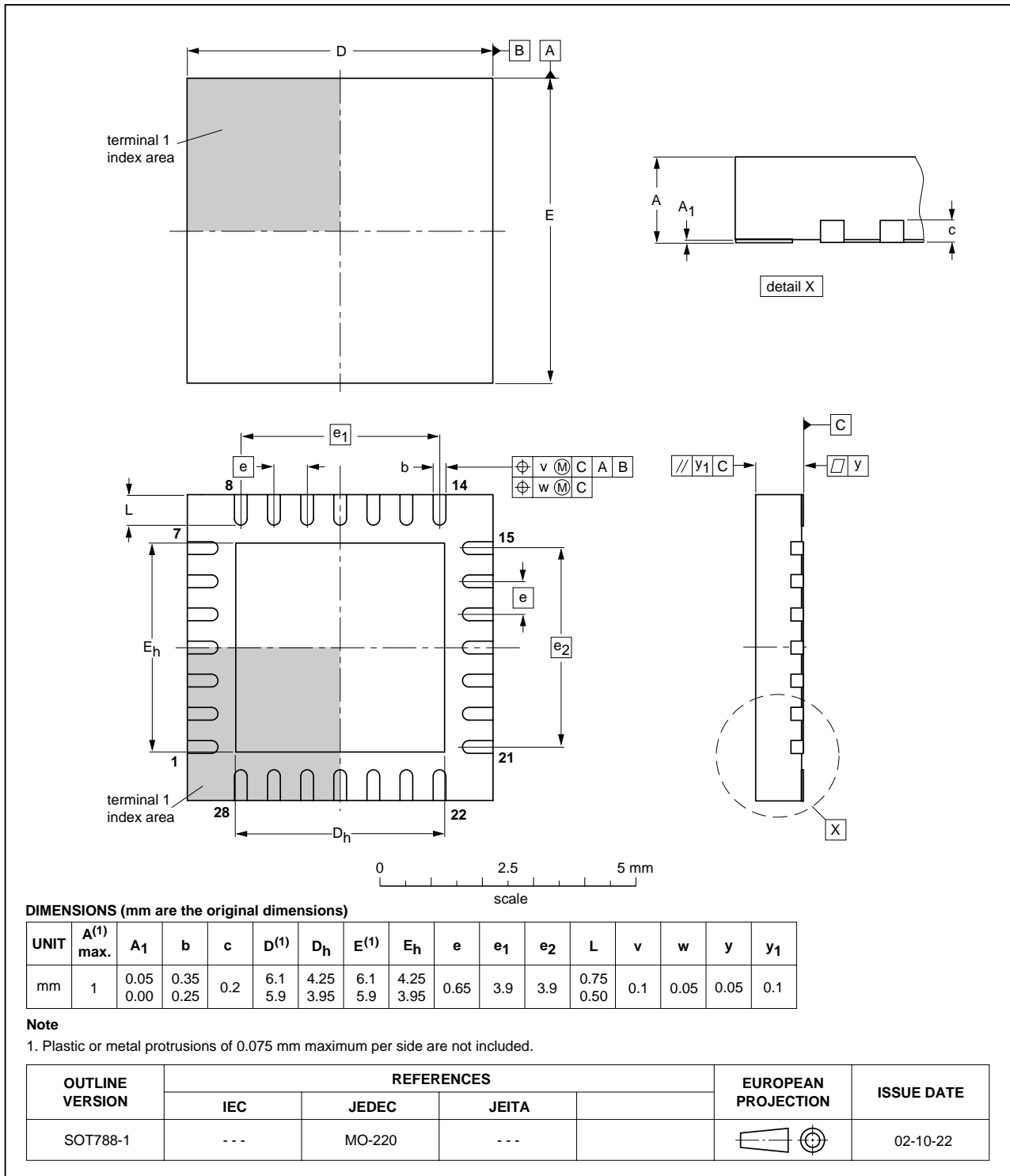

Fig 5. Package outline SOT788-1 (HVQFN28)

## 13. Revision history

Table 12. Revision history

Document ID	Release date	Data sheet status	Change notice	Supersedes
PIP8000FHN_2	20090706	Preliminary data sheet	-	PIP8000FHN_1
Modifications				
<ul style="list-style-type: none"><li>• <a href="#">Figure 2 "Pin configuration"</a> package outline updated.</li></ul>				
PIP8000FHN_1	20090312	Preliminary data sheet	-	-

## 14. Legal information

### 14.1 Data sheet status

Document status <sup>[1][2]</sup>	Product status <sup>[3]</sup>	Definition
Objective [short] data sheet	Development	This document contains data from the objective specification for product development.
Preliminary [short] data sheet	Qualification	This document contains data from the preliminary specification.
Product [short] data sheet	Production	This document contains the product specification.

[1] Please consult the most recently issued document before initiating or completing a design.

[2] The term 'short data sheet' is explained in section "Definitions".

[3] The product status of device(s) described in this document may have changed since this document was published and may differ in case of multiple devices. The latest product status information is available on the Internet at URL <http://www.nxp.com>.

### 14.2 Definitions

**Draft** — The document is a draft version only. The content is still under internal review and subject to formal approval, which may result in modifications or additions. NXP Semiconductors does not give any representations or warranties as to the accuracy or completeness of information included herein and shall have no liability for the consequences of use of such information.

**Short data sheet** — A short data sheet is an extract from a full data sheet with the same product type number(s) and title. A short data sheet is intended for quick reference only and should not be relied upon to contain detailed and full information. For detailed and full information see the relevant full data sheet, which is available on request via the local NXP Semiconductors sales office. In case of any inconsistency or conflict with the short data sheet, the full data sheet shall prevail.

### 14.3 Disclaimers

**General** — Information in this document is believed to be accurate and reliable. However, NXP Semiconductors does not give any representations or warranties, expressed or implied, as to the accuracy or completeness of such information and shall have no liability for the consequences of use of such information.

**Right to make changes** — NXP Semiconductors reserves the right to make changes to information published in this document, including without limitation specifications and product descriptions, at any time and without notice. This document supersedes and replaces all information supplied prior to the publication hereof.

**Suitability for use** — NXP Semiconductors products are not designed, authorized or warranted to be suitable for use in medical, military, aircraft, space or life support equipment, nor in applications where failure or malfunction of an NXP Semiconductors product can reasonably be expected to result in personal injury, death or severe property or environmental

damage. NXP Semiconductors accepts no liability for inclusion and/or use of NXP Semiconductors products in such equipment or applications and therefore such inclusion and/or use is at the customer's own risk.

**Applications** — Applications that are described herein for any of these products are for illustrative purposes only. NXP Semiconductors makes no representation or warranty that such applications will be suitable for the specified use without further testing or modification.

**Limiting values** — Stress above one or more limiting values (as defined in the Absolute Maximum Ratings System of IEC 60134) may cause permanent damage to the device. Limiting values are stress ratings only and operation of the device at these or any other conditions above those given in the Characteristics sections of this document is not implied. Exposure to limiting values for extended periods may affect device reliability.

**Terms and conditions of sale** — NXP Semiconductors products are sold subject to the general terms and conditions of commercial sale, as published at <http://www.nxp.com/profile/terms>, including those pertaining to warranty, intellectual property rights infringement and limitation of liability, unless explicitly otherwise agreed to in writing by NXP Semiconductors. In case of any inconsistency or conflict between information in this document and such terms and conditions, the latter will prevail.

**No offer to sell or license** — Nothing in this document may be interpreted or construed as an offer to sell products that is open for acceptance or the grant, conveyance or implication of any license under any copyrights, patents or other industrial or intellectual property rights.

**Export control** — This document as well as the item(s) described herein may be subject to export control regulations. Export might require a prior authorization from national authorities.

### 14.4 Trademarks

Notice: All referenced brands, product names, service names and trademarks are the property of their respective owners.

**I<sup>2</sup>C-bus** — logo is a trademark of NXP B.V.

## 15. Contact information

For more information, please visit: <http://www.nxp.com>

For sales office addresses, please send an email to: [salesaddresses@nxp.com](mailto:salesaddresses@nxp.com)

**16. Contents**

**1 General description . . . . . 1**

**2 Features . . . . . 1**

**3 Applications . . . . . 1**

**4 Ordering information . . . . . 2**

**5 Block diagram . . . . . 2**

**6 Pinning information . . . . . 3**

6.1 Pinning . . . . . 3

6.2 Pin description . . . . . 3

**7 Functional description . . . . . 5**

7.1 System interfaces . . . . . 5

7.2 Operations . . . . . 5

7.3 Product functions . . . . . 5

7.4 Host interface . . . . . 5

7.4.1 I<sup>2</sup>C slave address . . . . . 5

7.4.2 ALERT functionality . . . . . 6

7.4.3 Packet Error Check (PEC) . . . . . 7

7.4.4 Data formats . . . . . 7

7.4.5 Coefficients and query . . . . . 9

7.5 Power-up /power-down . . . . . 9

7.6 OPERATION and ON\_OFF\_CONFIG . . . . . 9

7.7 ALERT\_CONFIG . . . . . 10

**8 Limiting values . . . . . 11**

**9 Characteristics . . . . . 11**

**10 PMBus . . . . . 13**

10.1 Introduction . . . . . 13

10.2 Non-volatile memory . . . . . 13

10.3 PMBus commands . . . . . 13

**11 Application information . . . . . 22**

**12 Package outline . . . . . 23**

**13 Revision history . . . . . 24**

**14 Legal information . . . . . 25**

14.1 Data sheet status . . . . . 25

14.2 Definitions . . . . . 25

14.3 Disclaimers . . . . . 25

14.4 Trademarks . . . . . 25

**15 Contact information . . . . . 25**

**16 Contents . . . . . 26**

Please be aware that important notices concerning this document and the product(s) described herein, have been included in section 'Legal information'.



© NXP B.V. 2009.

All rights reserved.

For more information, please visit: <http://www.nxp.com>

For sales office addresses, please send an email to: [salesaddresses@nxp.com](mailto:salesaddresses@nxp.com)

Date of release: 6 July 2009

Document identifier: PIP8000FHN\_2