



NXP 3-W Class AB, BTL audio amplifier SA58631

Audio amplifier for portable applications

This single-channel audio amplifier provides a power output of 3 W with an 8- Ω load using a 9-V supply. Housed in an HVSON8 package with an exposed die-attach paddle, it delivers reduced thermal resistance and increased power dissipation.

Key features

- ▶ Low junction-to-ambient thermal resistance
- ▶ Fixable gain (6 to 30 dB)
- ▶ Low standby current (<10 μ A)
- ▶ Standby mode controlled by CMOS-compatible levels
- ▶ No switch-on/switch-off plops
- ▶ High PSRR (50 dB minimum)
- ▶ ESD protection
- ▶ Output short-circuit-to-ground protection
- ▶ Thermal-shutdown protection
- ▶ HVSON8 package (4 x 4 x 0.8 mm)

Applications

- ▶ Professional and amateur mobile radio
- ▶ Portable consumer products (toys, games, etc.)
- ▶ PC remote speakers
- ▶ PC sound cards

The NXP 3-W Class AB, BTL audio amplifier SA58631 increases dissipation capability, so it is an excellent choice for a broad range of portable applications, including mobile radios, 9- and 12-V speakers, toys, games, and PC sound cards. It also supports operating systems that run between 2 and 18 V.

The device is housed in an 8-pin HVSON that measures only 4 x 4 x 0.8 mm. The package has an exposed die-attach paddle, so it reduces junction-to-ambient thermal resistance and increases power dissipation.

With a supply voltage of 9 V and an 8- Ω loudspeaker, the SA58631 can deliver an output power of 3 W. In standby mode, it consumes less than 10 μ A.

The internal circuit is a BTL (Bridge Tied Load) amplifier with a complementary PNP-NPN output stage and on-chip logic for standby and mute. Total voltage loss is less than 1 V.

The device can be switched to standby and mute conditions via the MODE pin. Standby mode can be controlled by CMOS-compatible levels.

Using external feedback resistors, the gain can be fixed from 6 to 30 dB.

The device offers a minimum power-supply ripple-rejection (PSRR) ratio of 50 dB and has integrated circuitry that protects against ESD, output short-circuit to ground, and thermal shutdown.

For more information visit:
www.standardics.nxp.com

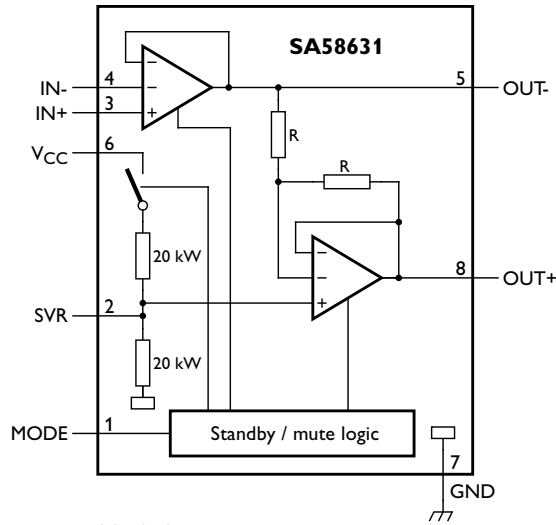

SA58631 block diagram

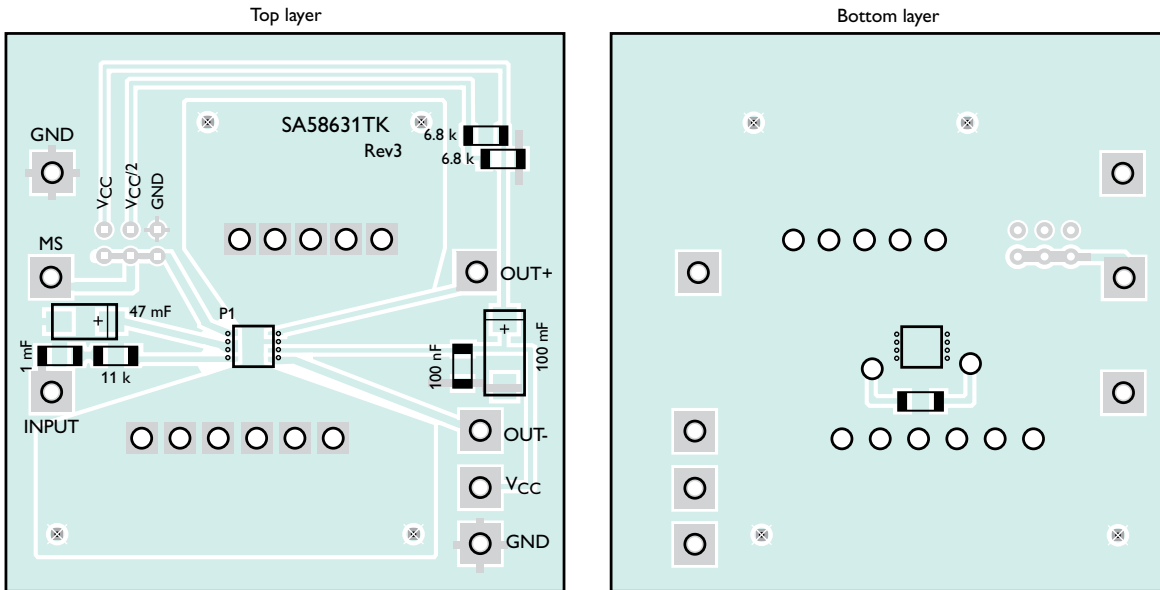

SA58631 demo board

Ordering information

Type number	Temperature range	Package	Dimensions	Version
SA58631TK	-40 to +85 °C	8-pin HVSON	4 x 4 x 0.8 mm	SOT909-1

www.nxp.com



NXP Semiconductors is in the process of being established as a separate legal entity in various countries worldwide. This process will be finalized in the course of 2006.

© 2006 Koninklijke Philips Electronics N.V.

All rights reserved. Reproduction in whole or in part is prohibited without the prior written consent of the copyright owner. The information presented in this document does not form part of any quotation or contract, is believed to be accurate and reliable and may be changed without notice. No liability will be accepted by the publisher for any consequence of its use. Publication thereof does not convey nor imply any license under patent or other industrial or intellectual property rights.

Date of release: September 2006

Document order number: 9397 750 15673

Printed in the USA