

1. Quick start

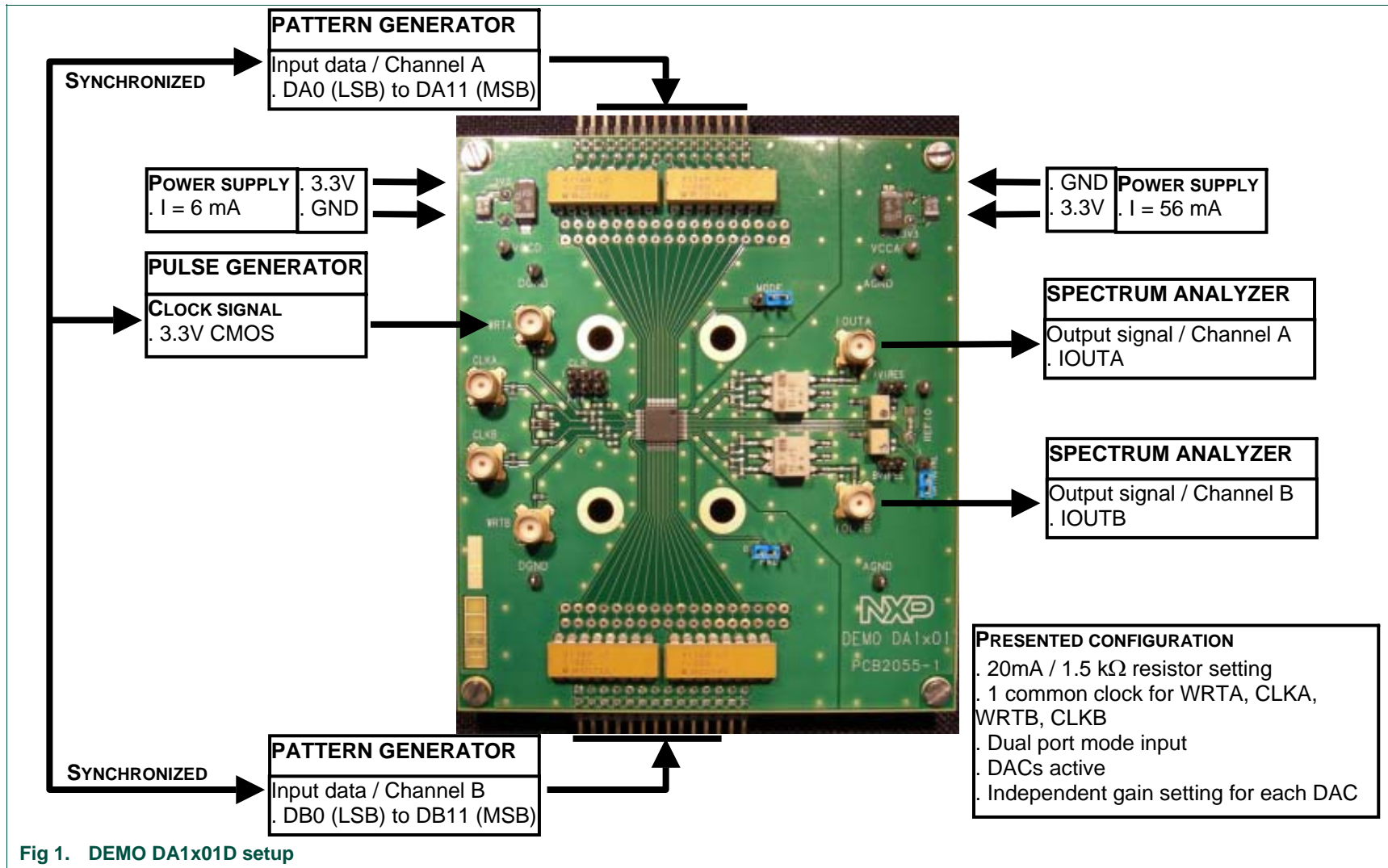

1.1 Setup overview

Figure Fig.1 presents the connections to measure DEMO DA1x01D.

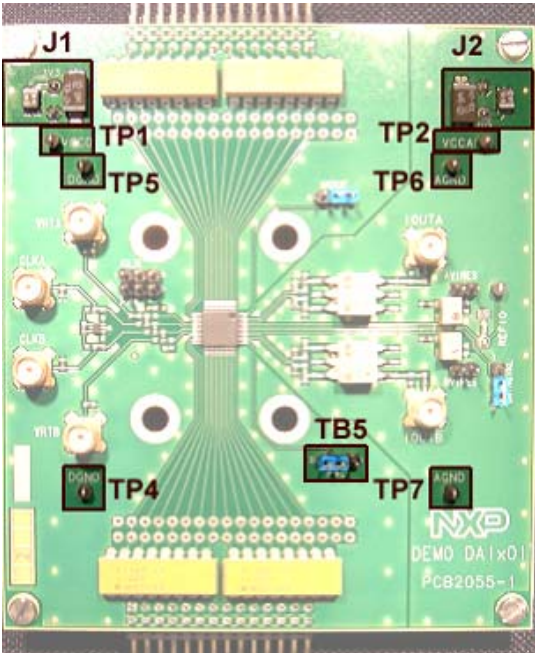

1.2 Power supply

Table 1. General power supply

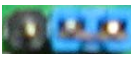
Name	Function	View
J1	VDDD connector – Digital power supply 3.3 V _{DC} / 6 mA.	
J2	VDDA connector – Analog power supply 3.3 V _{DC} / 56 mA	
TP1	VDDD test point – Digital power supply	
TP2	VDDA test point – Analog power supply	
TP4, TP5	DGND test point – Digital ground	
TP6, TP7	AGND test point – Analog ground	
TB5	PWD switch – Power down selection	
	 	
	DACs active	Power down

1.3 Output current and gain adjustments

Table 2. Output current and gain adjustments

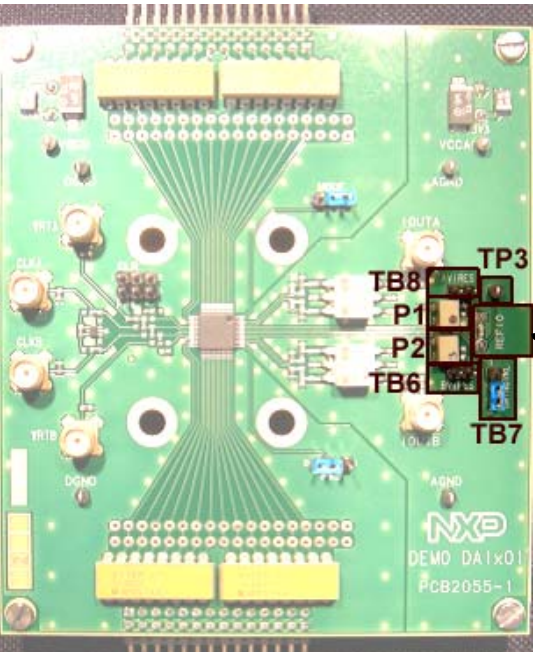
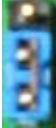
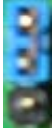
Name	Function	View	
P1	AVIRES trimmer – Channel A full-scale current setting		
TB8	AVIRES test point – Channel A resistor test point (1.5 k Ω for 20 mA)		
P2	BVIRES trimmer – Channel B full-scale current setting		
TB6	BVIRES test point – Channel B resistor test point (1.5 k Ω for 20 mA)		
TB7	GAINCTRL switch – Gain control selection		
	2 independent resistors for full-scale current setting of both channels 		1 common resistor (P1) for full-scale current setting of both channels 
J3	REFIO connector – External input for reference adjustment		
TP3	REFIO test point – Reference I/O (typ. 1.25 V)		

1.4 Input/output datas

Table 3. Input/output datas

Name	Function	View
TB1	Array connector – Channel A digital inputl (DA0 to DA11)	
J9	IOUTA connector – Channel A analog output signal (100 Ω differential resitor)	
TB2	Array connector – Channel B digital inputl (DB0 to DB11)	
J8	IOUTA connector – Channel B analog output signal (100 Ω differBntial resitor)	
TB9	MODE switch – Mode selection	

Interleaved data input	Dual-port data input

1.5 Clock signals

Table 4. Clock signals

Name	Function	View
J4	WRTA connector – Write A input	
J5	CLKA connector – Clock A input	
J6	WRTB connector – Write B input	
J7	CLKB connector – Clock B input	
net	Dual-port mode: 1 common clock (WRTA) for WRTA, CLKA, WRTB and CLKB	
	Dual-port mode: 4 clock inputs for WRTA, CLKA, WRTB and CLKB	
	Dual-port mode: 1 common clock (CLKA) with 2 buffers for WRTA, CLKA, WRTB and CLKB	

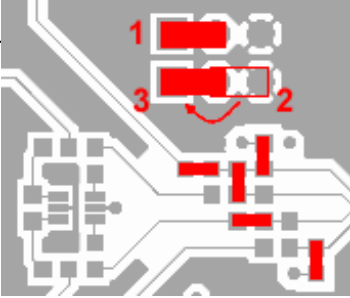
Name	Function	View
	<p data-bbox="236 203 432 230">Interleaved mode:</p> <ul data-bbox="236 237 501 539" style="list-style-type: none"><li data-bbox="236 237 501 293">- WRTA input for IQWRT and IQCLK<li data-bbox="236 300 501 356">- CLKB input for IQRESET<li data-bbox="236 362 501 427">- IQSEL is generated by the 74LCX112M<ol data-bbox="268 434 437 539" style="list-style-type: none"><li data-bbox="268 434 437 461">1. Put CLR to 1<li data-bbox="268 468 437 495">2. Put PRE to 0<li data-bbox="268 501 437 528">3. Put PRE to 1	

2. Example

2.1 Setup example

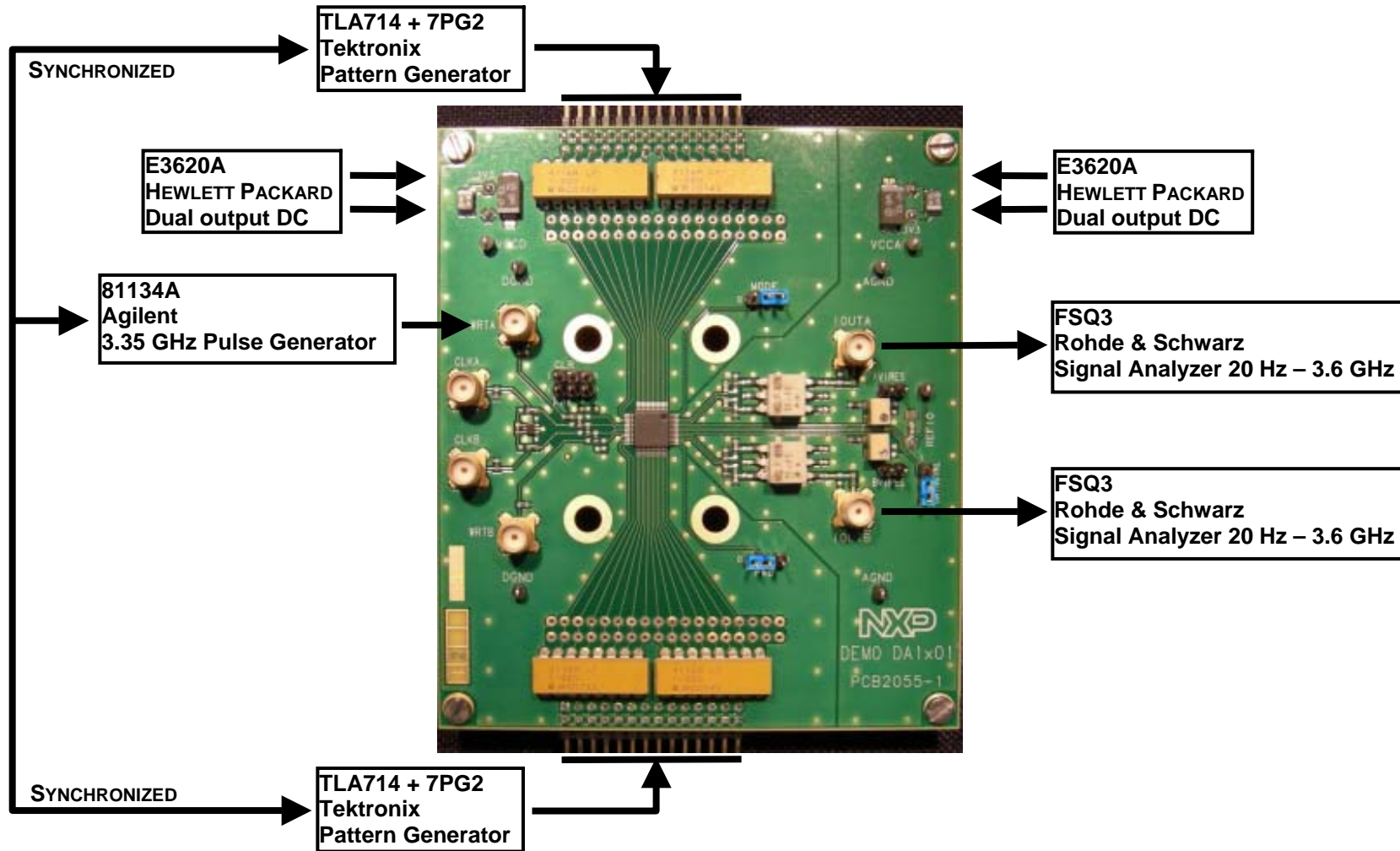

Fig 2. DAC1201D125 hardware setup