

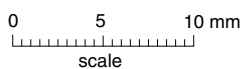

Plastic single-ended package (I2PAK); low-profile 3-lead TO-262

SOT226

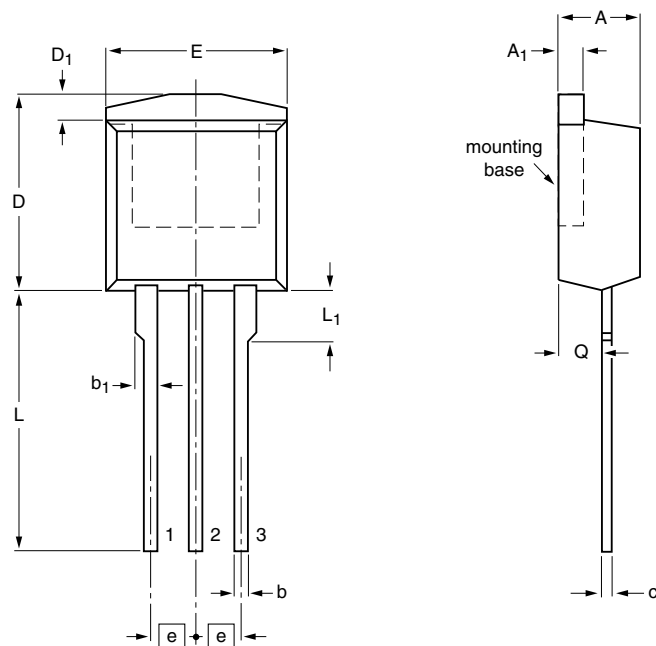

DIMENSIONS (mm are the original dimensions)

UNIT	A	A ₁	b	b ₁	c	D _{max}	D ₁	E	e	L	L ₁	Q
mm	4.5	1.40	0.85	1.3	0.7	11	1.6	10.3	2.54	15.0	3.30	2.6
	4.1	1.27	0.60	1.0	0.4		1.2	9.7		13.5	2.79	2.2

OUTLINE VERSION	REFERENCES				EUROPEAN PROJECTION	ISSUE DATE
	IEC	JEDEC	JEITA			
SOT226		TO-262				-06-02-14- 09-08-25