

**HTSSOP38: plastic thermal enhanced thin shrink small outline package;
38 leads; body width 6.1 mm; lead pitch 0.65 mm; exposed die pad**

SOT633-1

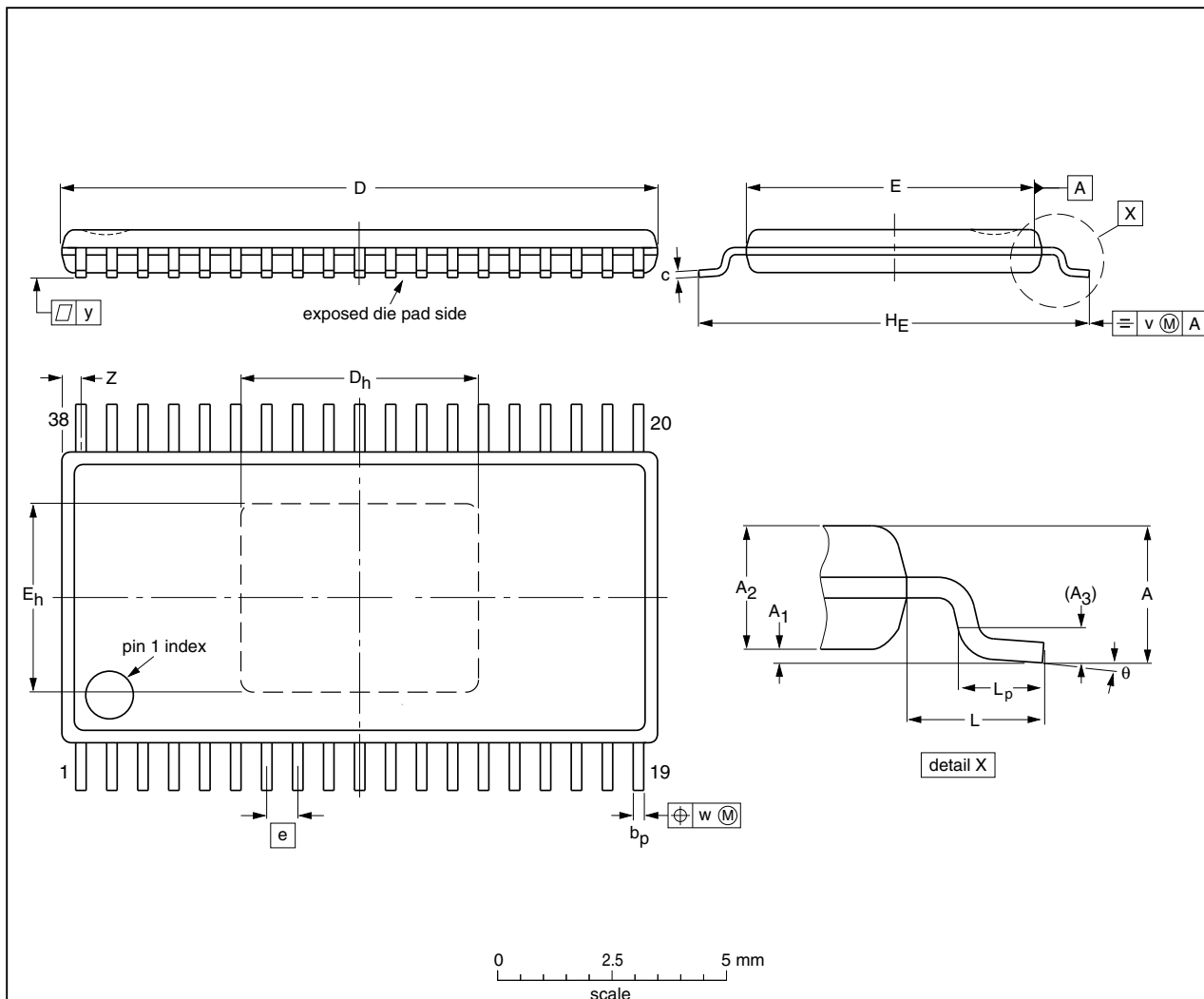

DIMENSIONS (mm are the original dimensions).

UNIT	A max.	A ₁	A ₂	A ₃	b _p	c	D ⁽¹⁾	D _h	E ⁽²⁾	E _h	e	H _E	L	L _p	v	w	y	Z	θ
mm	1.2	0.15 0.05	1.05 0.80	0.25	0.30 0.19	0.20 0.09	12.6 12.4	5.1 4.9	6.2 6.0	4.1 3.9	0.65	8.3 7.9	1	0.75 0.45	0.2	0.1	0.1	0.6 0.2	8° 0°

Notes

1. Plastic or metal protrusions of 0.15 mm maximum per side are not included.
2. Plastic interlead protrusions of 0.25 mm maximum per side are not included.

OUTLINE VERSION	REFERENCES			EUROPEAN PROJECTION	ISSUE DATE
	IEC	JEDEC	JEITA		
SOT633-1		MO-153			03-02-18- 03-04-07