

UM10155

Discrete Class D High Power Audio Amplifier

Rev. 02 — 5 September 2006

User manual

Document information

Info	Content
Keywords	Class D Audio Amplifier, Universal Class D, UcD, PWM Audio Amplifier, High Power Audio.
Abstract	This user manual describes the operating instructions and the most important background information of the Philips Semiconductor Discrete Class D High Power Audio Amplifier Demonstrator Board. With proper heatsinking of the Power MOSFETs and a well dimensioned power supply, the PWM amplifier is capable of supplying 200 W of high quality audio power into a 4 Ω loudspeaker.

The Philips logo, consisting of the word "PHILIPS" in a bold, blue, sans-serif font.

Revision history

Rev	Date	Description
02	20060905	corrected Figure 9 .
01	20060801	initial version

Contact information

For additional information, please visit: <http://www.semiconductors.philips.com>

For sales office addresses, please send an email to: sales.addresses@www.semiconductors.philips.com

1. Introduction

The Universal Class D (UcD) version 1.00 demonstrator board implements a 200 W true RMS (into a 4 Ω load) high quality audio power amplifier on a very compact printed-circuit board. The amplifier is built-up of discrete components only, and makes use of Philips patent WO 03/090343.

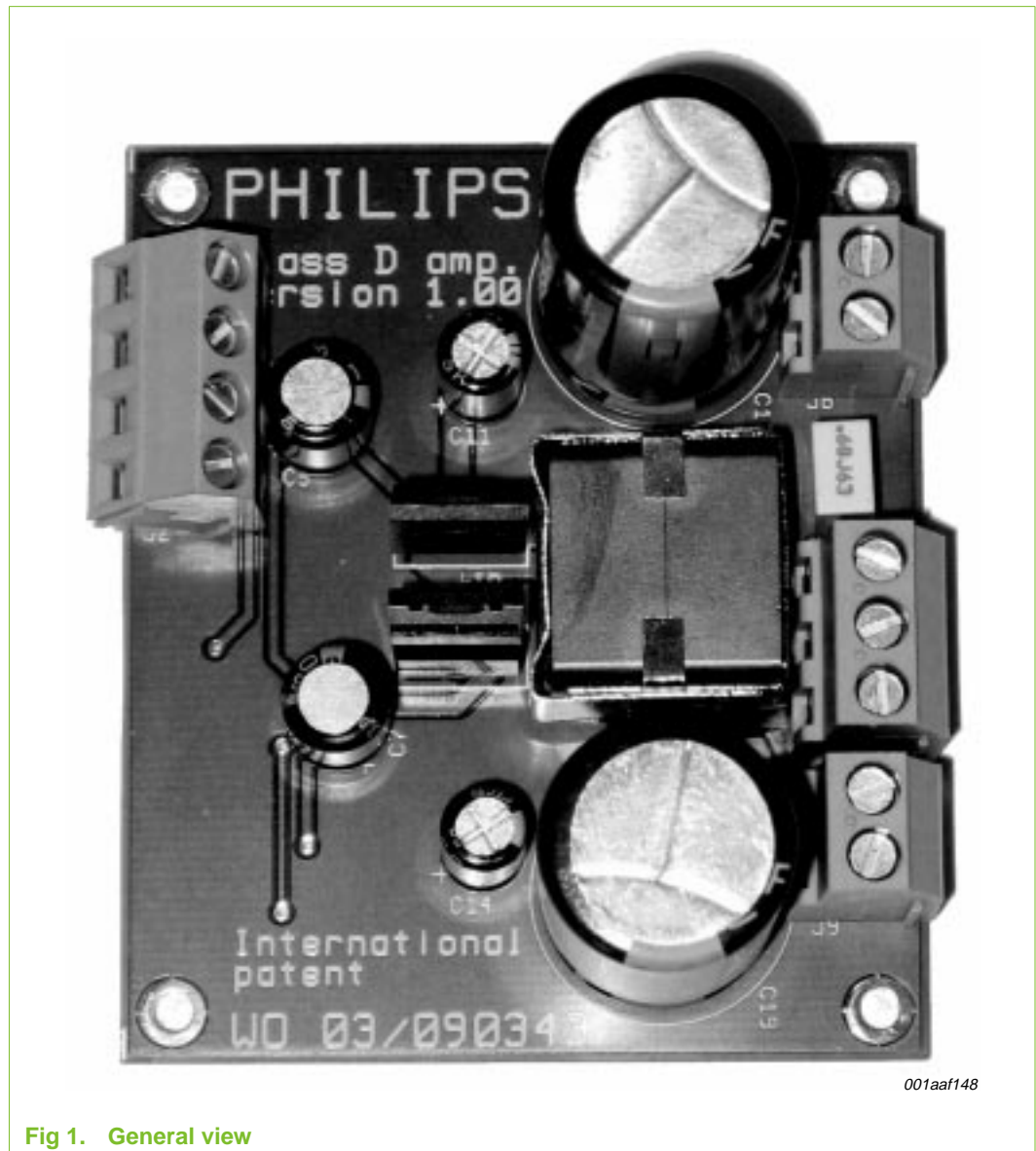

Fig 1. General view

The demonstrator board is intended to illustrate the capability of Philips Power MOSFETs in discrete high-end PWM audio amplifier applications. The board is self-contained and only requires a simple (non-stabilized) dual power supply, an audio source (e.g. function generator, CD player) and a loudspeaker to demonstrate its capabilities. For evaluation at high output power a provision is made to attach an appropriate heatsink to the MOSFETs on the board.

2. Circuit diagram

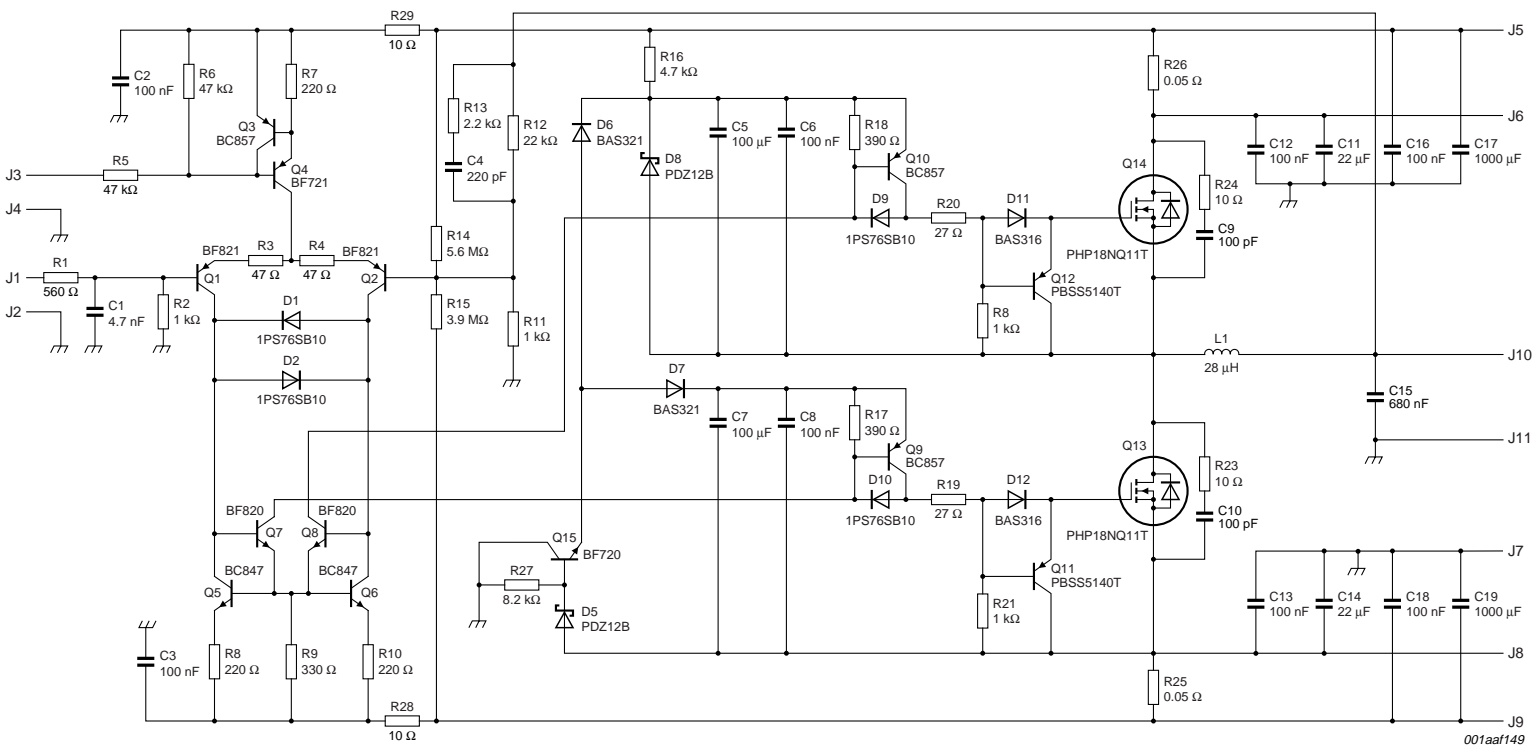

Fig 2. Circuit diagram

Table 1. Connections

Connector	Function	Remarks
J1	audio in - signal	use together with J2
J2	audio in - ground	use together with J1
J3	amplifier enable	when connected to ground (J4) the amplifier is enabled
J4	ground	use together with J3
J5	positive supply voltage	30 V to 45 V (no need for a stabilized power supply)
J6	positive current sense	can optionally be used in an overcurrent protection scheme
J7	power supply ground	0 V
J8	negative current sense	can optionally be used in an overcurrent protection scheme
J9	negative supply voltage	-30 V to -45 V (no need for a stabilized power supply)
J10	loudspeaker output	use together with J11
J11	loudspeaker ground	use together with J10

3. Printed-circuit board layout

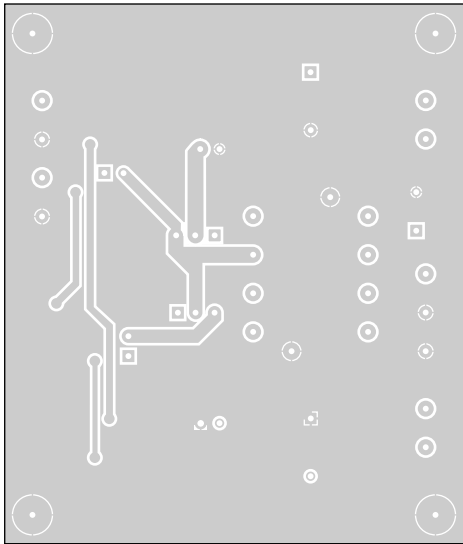

Fig 3. Top copper layout

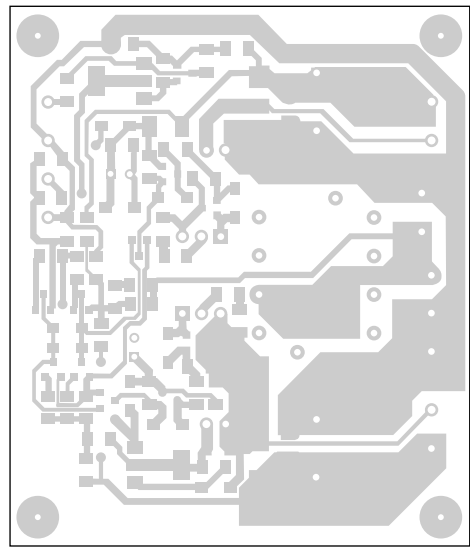
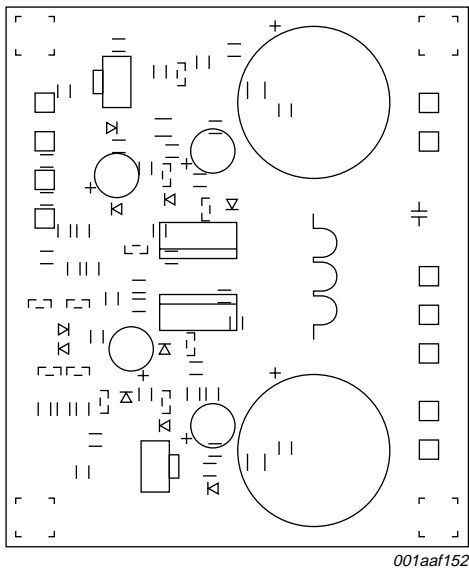
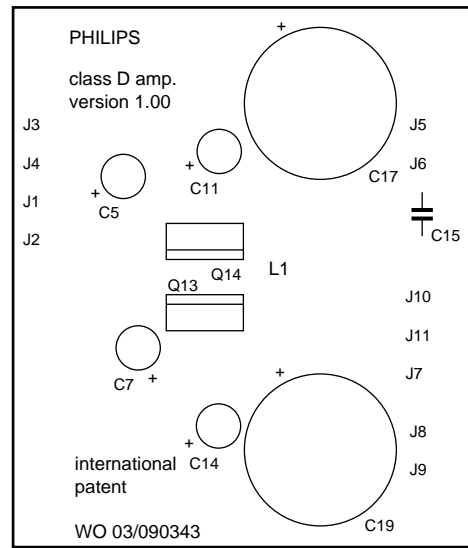

Fig 4. Bottom copper layout



001aaf152

Fig 5. Component layout



001aaf153

Fig 6. Top silk-screen

4. Specifications

Table 2. Specifications

Symbol	Parameter	Conditions	Value
V_P	supply voltage	equal positive and negative supply voltages	± 30 V to ± 45 V
P_L	output power	$V_P = \pm 45$ V; $R_L = 4 \Omega$; appropriate heatsink needed	200 W (RMS)
η	efficiency	$P_L = 100$ W; $R_L = 4 \Omega$	> 92 %
THD+N	total harmonic distortion-plus-noise	$P_L = 10$ W; frequency range from 20 Hz to 20 kHz	< 0.03 %
S/N	signal-to-noise ratio		> 120 dB
f_{PWM}	PWM frequency	idle	~ 400 kHz
V_{offset}	offset voltage	DC value	< 50 mV

4.1 Pop-less/click-less start-up and shutdown

A provision has been added to the circuit to provide pop-less/click-less start-up and shutdown. To make use of the start-up facility, make sure that the supply power (pins J5 and J9) is applied prior to enabling the amplifier (connecting J3 to J4). To benefit from the pop-less shutdown feature, disable the amplifier (disconnect J3 and J4) prior to removing the supply power.

4.2 Overcurrent protection

A provision has been added to the circuit to monitor the current flowing through the Power MOSFETs (Q13 and Q14). The voltage appearing between pins J5 and J6 is proportional to the current in MOSFET Q14 (ratio: 50 mV/A) and the voltage between J8 and J9 is proportional to the current in MOSFET Q13 (ratio: 50 mV/A). With the use of an external

circuit these two signals may be used to disable the amplifier (disconnect J3 and J4) in case of an overcurrent situation. Similarly the J3-J4 pin combination can be used to disable the amplifier in case of other fault conditions.

4.3 Important notice

The ‘High Power Class D Audio Amplifier Demonstrator Board’ is meant to demonstrate the capabilities of the specific Class D Amplifier design and its semiconductor components. No provisions for short-circuit and overcurrent protection were made on the demonstrator board itself. Neither was an operating temperature compensation feature implemented on the board. The circuit on the board is reduced to its essentials.

In this implementation the ‘High Power Class D Audio Amplifier Demonstrator Board’ is not intended to be used for long term operation or under extreme temperature conditions when delivering substantial output power.

5. Wiring diagram and powering-up

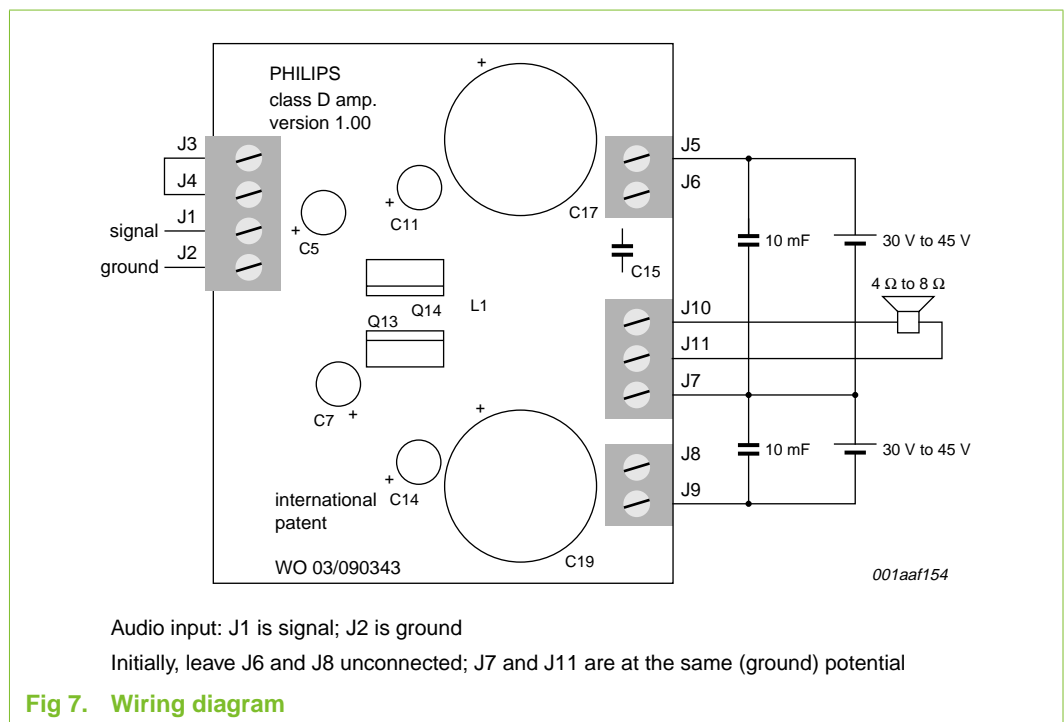

6. Adding external features

6.1 Electronic enabling/disabling of the amplifier

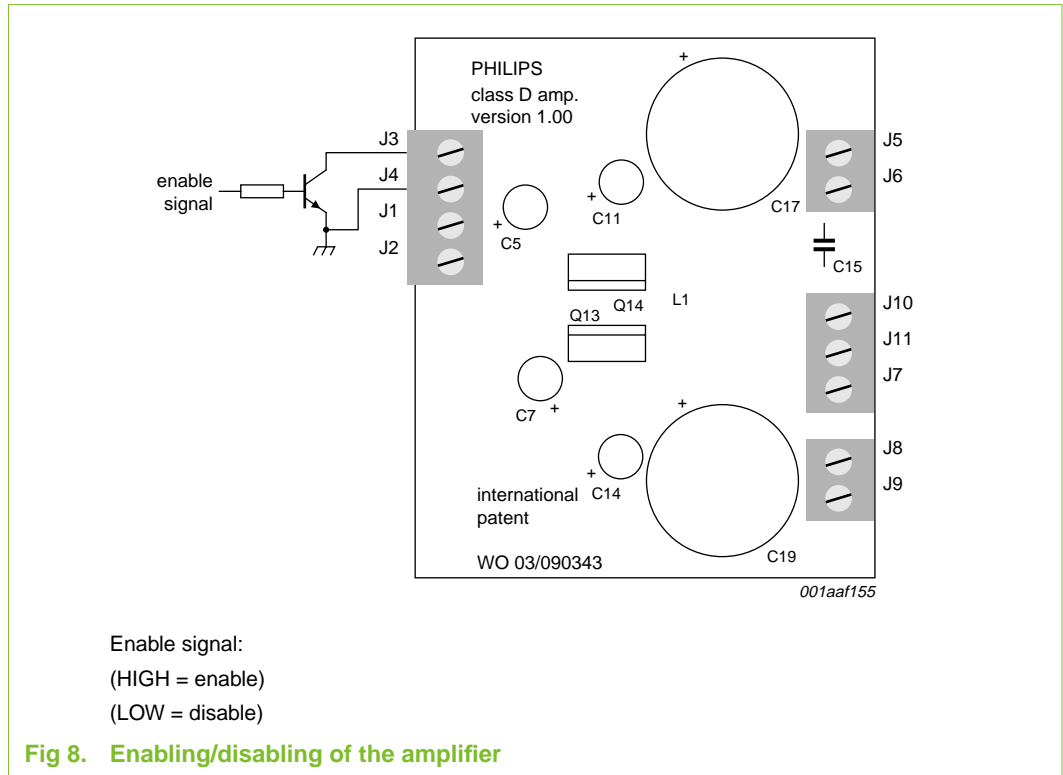

Electronic enabling/disabling can be used for:

- Implementing pop-less and click-less start-up and shut-down
- Shutting down the amplifier in case of a failure condition (short-circuit/overcurrent/over-temperature)

The transistor in the enabling/disabling circuit must be low current, 60 V type (such as BC846) and the resistor must limit the base current of the transistor to approximately 1 mA (in case of logic level driving, that would mean $R = 4.7 \text{ k}\Omega$).

6.2 Short-circuit and overcurrent protection

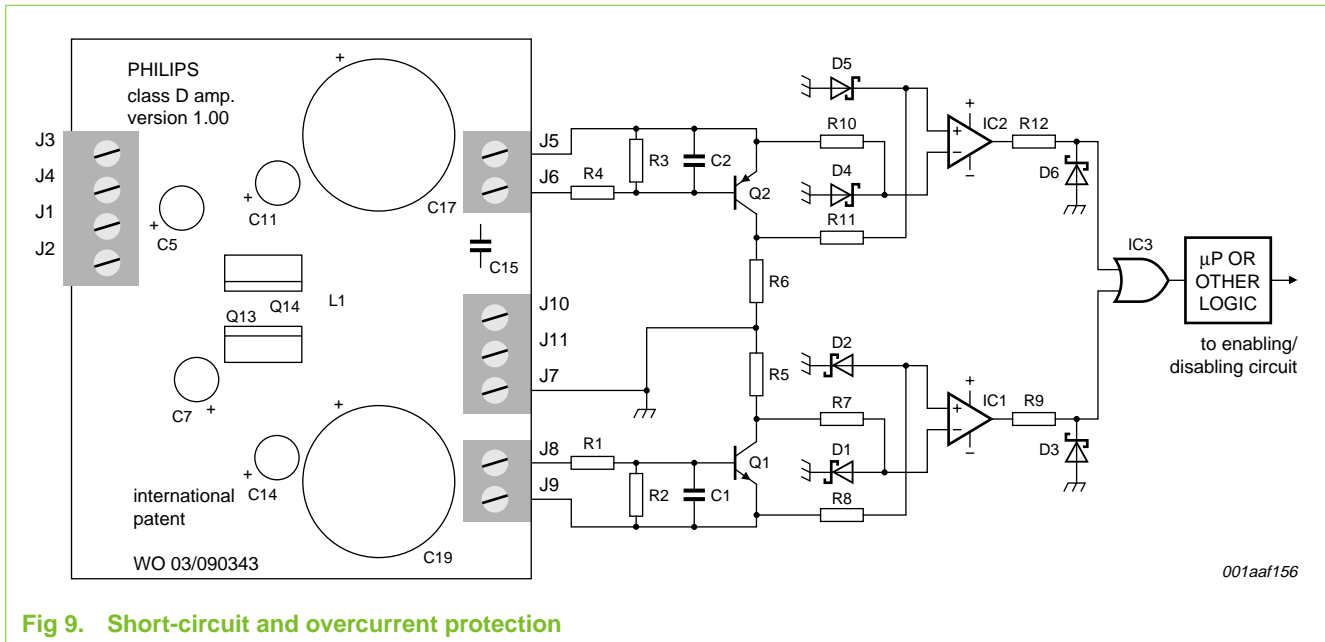

Fig 9. Short-circuit and overcurrent protection

The ‘Short-circuit and overcurrent protection’ circuit must be used together with the ‘Electronic enabling/disabling’ circuit.

The output pins of IC1 and IC2 produce a HIGH logic level pulse when overcurrent is detected in either the low side MOSFET (Q13 on the Demonstrator Board) and high side MOSFET (Q14 on the Demonstrator Board) respectively. The two signals are combined through the IC3 OR-gate. The resulting signal must be processed in the ‘μP or other logic’ block. One of the simplest solutions would be a latch circuit, which on a high pulse forces the output go low. This causes the ‘Electronic enabling/disabling circuit’ to disable the amplifier. Through manual intervention and/or after a certain while, the latch should be reset to a HIGH logic level, which in turn re-enables the amplifier.

Table 3. Components

Component	Value
R1, R4	270 Ω
R2, R3	4.7 kΩ
R5, R6, R7, R8, R9, R10, R11, R12	10 kΩ
C1, C2	4.7 nF
D1, D5	Philips PDZ10B
D2, D3, D4, D6	Philips PDZ5.1B
Q1	Philips BC846
Q2	Philips BC856
IC1, IC2	Fast operational amplifier; feed with +12 V and -12 V supplies
IC3	Philips HEF4071; feed with 5 V

6.3 Sonic performance versus Efficiency trade-off

The dead-time that is allowed between Q13 and Q14 conduction determines the efficiency of the Demonstrator Board for a great deal; a long dead-time leads to better efficiency. On the other side, long dead-time also leads to worse sonic performance; it has important adverse consequences for e.g. THD.

Short dead-time causes quiescent current to go up, thus reducing efficiency and improving sonic performance. The higher quiescent current is the result of more cross-conduction of Q13 and Q14. So, most of the power that is lost in this way is dissipated in Q13 and Q14, which may heat-up excessively. This may cause thermally instable behavior of the MOSFETs. For that reason, the Demonstrator Board is shipped in low quiescent current mode – during initial evaluation the risk of damaging the MOSFETs through thermal runaway is thus reduced.

Nevertheless, by modifying one resistor value, the dead-time can be shortened and evaluation in enhanced sonic performance mode can take place. Changing R9 to a lower value decreases dead-time. It is left the responsibility of the experimenter to prevent thermal runaway, but assistance from Philips will be available through the local sales representatives.

To reduce the risk of thermal runaway in the enhanced sonic performance mode, a thermal feedback loop can be implemented: the operating temperature of the MOSFETs can be fed-back to the dead-time control by changing the fixed R9 value, mounting a PTC resistor on the heatsink of the MOSFETs and connecting the PTC in parallel with R9. Again, any changes are left the responsibility of the experimenter, but assistance from Philips will be available through the local sales representatives.

7. Legal information

7.1 Definitions

Draft — The document is a draft version only. The content is still under internal review and subject to formal approval, which may result in modifications or additions. Philips Semiconductors does not give any representations or warranties as to the accuracy or completeness of information included herein and shall have no liability for the consequences of use of such information.

7.2 Disclaimers

General — Information in this document is believed to be accurate and reliable. However, Philips Semiconductors does not give any representations or warranties, expressed or implied, as to the accuracy or completeness of such information and shall have no liability for the consequences of use of such information.

Right to make changes — Philips Semiconductors reserves the right to make changes to information published in this document, including without limitation specifications and product descriptions, at any time and without notice. This document supersedes and replaces all information supplied prior to the publication hereof.

Suitability for use — Philips Semiconductors products are not designed, authorized or warranted to be suitable for use in medical, military, aircraft, space or life support equipment, nor in applications where failure or

malfunction of a Philips Semiconductors product can reasonably be expected to result in personal injury, death or severe property or environmental damage. Philips Semiconductors accepts no liability for inclusion and/or use of Philips Semiconductors products in such equipment or applications and therefore such inclusion and/or use is at the customer's own risk.

Applications — Applications that are described herein for any of these products are for illustrative purposes only. Philips Semiconductors makes no representation or warranty that such applications will be suitable for the specified use without further testing or modification.

7.3 Patents

Notice is herewith given that the subject device uses one or more of the following patents and that each of these patents may have corresponding patents in other jurisdictions.

WO 03/090343 — owned by Koninklijke Philips Electronics N.V. (int. patent application)

7.4 Trademarks

Notice: All referenced brands, product names, service names and trademarks are the property of their respective owners.

8. Contents

1	Introduction	3
2	Circuit diagram	4
3	Printed-circuit board layout	5
4	Specifications	6
4.1	Pop-less/click-less start-up and shutdown	6
4.2	Overcurrent protection	6
4.3	Important notice	7
5	Wiring diagram and powering-up	7
6	Adding external features	8
6.1	Electronic enabling/disabling of the amplifier . .	8
6.2	Short-circuit and overcurrent protection	9
6.3	Sonic performance versus Efficiency trade-off	10
7	Legal information	11
7.1	Definitions	11
7.2	Disclaimers	11
7.3	Patents	11
7.4	Trademarks.....	11
8	Contents	12

Please be aware that important notices concerning this document and the product(s) described herein, have been included in section 'Legal information'.



© Koninklijke Philips Electronics N.V. 2006. All rights reserved.

For more information, please visit: <http://www.semiconductors.philips.com>.

For sales office addresses, email to: sales.addresses@www.semiconductors.philips.com.

Date of release: 5 September 2006

Document identifier: UM10155_2