

UM10386

SSL2102 19/22 W mains dimmable LED driver

Rev. 01 — 28 September 2009

User manual

Document information

Info	Content
Keywords	SSL2102, LED driver, AC/DC conversion, dimmable, driver, mains supply, user manual
Abstract	This is a user manual for the SSL2102 mains dimmable 19/22 W LED driver demo boards.

Revision history

Rev	Date	Description
01	20090928	First issue

Contact information

For more information, please visit: <http://www.nxp.com>

For sales office addresses, please send an email to: salesaddresses@nxp.com

1. Introduction

The SSL2102 19/22 W LED driver is a solution for a professional application with multiple high power LEDs that requires galvanic isolation and a safe output voltage. It is mains dimmable for both forward phase (triac) dimmers, and reverse phase (transistor) dimmers. It can generate up to 22 W output power, which is equal to a 150 W incandescent lamp (at 63 Lumen/W). Examples are shelf lighting, down lighting, LED lighting for bathrooms etc. The design gives an example of how to make a drive that is suitable for small form factor applications like retrofit lamps.

2. Safety warning

The board needs to be connected to mains voltage. Touching the reference board during operation must be avoided at all times. An isolated housing is obligatory when used in uncontrolled, non-laboratory environments. Even though the secondary circuit with LED connection has a galvanic isolation, this isolation is not according to any regulated norm. Galvanic isolation of the mains phase using a variable transformer is always recommended. These devices can be recognized by the symbols shown in [Figure 1](#):

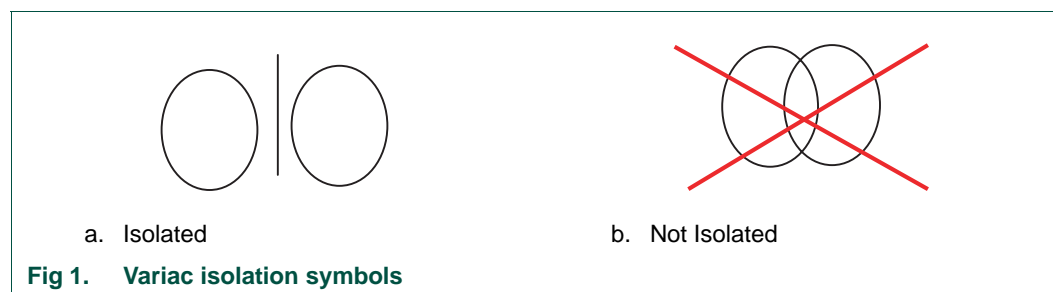

3. Connecting the board

The board can be optimized for a 230 V (AC) (50 Hz) or for a 120 V (AC) (60 Hz) mains source. Besides the mains voltage optimization, the board is designed to work with multiple high power LEDs with a total working voltage of between 9 V and 23 V. The output current can be limited using trimmer R20. On request, a dedicated LED load can be delivered that is to be connected to K3. Connector K2 can be used to attach other LED loads. The output voltage is limited to 25 V. When attaching a LED load to an operational board (hot plugging) an inrush peak current will occur due to discharge of capacitor C6. After frequent discharges, the LEDs may deteriorate or become damaged.

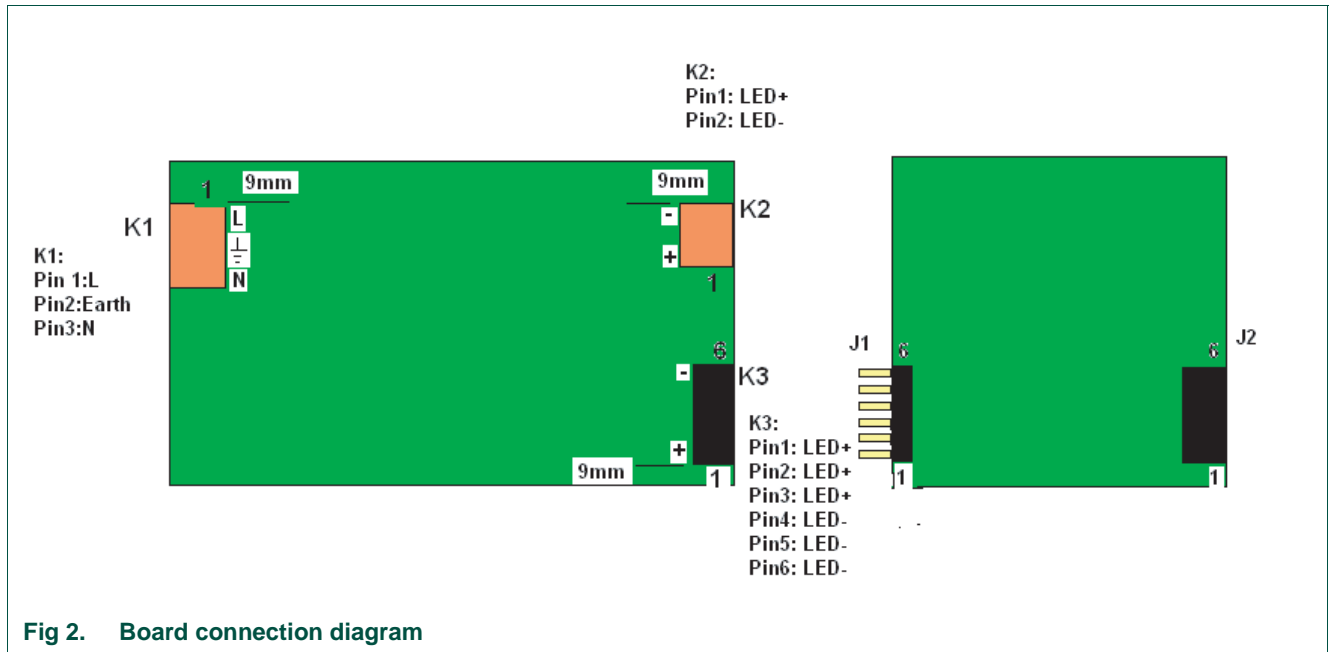

Fig 2. Board connection diagram

If a galvanic isolated transformer is used, it should be placed in between the AC source and the dimmer/demo board. Connect a user defined LED (string) to the connector K2 as shown in Figure 2. Note that the anode of the LED (string) is connected to the bottom side of this connector.

Remark: When the board is placed in a metal enclosure, the middle pin of connector K1 can be connected to the metal casing for grounding.

4. Specifications

Table 1 shows the specifications for the SSL2102 19/22 W LED driver

Table 1. Specifications

Parameter	Value	Comment
AC line input voltage	85 V (AC) to 276 V (AC)	Board has been optimized for 230 V (AC) or 120 V (AC) $\pm 10\%$ variation
Output voltage (LED voltage)	9 V (DC) to 23 V (DC)	
Output voltage protection	25 V (DC)	
Output current (LED current)	400 mA to 1050 mA	Adjustable with trimmer. The 120 V (AC) version is limited to 900 mA.
Output voltage /load current dependency	$< \pm 4\%$ / Volt in regulated range	See attached graphs
Current ripple	± 50 mA	at 500 mA
Maximum output power (LED power)	22 W	At $V_o + 21$ V. The 120 V (AC) version is limited to 19 W.
Efficiency	70 % to 78 %	At $T_{amb} = 25\text{ }^\circ\text{C}$ See Section 13 graphs

Table 1. Specifications ...continued

Parameter	Value	Comment
Power Factor:	0.99	at 19 W output power
120 V(AC), 230 V(AC)	0.97	at 22 W output power
Switching frequency	60 kHz to 75 kHz	
Dimming range	100 % to 0 %	
Board dimensions	103 mm × 50 mm × 20 mm	L × W × H
Operating temperature	0 °C to 85 °C	
Isolation voltage	± 4 KV	Between primary and secondary circuit
Input voltage /load current dependency	+5 % to -6 % in the range of 130 V (AC) to 110 V (AC), +3 % to -3 % in the range of 250 V (AC) to 210 V (AC)	

5. Board photos

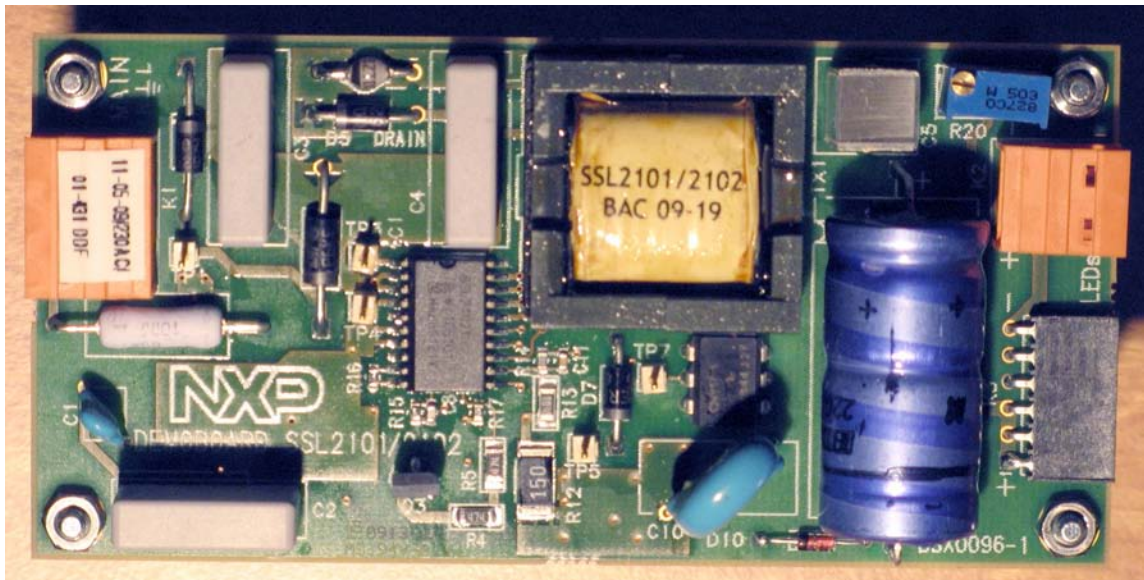

Fig 3. Demo board (top)

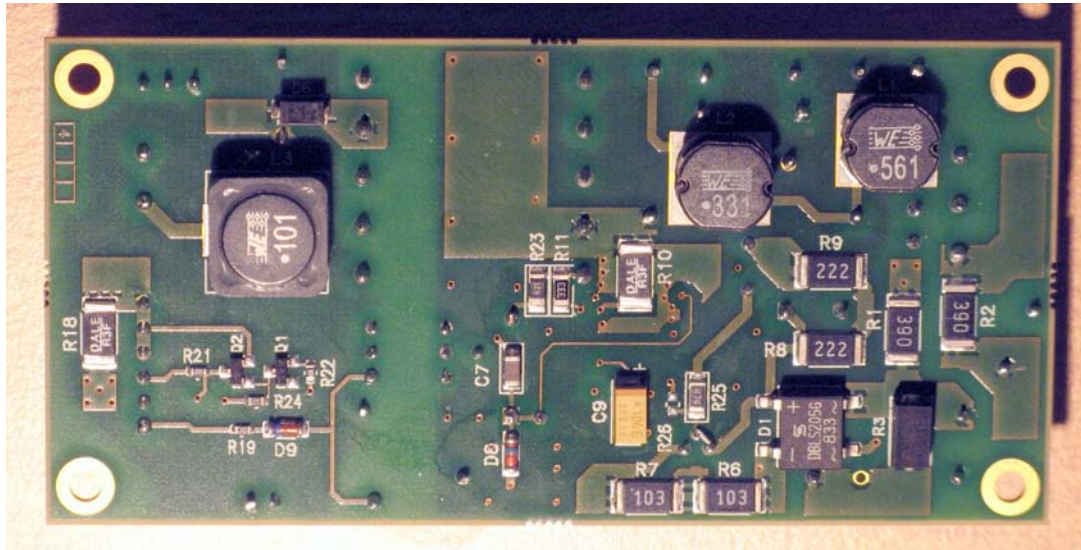

Fig 4. Demo board (bottom)

6. Dimmers

Several triac based dimmers have been tested by NXP Semiconductors. As different dimmers have different specifications, the dimming performance of the board may vary. [Table 2](#) shows the range of dimmers that have been tested with the board:

Table 2. Dimmer selection

Manufacturer	Type	Voltage V (AC)	Power range (W)	Load	Min. dimming range
Opus	852.390	230	60-400	Ha/Inc	0.6 %
Opus	852.392	230	20-500	Inc	0.05 %
Bush-Jaeger	2250U	230	20-600	Ha/Inc	0.03 %
Bush-Jaeger	2247U	230	20-500	Ha/Inc	0.07 %
Bush-Jaeger	6519U	230	40-550	Ha/Inc	8.4 %
Gira	1184	230	60-400	Inc	1 %
Everflourish	EFO700D	230	50-300	Ha/Inc	0.2 %
Drespa	0817	230	20-315	Ha/Inc	3.4 %
Ehmann	39 Domus	230	20-500	Ha/Inc	1 %
Drespa	815	230	20-500	Inc	1.1 %
Lutron	TG-600PH-WH	120	600	Inc	0 %(off)
Levitron	L12-6641-W	120	600	Inc	0 %(off)
Levitron	L02-700-W	120	600	Inc	0 %(off)
Levitron	6602-IW	120	600	Inc	0 %(off)
Levitron	6683-W	120	600	Inc	0 %(off)

Table 2. Dimmer selection ...continued

Manufacturer	Type	Voltage V (AC)	Power range (W)	Load	Min. dimming range
Levitron	R12-6631-LW	120	600	Inc	0 %(off)
Cooper	6001	120	600	Inc	0 %(off)
Lutron	MIR-600THW-WH	120	600	Ha/Inc	0.9 %

7. Functional description

The IC both controls and drives the flyback converter part, and ensures proper dimmer operation. Several high voltage switches are integrated in the IC. One of these controls the flyback input power, and is situated between the DRAIN and SOURCE pins. On closing, a current will start to run, which stores energy in the transformer TX1. The switch is opened when the duty factor has exceeded the level set by the PWMLIMIT pin, with a maximum of 75 %, or when the voltage on the SOURCE pin exceeds 0.5 V. Following this, the energy stored in the transformer is discharged to D6 and the output capacitors C5 and C6, and finally absorbed by the load. The converter frequency is set with an internal oscillator, the timing of which is controlled by external RC components on pins RC and RC2. By varying the BRIGHTNESS pin voltage, the oscillator frequency can be modulated to an upper and lower value. The ratio between R15 and R16 sets the frequency variation.

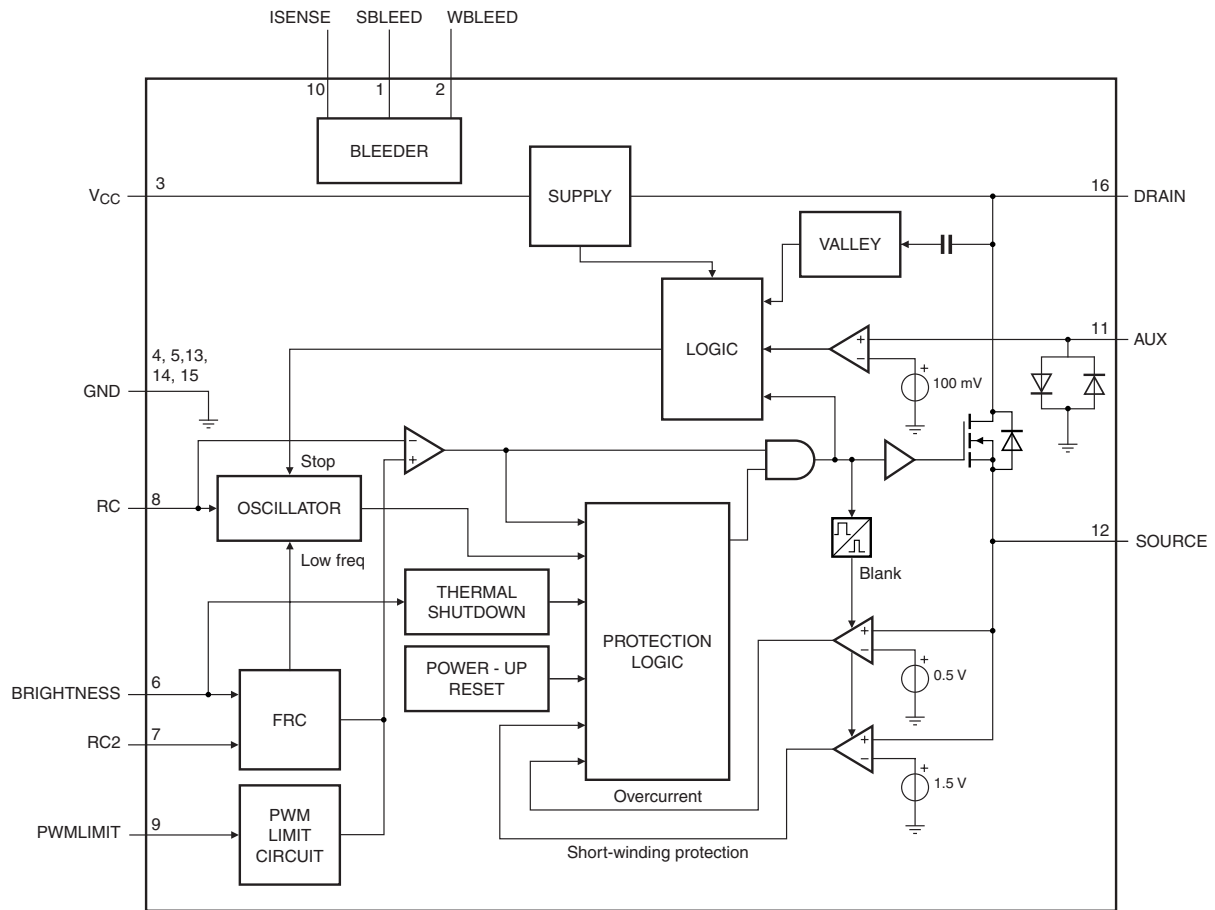

014aaa567

Fig 5. Block diagram SSL2102

The two other switches are called the weak bleeder (pin WBLEED), and the strong bleeder (pin SBLEED). When the voltage on both these pins is below a certain value (typical 52 V) the SBLEED switch closes, providing a current path that loads the dimmer during zero voltage crossing. This resets the dimmer timer. When the voltage on either of these pins is above 52 V, and the voltage on the ISENSE pin is above -100 mV, the weak bleeder switch closes. Using Q3, this current is boosted and provides a current path that loads the dimmer when the converter draws insufficient current to have the dimmer latching stable. Whilst the strong bleeder will always switch, the weak-bleeder will not activate until the output power drops below 8 W. This happens when the LEDs are dimmed, or when the maximum LED power is tuned below 8 W. See [Figure 6](#) and [Figure 7](#) that show bleeder voltage versus time in dimmed and un-dimmed position (low voltage = active):

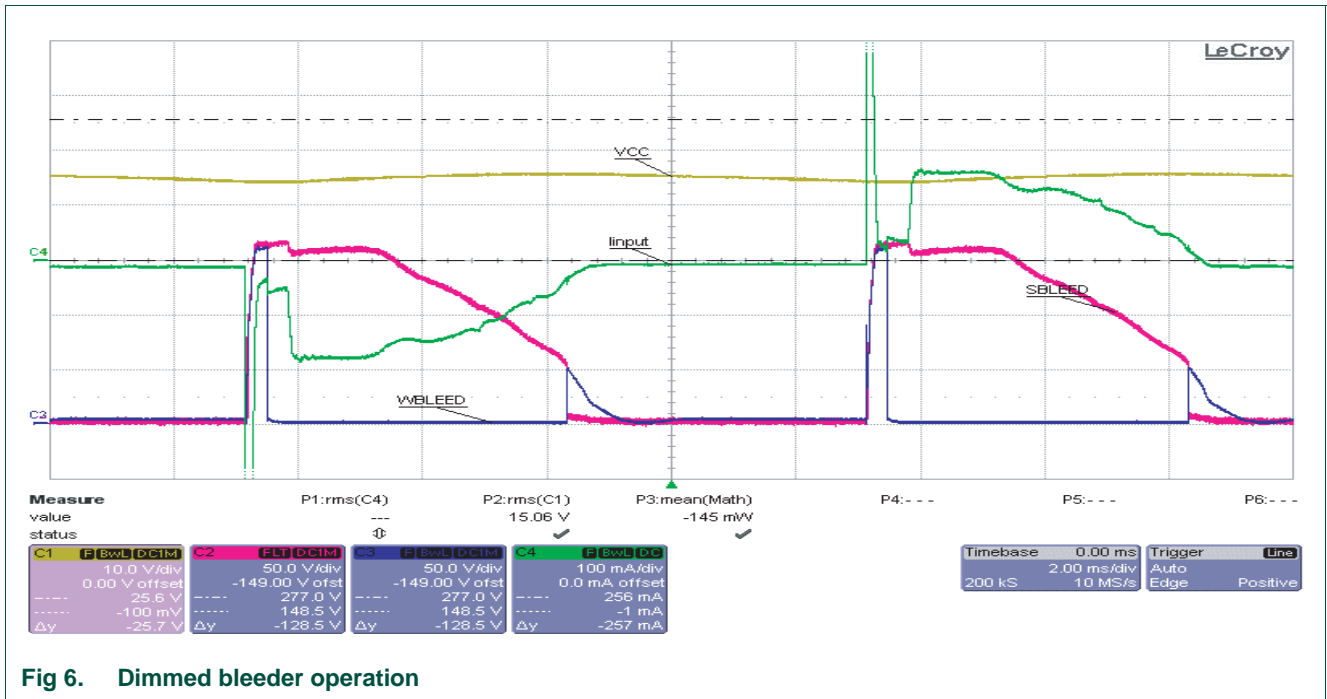

Fig 6. Dimmed bleeder operation

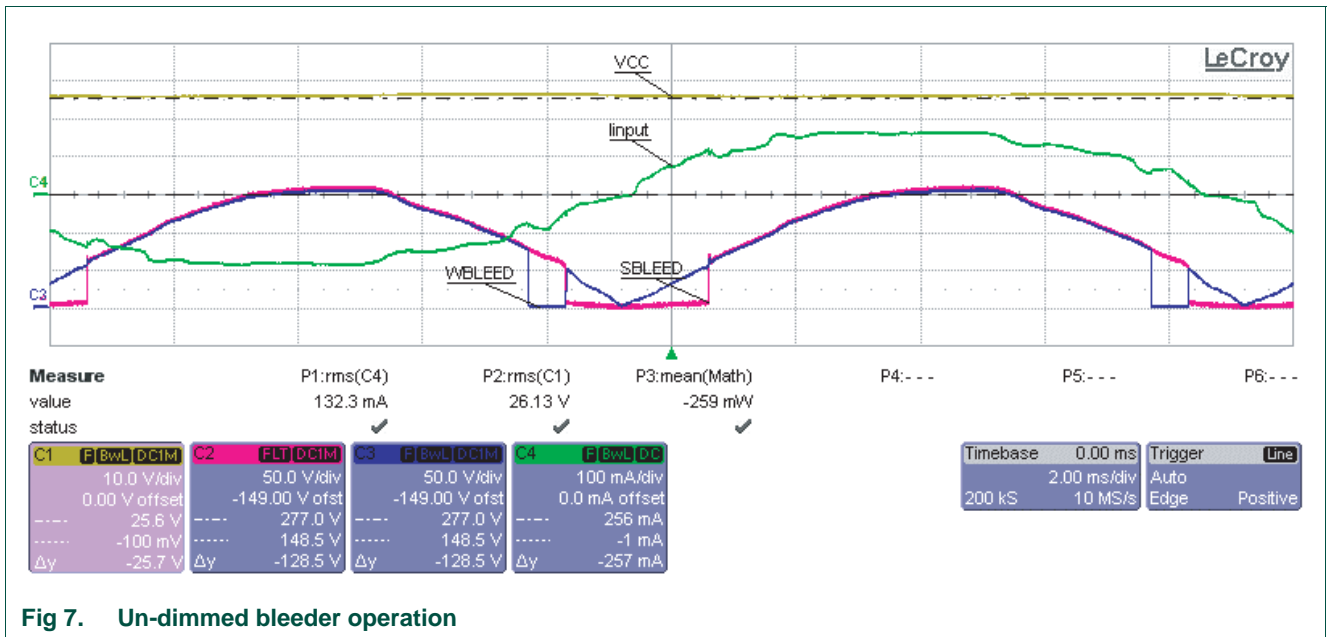

Fig 7. Un-dimmed bleeder operation

This board is optimized to work with a power factor above 0.9. In order to achieve this, the converter operates at constant t_{on} mode. The output power of the converter is buffered by capacitor C6. Due to this configuration, the circuit has a resistive input current behavior in un-dimmed operation (see Input in Figure 7). In dimmed operation however, not only the dimmer latch and hold current must be maintained, but a damper must be added to dampen the inrush current and to dissipate the electric power that was stored in the LC filter within the dimmer. Though at low power ranges (< 10 W) a serial resistor can be used for this, at higher power ranges a single series resistor is not efficient because the converter supply current will cause significant voltage drop and thus dissipation through

this resistor. On the demonstration board, a combination of serial resistance and a parallel damper has been chosen to improve efficiency. The serial resistor is made up of F1, R1, R2 and R12. The parallel damper is made of C2 and R3. See [Figure 8](#).

The input circuit of the converter must be equipped with a filter that is partially capacitive. The combination of C1, L1, L2, C3 and C4 makes a filter that blocks most of the disturbance generated by the converter input current. A drawback of this filter is a reduction of power factor, due to the capacitive load. A lower converter power in relation to the capacitive value of this filter/buffer will cause a lower power factor. At the 230 V (AC) design using 150 nF capacitors, a power factor of 0.9 is reached at 11 W output power.

The board is equipped with a feedback loop that limits the output current. This feedback loop senses the LED current over sense resistor R18 and a current mirror is used, consisting of Q1/Q2. Using R20, the current level can be set. The same feedback loop is also used for overvoltage protection. If the LED voltage exceeds 23 V, a current through R19 and D9 will start flowing. The current through the opto-coupler IC2 will pull down the PWMLIMIT and BRIGHTNESS pin. At a value below 400 mV, the “on”-time is zero. The feedback loop has proportional action only, and the gain is critical because of phase shift caused by the converter and C6. The relation between PWMLIMIT and output current is quadratic in nature. The resulting output current spread will be acceptable for most LED applications.

The dimming range is detected by sensing the average rectified voltage. R4, R5 and R17 make a voltage divider, and C9 filters the resulting signal. The converter sets its duty factor and converter frequency accordingly.

8. Board optimization

The following modifications can be done in order to meet different customer application requirements:

8.1 Changing the output voltage and LED current

Compared to other topologies, a flyback converter has the major advantage that it is suitable for driving a broader range of output voltages. Essentially, changing the winding ratio whilst maintaining the value of the primary inductance, will shift the output working voltage accordingly. Part of the efficiency of the driver is linked to the output voltage. A lower output voltage will increase the transformation ratio, and cause higher secondary losses. In practice, a mains dimmable flyback converter will have an efficiency between 80 % for high output voltages (like 60 V) down to 50 % for low output voltages (like 3 V). At low voltages, synchronous rectification might become advisable to reduce losses. The NXP TEA1791 can be applied for this purpose. For exact calculations of transformer properties and peak current, we refer to application note [Ref. 1](#) and the calculation tool that goes with it.

8.2 Changing the output ripple current

LED voltage, the LED dynamic resistance and the output capacitor mostly determine the output current ripple. The value of C6 has been chosen to optimize capacitor size with light output. A ripple of $\pm 25\%$ will result in an expected deterioration of light output $< 1\%$.

The size for the buffer capacitor can be estimated from the following equation

$$C6 = \frac{I}{\Delta I} \times \frac{1}{6 \times f_{net} \times R_{dynamic}}$$

As example: For a ripple current of $\pm 5\%$, and a mains frequency of 50 Hz, and a dynamic resistance of 0.6Ω , C6 has to be $20 \div (300 \times 0.6) = 111 \text{ mF}$. For a ripple current of 25% and a dynamic resistance of 6Ω , $4 \div (300 \times 6) = 2200 \mu\text{F}$. Using a series of LEDs, the dynamic resistance of each LED can be added to the total dynamic resistance.

8.3 Adapting to high power reverse phase (transistor) dimmers.

Reverse phase (transistor) dimmers differ in two ways that can be beneficial but can also cause problems with dimming detection:

- The negative phase-cut (trailing edge) causes no inrush current when the dimmer triggers. At triac dimmers, there will be a sudden voltage difference over the input leading to a steep charge of the input capacitors. The resulting peak current will lead to higher damper dissipation. Because this steep charge is missing, the input capacitors will have less stress, and the input circuit is less sensitive to audible noise.
- Transistor dimmers contain active circuitry that require a load charge during the time that the dimmer is open. The dimensioning of the circuit generating the internal supply voltage inside the dimmer is made critical in order to avoid excessive internal dimmer losses. This means that the remaining voltage drop over the lamp must be low enough to reach this charge. For dimmers like the Busch-Jaeger 6519U, the minimum lamp load is specified at 40 W which is equivalent to a $1.3 \text{ k}\Omega$ resistor load at 230 V(AC). Such a load would result in highly inefficient operation at low output power levels, since most energy is wasted in order to drive the dimmer, and not to produce light.

On the demo board, the weak bleeder value R6/R7 is chosen to minimize losses (about 2 W to 3 W). The weak bleeder normally only switches “on” during dimmed operation. The voltage drop with some transistor dimmers is however not sufficient to cause full dimming range control (minimum 10 % instead of $< 1\%$), because in this application, the average rectified voltage is used to determine the dimming position. To compensate for the reduced voltage difference, voltage detection can be made more sensitive by replacing R4 with a Zener diode, like the BZV85-C200 for 230 V(AC), or the BZV85-C68 for 120 V (AC) applications. Because of increased sensitivity, the dimming curve will also be steeper when using triac dimmers.

8.4 Changing the load curve

The load curve can be divided into two regions: A part where the control loop limits the duty cycle of the converter, and where the output current is regulated, and a part where the duty factor feedback is not dominant anymore. This last part occurs at output voltages below 13 V. In this area, constant output power becomes the dominant control mechanism. Changing the winding ratio of the transformer to match the output load will also change this load curve.

8.5 Multiple driver support

It is possible to attach multiple converters to a single dimmer. At the use of triac dimmers the inrush current will rise, though not proportionally to the number of converters. Transistor dimmers are more suitable for usage with multiple converters because the dimming range will increase due to the added bleeder action, and there is no inrush current.

9. Board schematic

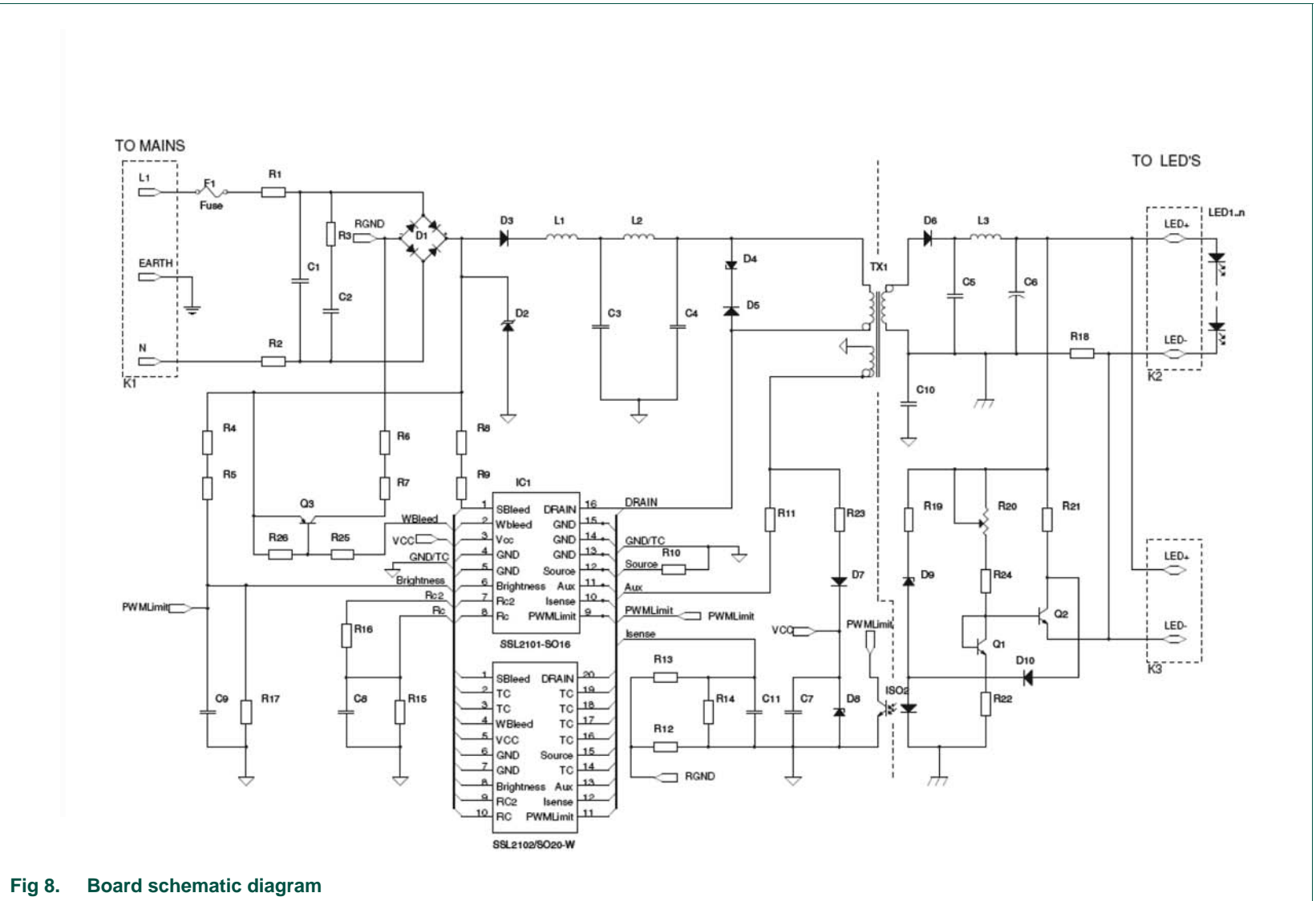

Fig 8. Board schematic diagram

10. Bill Of Materials (BOM)

Table 3. Bill of materials 230 V (AC)

Part No.	Ref. Des.	Part	Value	Pwr (W)	Tol. (%)	Volt (V)	Package	Type	Manuf.	Amount
1	K1	Conn 3 pin 2u ang	m	-	-	-	-	SL 5.08/3/90	Weidmuller	1
2	K1'	Conn 3 pin 2u	f	-	-	-	-	BL 5.08/3	Weidmuller	1
3	K3	Conn 6 pin 1u	f	-	-	-	-	BL3.36Z	Fischer	1
4	K2	Conn 2 pin 2u ang	m	-	-	-	-	SL 5.08/2/90	Weidmuller	1
5	K2'	Conn 2 pin 2u	f	-	-	-	-	BL 5.08/2	Weidmuller	1
6	F1	Fusistor	6.8E	1	10		Free	-	-	1
7	R1	Resistor	39 Ω	1	5		Free	-	-	1
8	R2	Resistor	39 W	1	5		Free	-	-	1
9	R3	Resistor	1 kW	2	5		Free	-	-	1
10	R4	Resistor	470 kW	0.25	1		Free	-	-	1
11	R5	Resistor	470 kW	0.25	1		Free	-	-	1
12	R6	Resistor	10 kW	1	5	200	Free	-	-	1
13	R7	Resistor	10 kW	1	5	200	Free	-	-	1
14	R8	Resistor	2.2 kW	1	5	200	Free	-	-	1
15	R9	Resistor	2.2kW	1	5	200	Free	-	-	1
16	R10	Resistor	0.4 W	1	1	-	Free	-	-	1
17	R11	Resistor	33 kW	0.25	5	200	Free	-	-	1
18	R12	Resistor	15 W	1	5	200	Free	-	-	1
19	R13	Resistor	100 kW	0.1	1	200	Free	-	-	1
20	R14	Resistor	22 kW	0.1	1	-	Free	-	-	1
21	R15	Resistor	470 kW	0.1	1	-	Free	-	-	1
22	R16	Resistor	4.7 kW	0.1	1	-	Free	-	-	1
23	R17	Resistor	12 kW	0.1	1	-	Free	-	-	1
24	R18	Resistor	0.3 W	1	1	-	Free	-	-	1
25	R19	Resistor	10 kW	0.1	5	-	Free	-	-	1
26	R20	Resistor	50 kW Lin	0.1	5	-	Horizontal	-	Bourns	1
27	R21	Resistor	22 kW	0.1	1	-	Free	-	-	1
28	R22	Resistor	330 W	0.1	1	-	Free	-	-	1
29	R23	Resistor	470 W	0.25	5	-	Free	-	-	1
30	R24	Resistor	3.9 kW	0.1	5	-	Free	-	-	1
31	R25	Resistor	470 kW	0.25	5	-	Free	-	-	1
32	R26	Resistor	10 kW	0.1	5	-	Free	-	-	1
33	C1	Capacitor	470 pF	-	10	1 K	Cer	DEBB33A471KC1B	Murata	1
34	C2	Capacitor	150 nF	-	10	400	Poly	NRM-S154K400F	NIC	1
35	C3	Capacitor	150 nF	-	10	400	Poly	NRM-S154K400F	NIC	1
36	C4	Capacitor	150 nF	-	10	400	Poly	NRM-S154K400F	NIC	1

Table 3. Bill of materials 230 V (AC) ...continued

Part No.	Ref. Des.	Part	Value	Pwr (W)	Tol. (%)	Volt (V)	Package	Type	Manuf.	Amount
37	C5	Capacitor	4.7 μ F	-	10	63	Poly	B32560J475K	Epcos	1
38	C6	Capacitor	2200 μ F	105°	10	25		2222 021 16222	Vishay	1
39	C7	Capacitor	4.7 μ F	105°	10	25	Free	-	-	1
40	C8	Capacitor	330 pF	Cer	5		Free	-	-	1
41	C9	Capacitor	10 μ F	105°	10	25	Free	-	-	1
42	C10	Capacitor	2.2 nF	-	10	4 K	Cer	DECE33J222ZC4B	Murata	1
43	C11	Capacitor	10 nF	-	10	25	Cer, Free	-	-	1
44	L1	Inductor	680 μ H	-	-	-	-	744776268	Würth	1
45	L2	Inductor	330 μ H	-	-	-	-	744776233	Würth	1
46	L3	Inductor	100 μ H	-	-	-	-	74477120	Würth	1
47	TX1	Transformer	N87/3F3	-	5		EFD25	750340505	Würth	1
48	D1	Rect Bridge	2 A	-	-	-	SO-4	DBLS205G	Taiwan semi	1
49	D2	TVS diode	600 W	-	-	-	-	P6KE400A	Fairchild	1
50	D3	Diode	1 A; 800 V	-	-	-	-	HER107	Taiwan semi	1
51	D4	Zener	270 V; 3 W	-	-	-	-	BZT03-C220	Vishay	1
52	D5	Diode	1 A; 800 V	-	-	-	-	HER107	Taiwan semi	1
53	D6	Diode	3 A; 100 V	-	-	-	-	SK310A	Taiwan semi	1
54	D7	Diode	1 A; 800 V	-	-	-	-	HER107	Taiwan semi	1
55	D8	Zener	30 V	-	5		-	BZV55-C30	NXP	1
56	D9	Zener	20 V	-	5		-	BZV55-C20	NXP	1
57	D10	Diode	75 V	-	-	-	-	1N4148	NXP	1
58	Q1	Transistor	NPN	-	-	-	-	BC847B	NXP	1
59	Q2	Transistor	NPN	-	-	-	-	BC847B	NXP	1
60	Q3	Transistor	PNP	-	-	-	-	ZTX758	Zetex	1
61	ISO2	Opto-coupler	-	-	-	-	-	CNY17-1	Fairchild	1
62	U1	IC	-	-	-	-	SO20	SSL2102	NXP	1

Table 4. Bill of materials 120 V (AC)

Part No.	Ref. Des.	Part	Value	Pwr (W)	Tol. (%)	Volt (V)	Package	Type	Manuf.	Amount
1	K1	Conn 3 pin 2u ang	m	-	-	-	-	SL 5.08/3/90	Weidmuller	1
2	K1'	Conn 3 pin 2u	f	-	-	-	-	BL 5.08/3	Weidmuller	1
3	K3	Conn 6 pin 1u	f	-	-	-	-	BL3.36Z	Fischer	1
4	K2	Conn 2 pin 2u ang	m	-	-	-	-	SL 5.08/2/90	Weidmuller	1
5	K2'	Conn 2 pin 2u	f	-	-	-	-	BL 5.08/2	Weidmuller	1

Table 4. Bill of materials 120 V (AC) ...continued

Part No.	Ref. Des.	Part	Value	Pwr (W)	Tol. (%)	Volt (V)	Package	Type	Manuf.	Amount
6	F1	Fusistor	6.8E	1	10	-	Free	-	-	1
7	R1	Resistor	15 W	1	5	-	Free	-	-	1
8	R2	Resistor	15 W	1	5	-	Free	-	-	1
9	R3	Resistor	1.2 kW	1	5	-	Free	-	-	1
10	R4	Resistor	470 kW	0.25	1	-	Free	-	-	1
11	R5	Resistor	0 W	0.25	5	-	Free	-	-	1
12	R6	Resistor	2.7 kW	1	5	200	Free	-	-	1
13	R7	Resistor	2.7 kW	1	5	200	Free	-	-	1
14	R8	Resistor	1 kW	1	5	200	Free	-	-	1
15	R9	Resistor	1 kW	1	5	200	Free	-	-	1
16	R10	Resistor	0.3 W	1	1	-	Free	-	-	1
17	R11	Resistor	33 kW	0.25	5	200	Free	-	-	1
18	R12	Resistor	10 W	1	5	200	Free	-	-	1
19	R13	Resistor	100 kW	0.1	1	200	Free	-	-	1
20	R14	Resistor	15 kW	0.1	1	-	Free	-	-	1
21	R15	Resistor	470 kW	0.1	1	-	Free	-	-	1
22	R16	Resistor	10 kW	0.1	1	-	Free	-	-	1
23	R17	Resistor	12 kW	0.1	1	-	Free	-	-	1
24	R18	Resistor	0.3 W	1W	1	-	Free	-	-	1
25	R19	Resistor	10 kW	0.1	5	-	Free	-	-	1
26	R20	Resistor	50 kW Lin	0.1	5	-	Horizontal	-	Bourns	1
27	R21	Resistor	22 kW	0.1	1	-	Free	-	-	1
28	R22	Resistor	330 W	0.1	1	-	Free	-	-	1
29	R23	Resistor	3.9 kW	0.25	5	-	Free	-	-	1
30	R24	Resistor	3.9 kW	0.1	5	-	Free	-	-	1
31	R25	Resistor	100 kW	0.25	5	-	Free	-	-	1
32	R26	Resistor	NP	-	-	-	Free	-	-	1
33	C1	Capacitor	470 pF	-	10	1 KV	Cer	DEBB33A471KC1B	Murata	1
34	C2	Capacitor	220 nF	-	10	400	Poly	NRM-S104K400F	NIC	1
35	C3	Capacitor	330 nF	-	10	400	Poly	NRM-S334K400F	NIC	1
36	C4	Capacitor	330 nF	-	10	400	Poly	NRM-S334K400F	NIC	1
37	C5	Capacitor	4.7 μF	-	10	63	Poly	B32560J475K	Epcos	1
38	C6	Capacitor	2200 μF	105°	10	25	-	2222 021 16222	Vishay	1
39	C7	Capacitor	4.7 μF	105°	10	25	Free	-	-	1
40	C8	Capacitor	330 pF	-	5		Cer, Free	-	-	1
41	C9	Capacitor	10 μF	105°	10	25	Free	-	-	1
42	C10	Capacitor	2.2 nF	-	10	4 K	Cer	DECE33J222ZC4B	Murata	1
43	C11	Capacitor	10 nF	-	10	25	Cer, Free	-	-	1
44	L1	Inductor	680 μH	-	-	-	-	744776268	Würth	1

Table 4. Bill of materials 120 V (AC) ...continued

Part No.	Ref. Des.	Part	Value	Pwr (W)	Tol. (%)	Volt (V)	Package	Type	Manuf.	Amount
45	L2	Inductor	330 μ H	-	-	-	-	744776233	Wurth	1
46	L3	Inductor	100 μ H	-	-	-	-	74477120	Wurth	1
47	TX1	Transformer	N87/3F3	-	5 %	-	EFD25	750340505	Wurth	1
48	D1	Rect Bridge	2 A	-	-	-	SO-4	DBLS205G	Taiwan semi	1
49	D2	TVS diode	600 W	-	-	-	-	P6KE270A	Fairchild	1
50	D3	Diode	1 A; 800 V	-	-	-	-	HER107	Taiwan semi	1
51	D4	Zener	270 V; 3 W	-	-	-	-	BZT03-C220	Vishay	1
52	D5	Diode	1 A; 800 V	-	-	-	-	HER107	Taiwan semi	1
53	D6	Diode	3 A; 100 V	-	-	-	-	SK310A	Taiwan semi	1
54	D7	Diode	1 A; 800 V	-	-	-	-	HER107	Taiwan semi	1
55	D8	Zener	30 V	-	5 %	-	-	BZV55-C30	NXP	1
56	D9	Zener	20 V	-	5 %	-	-	BZV55-C20	NXP	1
57	D10	Diode	75 V	-	-	-	-	1N4148	NXP	1
58	Q1	Transistor	NPN	-	-	-	-	BC847B	NXP	1
59	Q2	Transistor	NPN	-	-	-	-	BC847B	NXP	1
60	Q3	Transistor	PNP	-	-	-	-	MPSA92	NXP	1
61	ISO2	Optocoupler	-	-	-	-	-	CNY17-1	Fairchild	1
62	U1	IC	-	-	-	-	SO20	SSL2102T	NXP	1

11. Transformer specification

Figure 9 shows the transformer schematic:

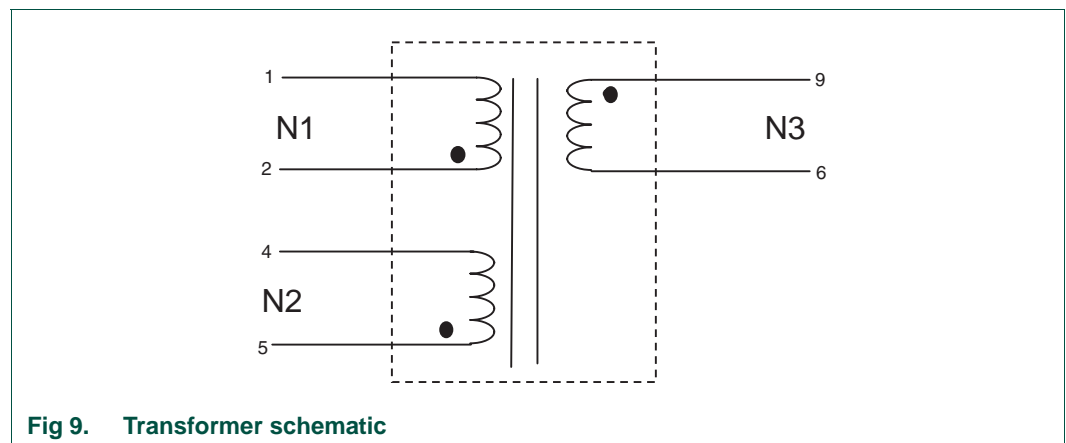

11.1 Winding specification

Table 5. Winding specification

No.	Section	Wire	Layers	Turns	Pin	
					Begin	End
1	N1	1 × 0.315	1	43	2	
2	ISO	0.2				
3	N3	40 × 0.071	1	21	9	6
4	ISO	0.2				
5	N2	1 × 0.2	1	42	5	4
6	ISO	0.2				
7	N1	1 × 0.315	1	42		1
8	ISO	0.2				

11.2 Electrical characteristics

Table 6. Inductance

Section	Inductance
N1	910 μH ± 5 %, at 2.3 A
N2	70 μH
N3	270 μH

- Nominal frequency = 100 kHz
- Breakdown voltage V_{BR} N1...N2 = 4 KV

11.3 Core and bobbin

- Core: EFD25, 3F3/N87, airgap center 1100 μm
- Bobbin: CSH-EFD25-1S-10P

11.4 Physical dimensions

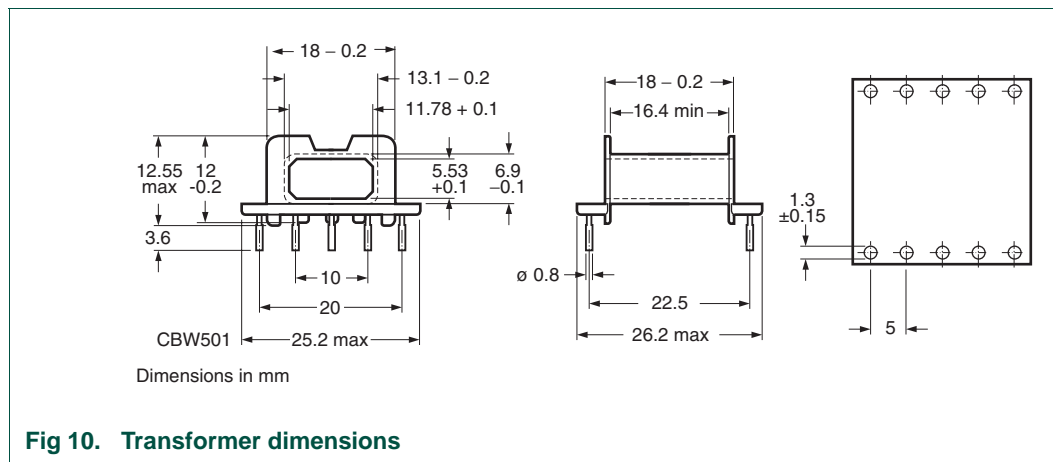

12. Appendix A - Load curves

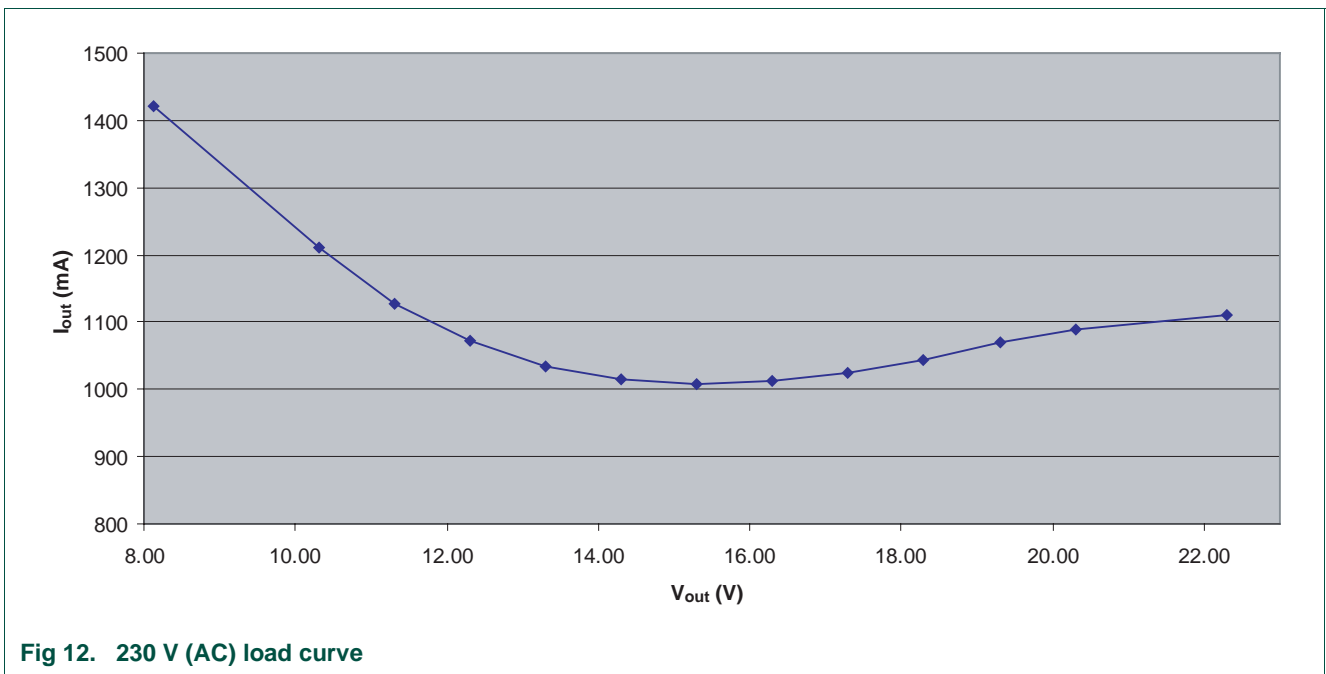
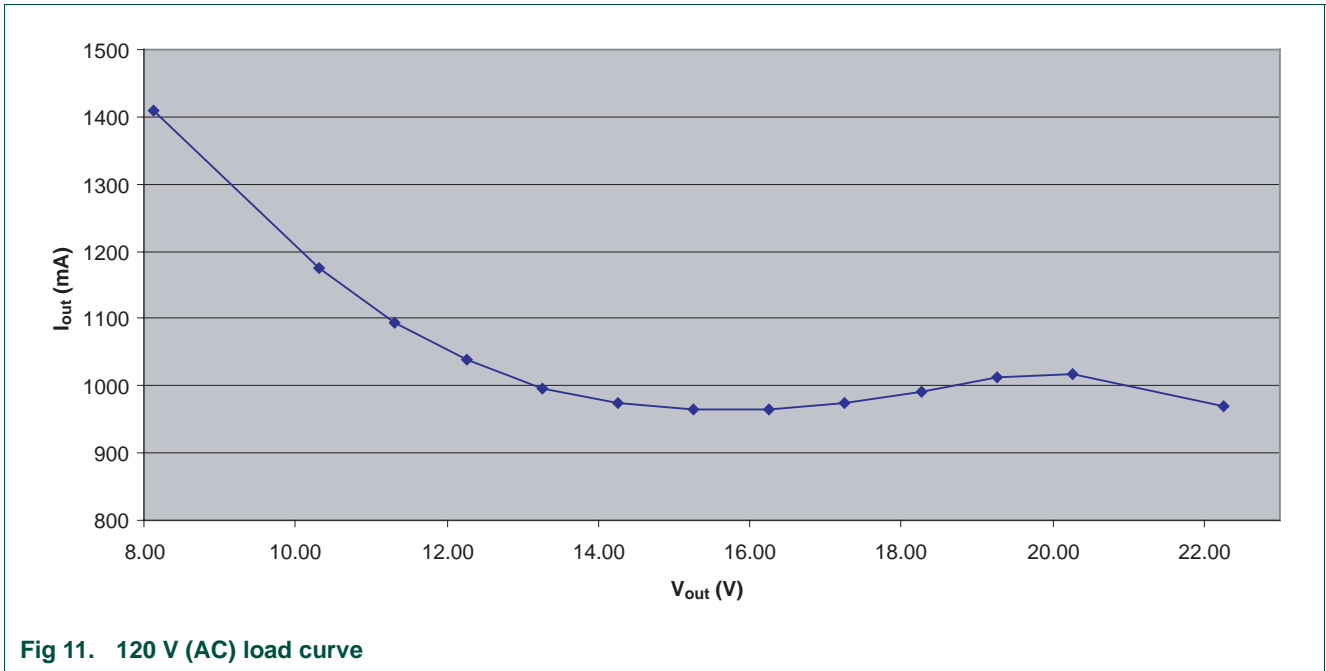

13. Appendix B - Efficiency curves

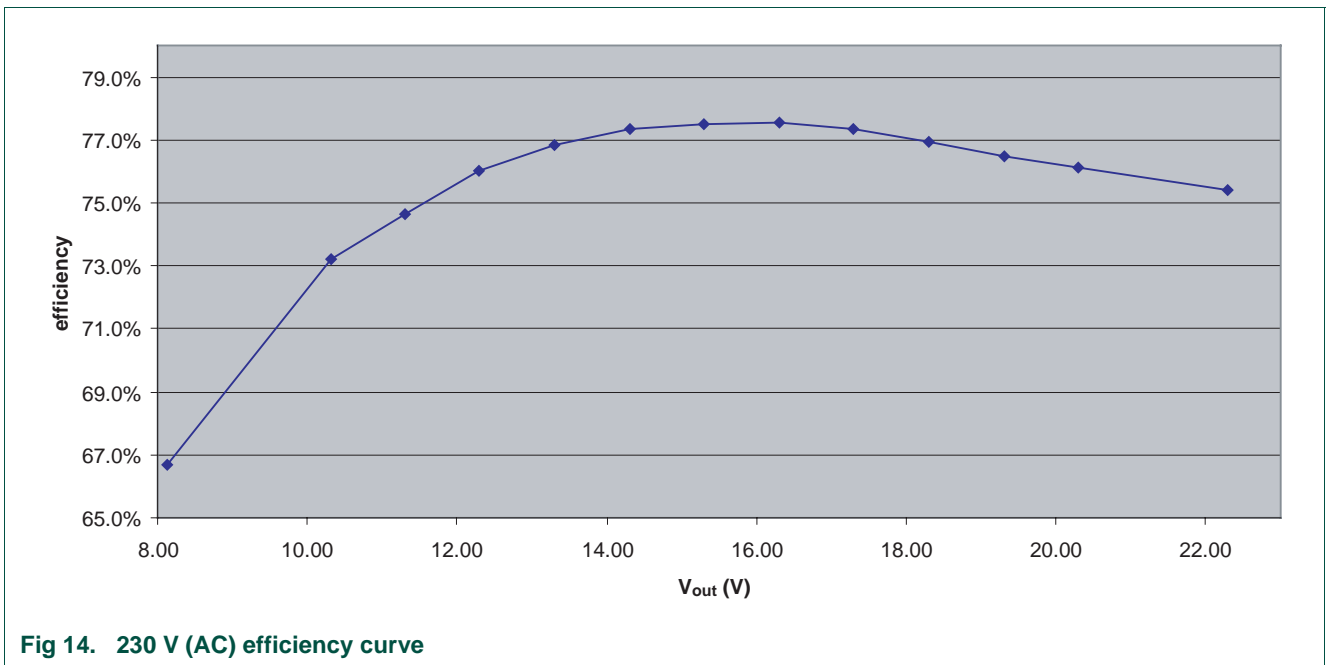
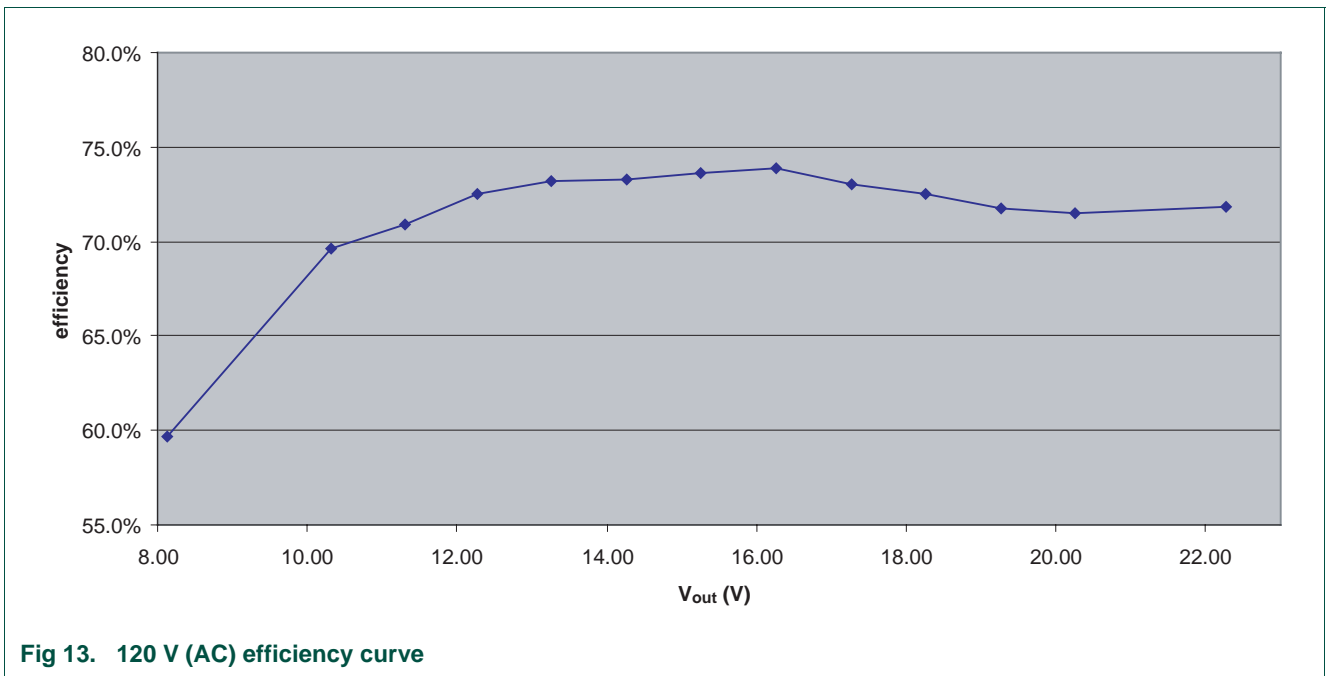

14. Appendix C - Input voltage dependency

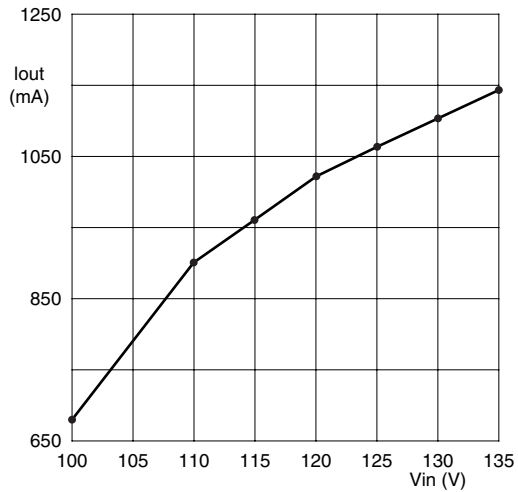

a. 120 V (AC) Input voltage dependency

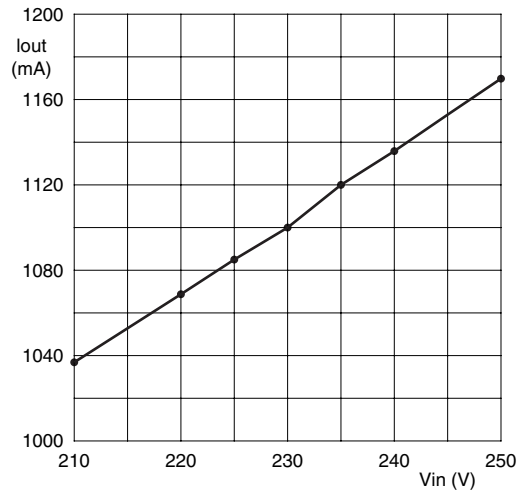

b. 230 V (AC) Input voltage dependency

Fig 15. Input voltage/output current dependency

15. Appendix D - Mains conducted harmonics

Table 7. Mains conducted harmonic values

Harmonic	230 V (AC) 50 Hz amplitude (%)	120 V (AC) 60 Hz amplitude (%)
PF	0.97	0.99
1	100	100
2	0	0
3	13.6	10.7
4	0	0
5	5.5	3.7
6	0	0
7	1.6	0.9
8	0.2	0
9	2.5	1.9
10	0	0
11	1.1	0.6
12	0	0
13	2.5	1.7
14	0	0
15	1.7	1.1
16	0	0
17	0.9	0.2

Table 7. Mains conducted harmonic values ...continued

Harmonic	230 V (AC) 50 Hz amplitude (%)	120 V (AC) 60 Hz amplitude (%)
18	0	0.1
19	2.9	0.8
20	0	0

16. References

- [1] **AN10831** — SSL2102 dimmable mains LED driver.
- [2] **SSL2102** — Data sheet
- [3] **SMPS** — IC for dimmable LED lighting

17. Legal information

17.1 Definitions

Draft — The document is a draft version only. The content is still under internal review and subject to formal approval, which may result in modifications or additions. NXP Semiconductors does not give any representations or warranties as to the accuracy or completeness of information included herein and shall have no liability for the consequences of use of such information.

17.2 Disclaimers

General — Information in this document is believed to be accurate and reliable. However, NXP Semiconductors does not give any representations or warranties, expressed or implied, as to the accuracy or completeness of such information and shall have no liability for the consequences of use of such information.

Right to make changes — NXP Semiconductors reserves the right to make changes to information published in this document, including without limitation specifications and product descriptions, at any time and without notice. This document supersedes and replaces all information supplied prior to the publication hereof.

Suitability for use — NXP Semiconductors products are not designed, authorized or warranted to be suitable for use in medical, military, aircraft, space or life support equipment, nor in applications where failure or malfunction of an NXP Semiconductors product can reasonably be expected to result in personal injury, death or severe property or environmental damage. NXP Semiconductors accepts no liability for inclusion and/or use of NXP Semiconductors products in such equipment or applications and therefore such inclusion and/or use is at the customer's own risk.

Applications — Applications that are described herein for any of these products are for illustrative purposes only. NXP Semiconductors makes no representation or warranty that such applications will be suitable for the specified use without further testing or modification.

Export control — This document as well as the item(s) described herein may be subject to export control regulations. Export might require a prior authorization from national authorities.

17.3 Trademarks

Notice: All referenced brands, product names, service names and trademarks are the property of their respective owners.

18. Contents

1	Introduction	3
2	Safety warning	3
3	Connecting the board	3
4	Specifications	4
5	Board photos	5
6	Dimmers	6
7	Functional description	7
8	Board optimization	10
8.1	Changing the output voltage and LED current	10
8.2	Changing the output ripple current	10
8.3	Adapting to high power reverse phase (transistor) dimmers	11
8.4	Changing the load curve	11
8.5	Multiple driver support	12
9	Board schematic	13
10	Bill Of Materials (BOM)	14
11	Transformer specification	17
11.1	Winding specification	18
11.2	Electrical characteristics	18
11.3	Core and bobbin	18
11.4	Physical dimensions	18
12	Appendix A - Load curves	19
13	Appendix B - Efficiency curves	20
14	Appendix C - Input voltage dependency . . .	21
15	Appendix D - Mains conducted harmonics . .	21
16	References	22
17	Legal information	23
17.1	Definitions	23
17.2	Disclaimers	23
17.3	Trademarks	23
18	Contents	24

Please be aware that important notices concerning this document and the product(s) described herein, have been included in section 'Legal information'.

founded by

PHILIPS

© NXP B.V. 2009.

All rights reserved.

For more information, please visit: <http://www.nxp.com>

For sales office addresses, please send an email to: salesaddresses@nxp.com

Date of release: 28 September 2009

Document identifier: UM10386_1