



NXP PNP low V_{CEsat} BISS/Trench MOSFET module PBSM5240PF in SOT1118

Unique 2-in-1 solution in an ultra-small leadless SOT1118 package

This groundbreaking solution enables slim mobile devices and delivers best-in-class thermal performance to support higher currents and longer lifetimes.

Key features and benefits

- ▶ Smaller PCB area than for conventional transistors
- ▶ Very low collector-emitter saturation voltage V_{CEsat}
- ▶ High collector current capability I_C and I_{CM}
- ▶ High collector current gain (h_{FE}) at high I_C
- ▶ High energy efficiency due to less heat generation
- ▶ Low-voltage MOSFET driver stage

Applications

- ▶ Loadswitches
- ▶ Battery-driven devices
- ▶ Power management
- ▶ Charging circuits
- ▶ Power switches (motors, fans, etc.)

The NXP PBSM5240PF combines a PNP low V_{CEsat} Breakthrough in Small Signal (BISS) transistor and an N-channel Trench MOSFET. The device is housed in a leadless, medium-power SOT1118 Surface-Mounted Device (SMD) plastic package.

With a footprint of only 2 x 2 mm and a height of just 0.65 mm, the SOT1118 offers great opportunities for the miniaturization of high-performance end products.

Compared to conventional solutions, which require two packages for the BISS/MOSFET solution, the PBSM5240PF offers a more than 50% reduction in footprint and a more than 10% lower package height. Also, because the SOT1118 incorporates a heat sink, the device delivers 25% better thermal performance, which leads to higher currents and longer lifetimes.

Size comparison: discrete solution

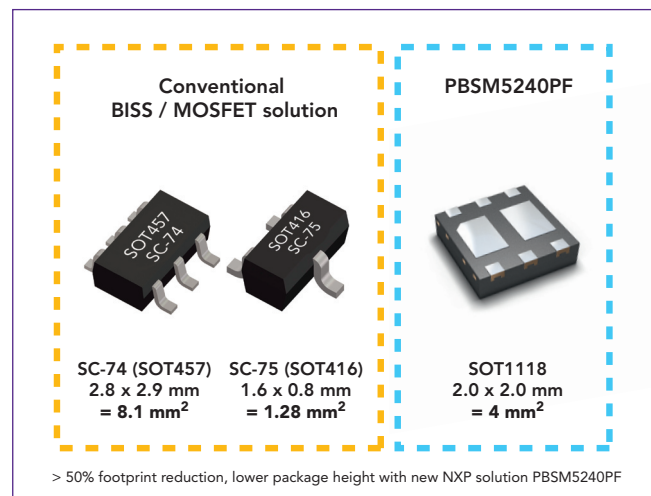

PNP low V_{CEsat} BISS/Trench MOSFET module in SOT1118

SOT1118 package	PNP low V_{CEsat} (BISS) transistor				N-channel Trench MOSFET				
	V_{CE0} (V)	I_{CRM} (A)	$h_{FE} \text{ min}$	$h_{FE} \text{ max}$	$R_{CEsat, typ}$ (m Ω) @ $I_C = 500 \text{ mA}$, $I_B = 50 \text{ mA}$	V_{DS} (V)	V_{GS} (V)	I_D (A)	$R_{DSon, typ}$ (m Ω)
PBSM5240PF	40	2	300	800	240	30	0.7	0.66	370

Application example

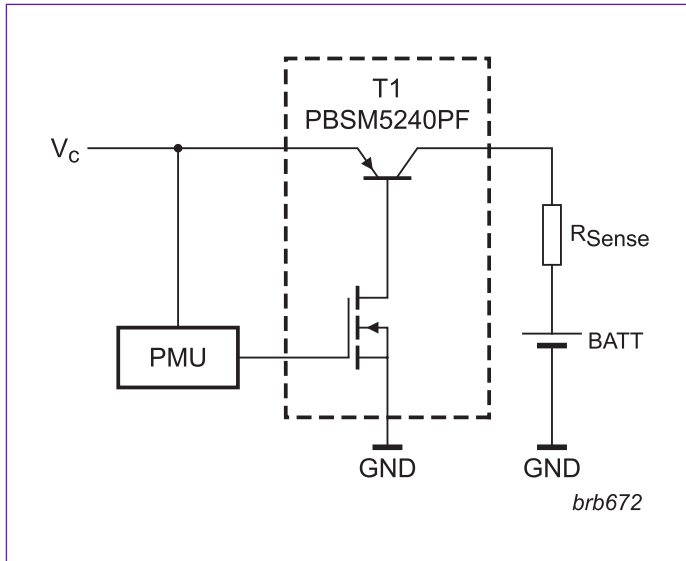

SOT1118 minimized outline

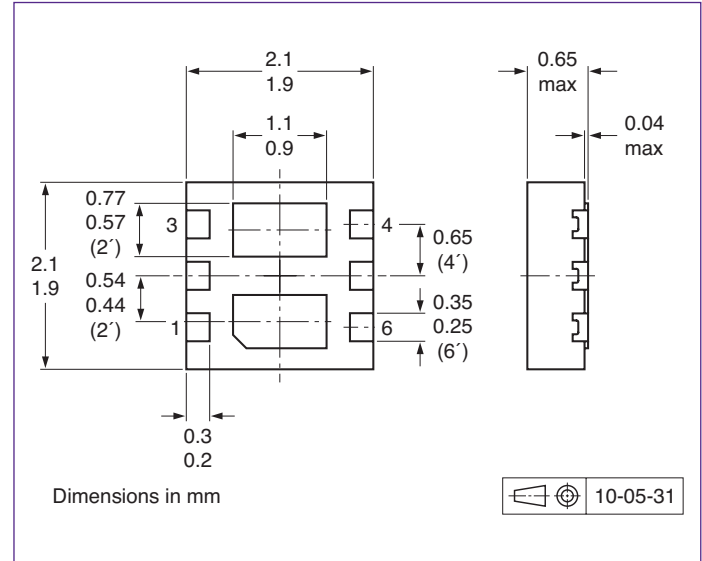

Size comparison: other suppliers

