

LED DRIVERS

VOLTAGE-SWITCH CONTROLLERS
AND CONSTANT-CURRENT DRIVERS

LED DRIVERS OVERVIEW

LEDs are used in a wide range of applications, from low-end status indicators to high-end video displays. System designers often need the ability to control these LEDs, but can't afford to tie up the system processor to do so. NXP's LED drivers solve this problem, performing a variety of control tasks while offloading the system processor. Having sent instructions to the LED driver, the processor is free to engage in other tasks or go into a low-power state.

NXP's LED drivers offer a variety of features needed in LED-driving applications. Some of these features include:

- Blinking and dimming capability
- Pulse-width modulation (PWM) for LED brightness control
- Color mixing capabilities
- Fast-mode Plus (Fm+) bi-directional communication channel with data transfer rate of up to 1 Mbit/s over the I²C-bus
- SPI-compatible 4-wire serial uni-directional interface with data transfer rate of up to 25 Mbit/s over serial peripheral interface (SPI)
- Different output types (push-pull, open-drain voltage switch or constant-current)
- Independent control of LEDs

The devices are classified in two groups: voltage-switch controllers and constant-current drivers. These groups are discussed below.

VOLTAGE-SWITCH CONTROLLERS

Voltage-switch output controllers devices control the LED connected to the output pin by switching the connection to ground or supply on or off. A series resistor connected between the LED and the device limits the current that flows through the LED into the device.

Voltage-switch devices have the advantage of dissipating the heat outside the device, in the series resistor. Therefore, the device is insensitive to heat dissipation and is good for driving multiple LEDs in series, with different forward-bias voltages (V_f), from the same supply.

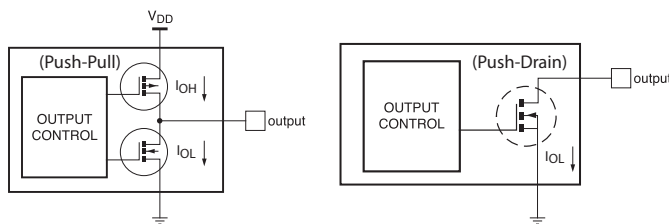

(a) Example Voltage-Switch Output Structure

CONSTANT-CURRENT DRIVERS

A current-regulated LED driver controls the current internally which results in the LED light remaining constant even with supply-voltage fluctuations. NXP constant-current LED drivers are used for low-current luminary lighting applications requiring accurate lighting control independent of supply voltage, temperature, and LED forward-bias voltage.

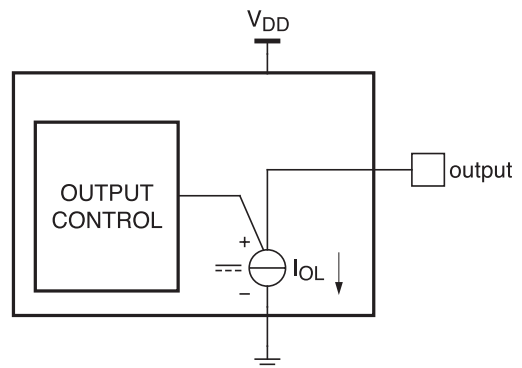

(b) Example Constant-Current Output Structure

The LED drivers are supported by application boards and daughter cards, an established manufacturing infrastructure that supports high volumes and technical documents. NXP helps system designers make lighting affordable, in everything from indoor consumer electronics and appliances to outdoor decorative lighting.

LED DRIVERS SELECTION GUIDE

Device	Function	Number of LED Outputs	Operating Voltage Range	Standby Current ⁽¹⁾	Type of LED Drive	Max LED Drive Current	Max LED Drive Voltage	Output Type	LED Pin Can Be Used as Input	Number of PWMs	Individual PWM Resolution (Steps)	Group PWM Resolution (Steps)	Individual Brightness Control	Group Brightness Control	Output Enable/PWM Control	Programmable Output Delay	LED Error Detection	Thermal Shutdown	Interface	Number of Device Addresses	Hardware Reset	Individual PWM Frequency	Group PWM Frequency	Status
PCA9530	Dimmer & blinker	2	2.3 V–5.5 V	1.9 μ A	Voltage switch	25 mA	5 V	Open drain (Sink)	Y	2	256	N/A	Y	N	N	N	N	N	I ² C, Fm	2	Y	0.591 Hz - 152 Hz	N/A	In production
PCA9531	Dimmer & blinker	8	2.3 V–5.5 V	1.9 μ A	Voltage switch	25 mA	5 V	Open drain (Sink)	Y	2	256	N/A	N	N	N	N	N	N	I ² C, Fm	8	Y	0.591 Hz - 152 Hz	N/A	In production
PCA9532	Dimmer & blinker	16	2.3 V–5.5 V	2.1 μ A	Voltage switch	25 mA	5 V	Open drain (Sink)	Y	2	256	N/A	N	N	N	N	N	N	I ² C, Fm	8	Y	0.591 Hz - 152 Hz	N/A	In production
PCA9533	Dimmer & blinker	4	2.3 V–5.5 V	1.9 μ A	Voltage switch	25 mA	5 V	Open drain (Sink)	Y	2	256	N/A	N	N	N	N	N	N	I ² C, Fm	1	N	0.591 Hz - 152 Hz	N/A	In production
PCA9550	Blinker	2	2.3 V–5.5 V	1.9 μ A	Voltage switch	25 mA	5 V	Open drain (Sink)	Y	2	256	N/A	Y	N	N	N	N	N	I ² C, Fm	2	Y	0.172 Hz - 44 Hz	N/A	In production
PCA9551	Blinker	8	2.3 V–5.5 V	1.9 μ A	Voltage switch	25 mA	5 V	Open drain (Sink)	Y	2	256	N/A	N	N	N	N	N	N	I ² C, Fm	8	Y	0.172 Hz - 44 Hz	N/A	In production
PCA9552	Blinker	16	2.3 V–5.5 V	2.1 μ A	Voltage switch	25 mA	5 V	Open drain (Sink)	Y	2	256	N/A	N	N	N	N	N	N	I ² C, Fm	8	Y	0.172 Hz - 44 Hz	N/A	In production
PCA9553	Blinker	4	2.3 V–5.5 V	1.9 μ A	Voltage switch	25 mA	5 V	Open drain (Sink)	Y	2	256	N/A	N	N	N	N	N	N	I ² C, Fm	1	N	0.172 Hz - 44 Hz	N/A	In production
PCA9632	RGB Color Mixing	4	2.3 V–5.5 V	0.005 μ A	Voltage switch	-10 mA 25 mA	5 V	Push/pull (Configurable)	N	4 + 1	256	64	Y	Y	N	N	N	N	I ² C, Fm+	1, 4	N	1.56 kHz	190 Hz (6.25 kHz)	In production
PCA9633	RGB Color Mixing	4	2.3 V–5.5 V	3.8 μ A	Voltage switch	-10 mA 25 mA	5 V	Push/pull (Configurable)	N	4 + 1	256	256	Y	Y	Y	N	N	N	I ² C, Fm+	1, 4, 126	N	97 kHz	190 Hz (97 kHz)	In production
PCA9634	RGB Color Mixing	8	2.3 V–5.5 V	3.8 μ A	Voltage switch	-10 mA 25 mA	5 V	Push/pull (Configurable)	N	8 + 1	256	256	Y	Y	Y	N	N	N	I ² C, Fm+	126	N	97 kHz	190 Hz (97 kHz)	In production
PCA9635 ⁽³⁾	RGB Color Mixing	16	2.3 V–5.5 V	3.8 μ A	Voltage switch	-10 mA 25 mA	5 V	Push/pull (Configurable)	N	16 + 1	256	256	Y	Y	Y	N	N	N	I ² C, Fm+	126	N	97 kHz	190 Hz (97 kHz)	In production
PCA9685 ^{(2) (3)}	RGB Color Mixing	16	2.3 V–5.5 V	2.2 μ A	Voltage switch	-10 mA 25 mA	5 V	Push/pull (Configurable)	N	16	4096	N/A	Y	N	Y	Y	N	N	I ² C, Fm+	62	N	24 Hz - 1526 Hz	N/A	In production
PCA9745B ⁽³⁾	RGB Color Mixing	16	3.0 V–5.5 V	170 μ A	Constant current	57 mA	20 V	Open drain (Sink)	N	16 + 1	256	256	Y	Y	Y	Y	N	Y	SPI 25 MHz	25	Y	31.5 kHz	122 Hz	In production
PCA9952 ⁽⁴⁾	RGB Color Mixing	16	3.0 V–5.5 V	100 μ A	Constant current	57 mA	40 V	Open drain (Sink)	N	16 + 1	256	256	Y	Y	Y	Y	Y	Y	I ² C, Fm+	8	Y	31.5 kHz	122 Hz	In production
PCA9955 ⁽⁴⁾	RGB Color Mixing	16	3.0 V–5.5 V	100 μ A	Constant current	57 mA	40 V	Open drain (Sink)	N	16 + 1	256	256	Y	Y	N	Y	Y	Y	I ² C, Fm+	16	Y	31.5 kHz	122 Hz	In production
PCA9955B ⁽³⁾	RGB Color Mixing	16	3.0 V–5.5 V	170 μ A	Constant current	57 mA	20 V	Open drain (Sink)	N	16 + 1	256	256	Y	Y	Y	Y	Y	Y	I ² C, Fm+	125	Y	31.5 kHz	122 Hz	In production
PCA9956B	RGB Color Mixing	24	3.0 V–5.5 V	100 μ A	Constant current	57 mA	20 V	Open drain (Sink)	N	24 + 1	256	256	Y	Y	Y	Y	Y	Y	I ² C, Fm+	125	Y	31.5 kHz	122 Hz	In production
PCA9957	RGB Color Mixing	24	2.7 V–5.5 V	170 μ A	Constant current	32 mA	5.5 V	Open drain (Sink)	N	24 + 1	256	256	Y	Y	Y	Y	Y	Y	SPI 10 MHz	Daisy-Chain	Y	31.25 kHz	122 Hz	In production
PCA9958 ⁽³⁾	RGB Color Mixing	24	2.7 V–5.5 V	170 μ A	Constant current	63 mA	5.5 V	Open drain (Sink)	N	24 + 1	256	256	Y	Y	Y	Y	Y	Y	SPI 10 MHz	Daisy-Chain	Y	31.25 kHz	122 Hz	In development
PCA9959	RGB Color Mixing - 64 Grid preset	24	2.7 V–5.5 V	170 μ A	Constant current	63 mA	5.5 V	Open drain (Sink)	N	N	N	N	Y	Y	Y	Y	Y	Y	SPI 10 MHz	Daisy-Chain	Y	N	N	In production

⁽¹⁾ Typical value measured with $V_{DD} = 5.5$ V, no load, $V_I = V_{DD}$ or V_{SS} and FSCL = 0 Hz

⁽²⁾ External clock input option

⁽³⁾ Commercial and AEC-Q100 compliant version

⁽⁴⁾ AEC-Q100 compliant version only

Please visit www.nxp.com/LEDDrivers for more details.

PCA9635 VOLTAGE-SWITCH LED CONTROLLER APPLICATION EXAMPLE

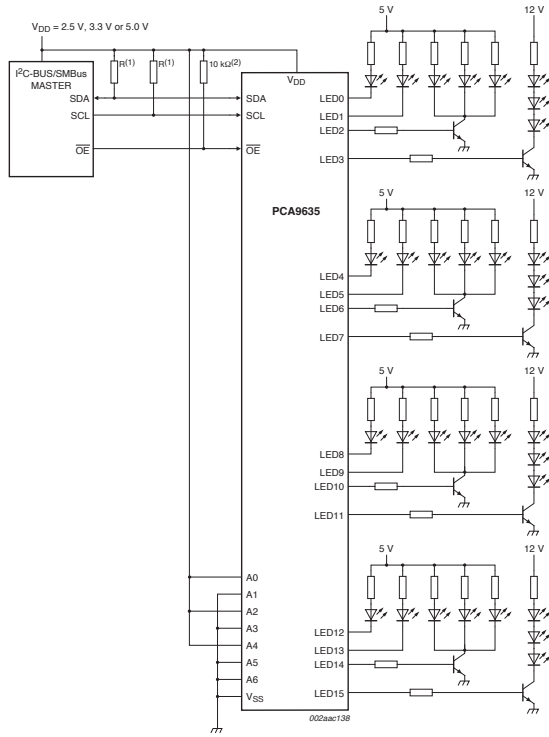

PCA9955B CONSTANT CURRENT LED DRIVER APPLICATION EXAMPLE

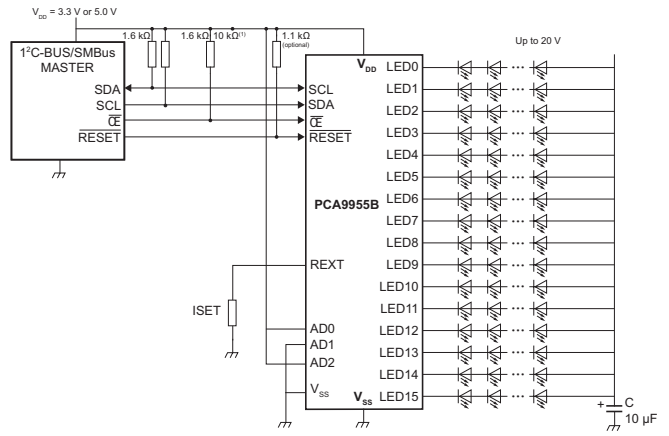

ARCHITECTURAL LIGHTING



AUTOMOTIVE INSTRUMENT CLUSTER



CAR INTERIOR LED APPLICATION EXAMPLE



CAR RADIO BACKLIGHT



APPLICATION SUPPORT

For added application support, NXP offers the following application reports on the LED driver family devices:

Description	Title	Applicable Devices	Type	Document Date
Driving LED Light Bars Using NXP Solutions	AN10579_1	All LEDs	App note	Feb-1-07
I ² C Devices for LED Display Control	AN264_1	PCA9530/1/2/3 PCA9550/1/2/3	App note	Jul-22-02
PCA9632 1.8 V I ² C-bus and 2.8 V V _{DD} Operation	AN11169	PCA9632	App note	Mar-26-12
A Guide to Designing for ESD and EMC	AN10897	All LEDs	App note	Jan-19-10
PCA9955 Demonstration Board OM13330	UM10572	PCA9955	User guide	Jun-7-12
PCA9956B Demonstration Board OM13321	UM10709	PCA9956B	User guide	Aug-11-17
PCA9955B Demonstration Board OM13483	UM10729-1	PCA9955	User guide	Aug-1-17
PCA9532 Demonstration Board OM13528	UM10988	PCA9530/31/32/33 PCA9550/51/52/53	User guide	May-2-16
PCA9632 Demonstration Board OM13269	UM10528	PCA9632	User guide	Jan-30-12
PCA9745B Demonstration Board OM13524	UM11009	PCA9745B	User guide	Jun-27-16
Gaming Suitcase Demo System	UM10563	LED and stepper motor	User guide	Aug-9-12
PCA9957 Demonstration Board OMPCA9957LEDEV	UM11196	PCA9957	User guide	Apr-27-20
PCA9959 Demonstration Board OMPCA9959LEDEV	UM11436	PCA9959	User guide	Apr-27-20

For more information, visit <http://www.nxp.com/LEDDrivers>.

NXP offers evaluation modules and demo boards that can be used to develop software and evaluate the performance of the LED drivers. Here is the list of the boards and some examples.

Order Board Number	Description
PCA9955BTW-ARD	PCA9955B Arduino Board
PCA9957HN-ARD	PCA9957 Arduino Board
PCA9958HN-ARD	PCA9958 Arduino Board
PCA9959HN-ARD	PCA9959 Arduino Board
OM13321	PCA9956B LED EVB
OM13528	PCA9532BS LED EVB
OM13329	PCA9952 LED EVB
OM13330	PCA9955 LED EVB

Order Board Number	Description
OM13269	PCA9632 LED EVB
OM13327	PCA9634 LED EVB
OM13333	PCA9635 LED EVB
OM13332	PCA9685 LED EVB
OM13524	PCA9745B LED SPI EVB
OM13483	PCA9955B LED EVB
OMPCA9957LEDEV	PCA9957 24-CHANNEL LED DEMO BOARD
OMPCA9959LEDEV	PCA9959 24-CHANNEL LED DEMO BOARD

OM13483—PCA9955B 16-CHANNEL LED DEMO BOARD

The OM13483 board is an add-on to the 9-pin connector of NXP's Fm+ I²C Bus development board. This daughter board makes it easy to test and design with the PCA9955B, a 16-channel Fast-mode Plus (Fm+) 57 mA constant current LED driver for LED strings up to 20 V.

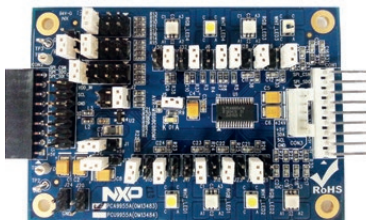

OM13321—PCA9956B 24-CHANNEL LED DEMO BOARD

The OM13321 board is an add-on to the 9-pin connector of NXP's Fm+ I²C Bus development board. This daughter board makes it easy to test and design with the PCA9956B, a 24-channel Fast-mode Plus (Fm+) 57 mA constant current LED driver for LED strings up to 20 V.

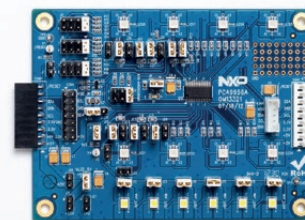

OMPCA9957LEDEV—PCA9957 24-CHANNEL LED DEMO BOARD

The OMPCA9957LEDEV board is an add-on to Arduino® shield connector of NXP's OM13089 MCU board. This daughter board makes it easy to test and design with the PCA9957, a 24-channel SPI interface and 32-mA constant current LED driver. Outputs allow up to 5.5 V for LED supply.

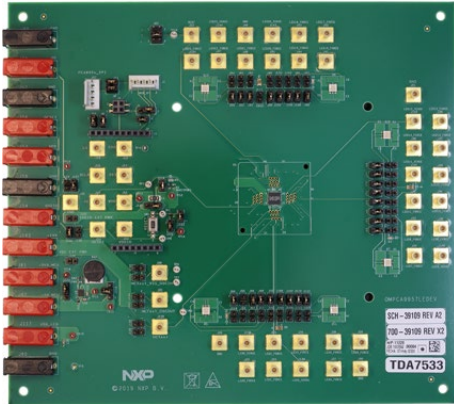

OMPCA9959LEDEV—PCA9959 24-CHANNEL LED DEMO BOARD

The OMPCA9959LEDEV board is an add-on to Arduino shield connector of NXP's OM13089 MCU board. This daughter board makes it easy to test and design with the PCA9959, a 24-channel SPI interface and 63-mA constant current LED driver. Outputs allow up to 5.5 V for LED supply.

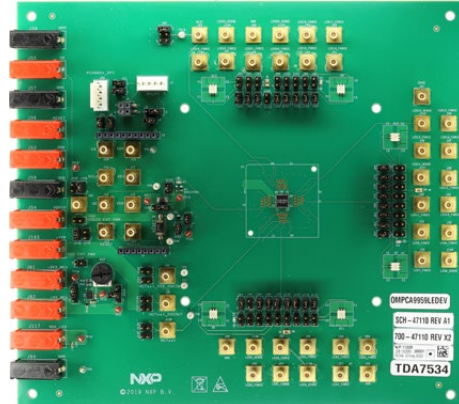

PCA9957HN-ARD ARDUINO SHIELD BOARD

The PCA9957HN-ARD Arduino Shield allows easy integration with Arduino EVKs to evaluate the LED driver features for color mixing, blinking and dimming LEDs. A graphical interface allows the user to easily explore the different functions of the driver to create an evaluation system.

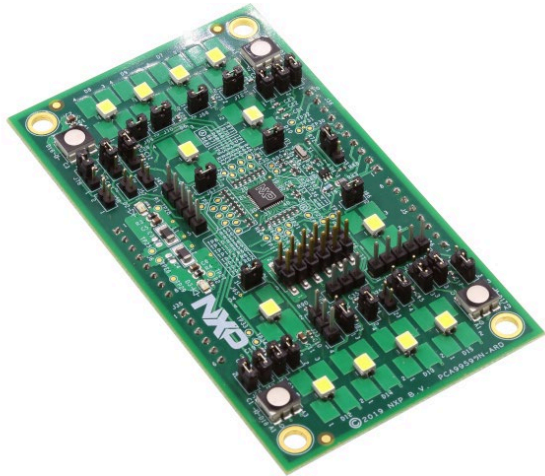

PCA9959HN-ARD ARDUINO SHIELD BOARD

The PCA9959HN-ARD Arduino Shield allows easy integration with Arduino EVKs to evaluate the LED driver features for color mixing, blinking and dimming LEDs. A graphical interface allows the user to easily explore the different functions of the driver to create an evaluation system.

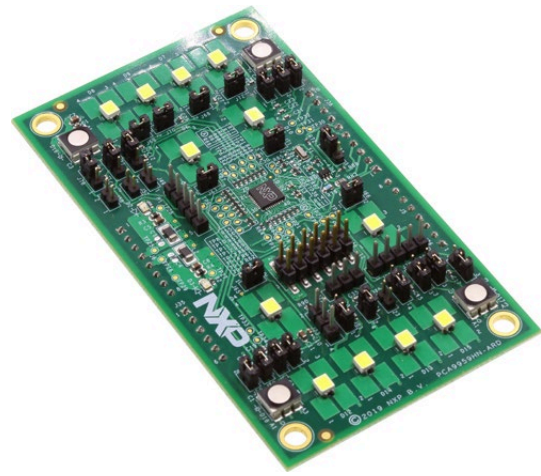

For current information about NXP products and documentation, please visit www.nxp.com//LEDDrivers.

NXP and the NXP logo are trademarks of NXP B.V. All other product or service names are the property of their respective owners.
© 2022 NXP B.V.

Document Number: 939775017588 REV 3