



2.4/5 GHz Dual-Band 2x2 Wi-Fi® 6 (802.11ax) + Bluetooth® 5.3 Automotive Solution

88Q9098

Last Updated: Mar 26, 2024

The 88Q9098 family of automotive wireless SoCs is the industry's first Wi-Fi 6 solution based on the latest IEEE 802.11ax standards supporting 2x2 plus 2x2 concurrent dual Wi-Fi and dual-mode Bluetooth 5.3. Delivering reliable and high-performance wireless connectivity is becoming more difficult in the increasingly congested automobile environment. The new 88Q9098 combo solution enables gigabit-level performance, superior reliability, and enhanced security for the car and extends leadership in providing comprehensive Wi-Fi 6 solutions. Our innovative concurrent dual Wi-Fi architecture sets a new technology precedent, integrating two complete Wi-Fi subsystems into a single SoC, and enabling two independent 2x2 data streams to run concurrently and at full throughput.

The 88Q9098 family of footprint compatible wireless solutions include:

- 88Q9098 - 2x2 + 2x2 Concurrent Dual Wi-Fi with Bluetooth 5 (AEC-Q100 grade 3)
- 88Q9098S - 2x2 + 2x2 Concurrent Dual Wi-Fi with Bluetooth 5 (AEC-Q100 grade 2)

Wireless modules based on the NXP 88Q9098 are offered by leading [module manufacturers](#).

88Q9098 SoC Application Block Diagram (Internal PA/LNA/SW) Block Diagram

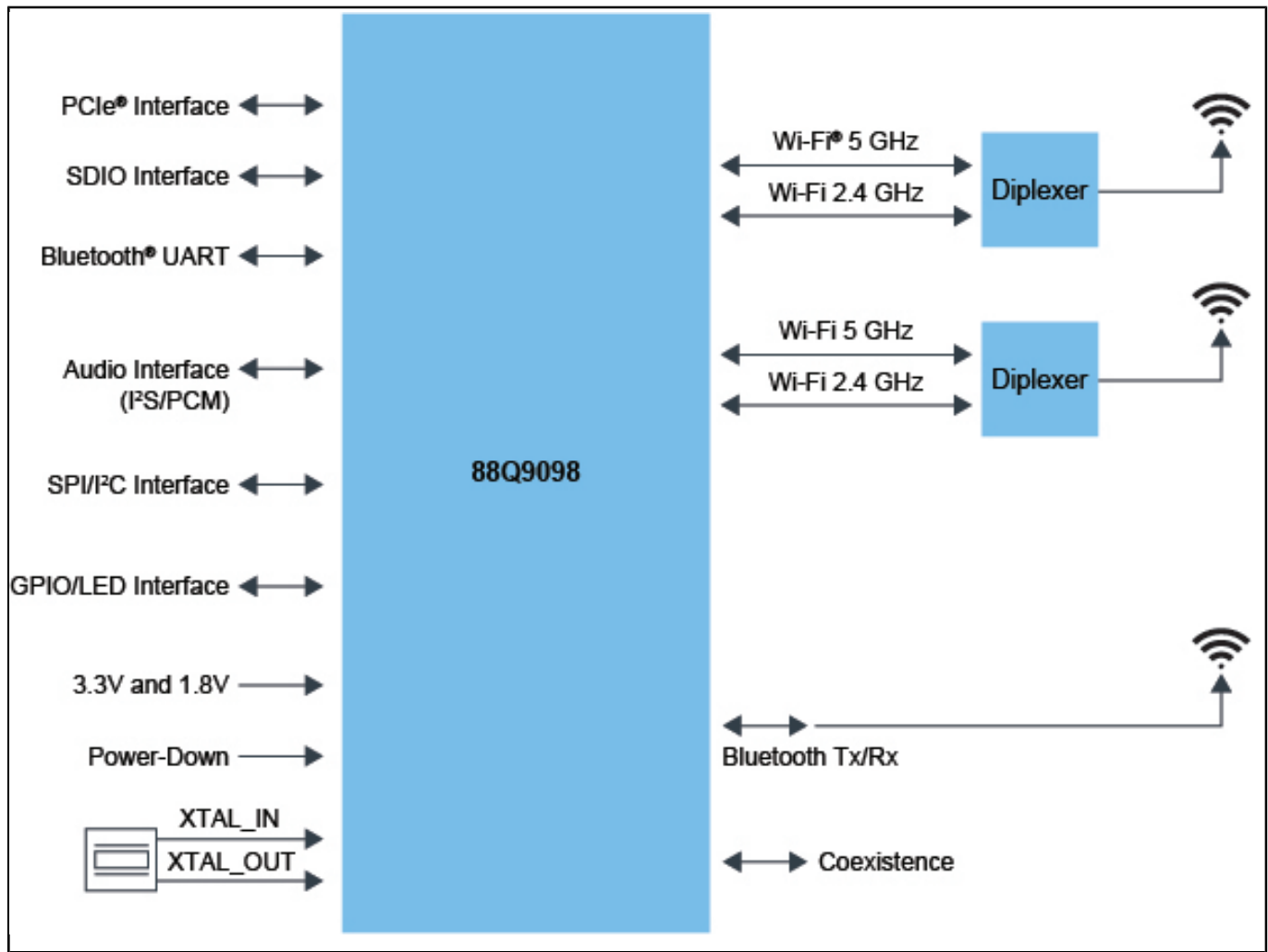

88Q9098 SoC Internal Block Diagram Block Diagram

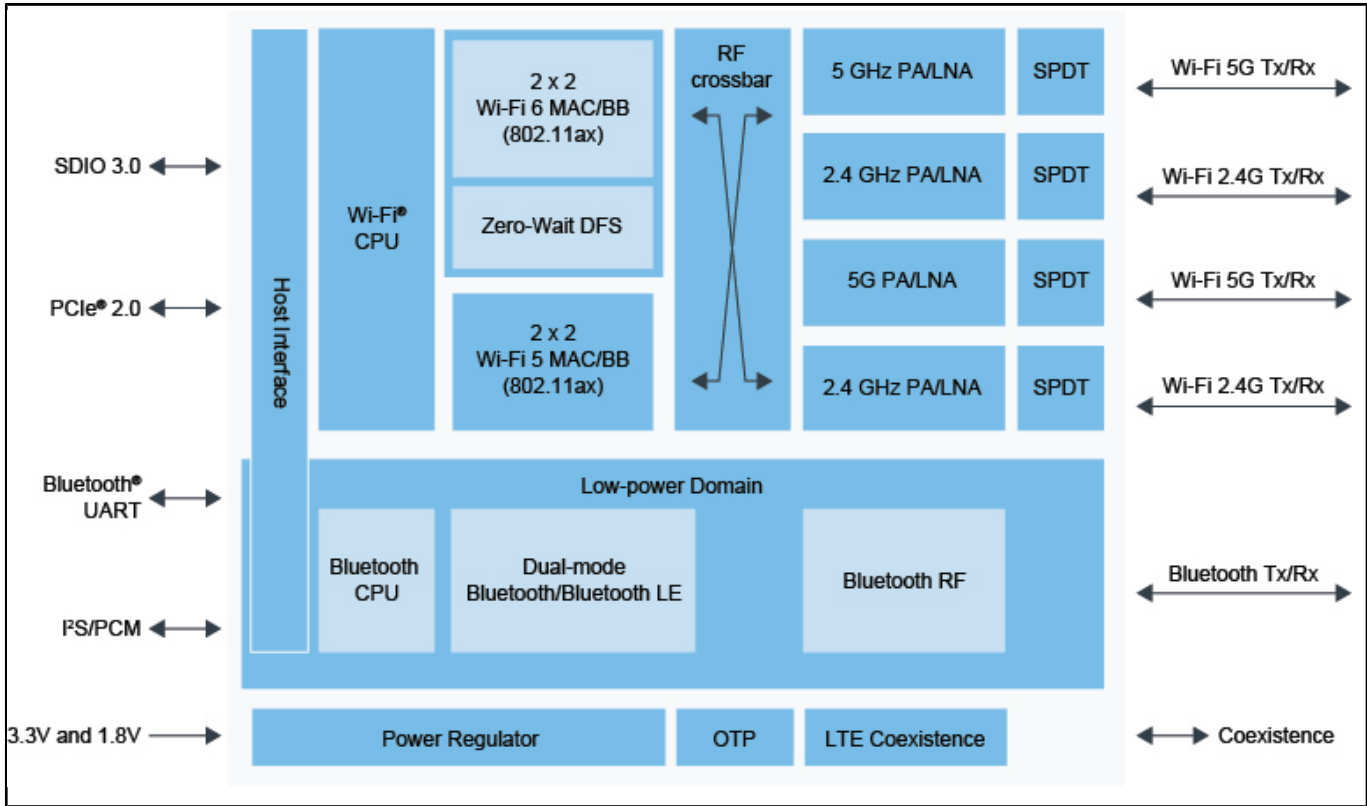

View additional information for [2.4/5 GHz Dual-Band 2x2 Wi-Fi® 6 \(802.11ax\) + Bluetooth® 5.3 Automotive Solution](#).

Note: The information on this document is subject to change without notice.

www.nxp.com

NXP and the NXP logo are trademarks of NXP B.V. All other product or service names are the property of their respective owners. The related technology may be protected by any or all of patents, copyrights, designs and trade secrets. All rights reserved. © 2024 NXP B.V.