



Wi-Fi® 6 1x1 Concurrent Dual Wi-Fi (CDW) and Bluetooth® 5.3 Combo SoC

AW690

Last Updated: Oct 9, 2024

The AW690 is a highly integrated Wi-Fi 6 device enabling concurrent dual Wi-Fi (CDW) and Bluetooth 5.3 operation. Supporting a 1x1 CDW configuration in both the 2.4 GHz and 5 GHz bands, and 2x2 MIMO single-band operation, the system-on-chip (SoC) provides a peak data rate of 1.2#Gbit/s and implements advanced features including MU-MIMO, OFDMA and target wake time (TWT).

With integrated 2.4#GHz and 5#GHz TX power amplifiers (PA), RX low noise amplifiers (LNA) and Tx/Rx switches (T/R SW) as well as a full Bluetooth radio, the AW690 simplifies the design and minimizes the PCB area.

The AW690 implements advanced Wi-Fi and Bluetooth coexistence hardware with algorithms to optimize collaborative performance. In addition, support for external radio coexistence (for example, cellular) is provided through an external interface.

With AEC-Q100 Grade 3- compliant options, the AW690 provides multiple host interface options for the Wi-Fi radios (PCIe) and Bluetooth radio (UART) to provide a flexible design for easy integration into demanding automotive applications.

Wireless modules based on the NXP AW690 are offered by leading [module manufacturers](#).

Application block diagram (internal PA/LNA/SW) Block Diagram

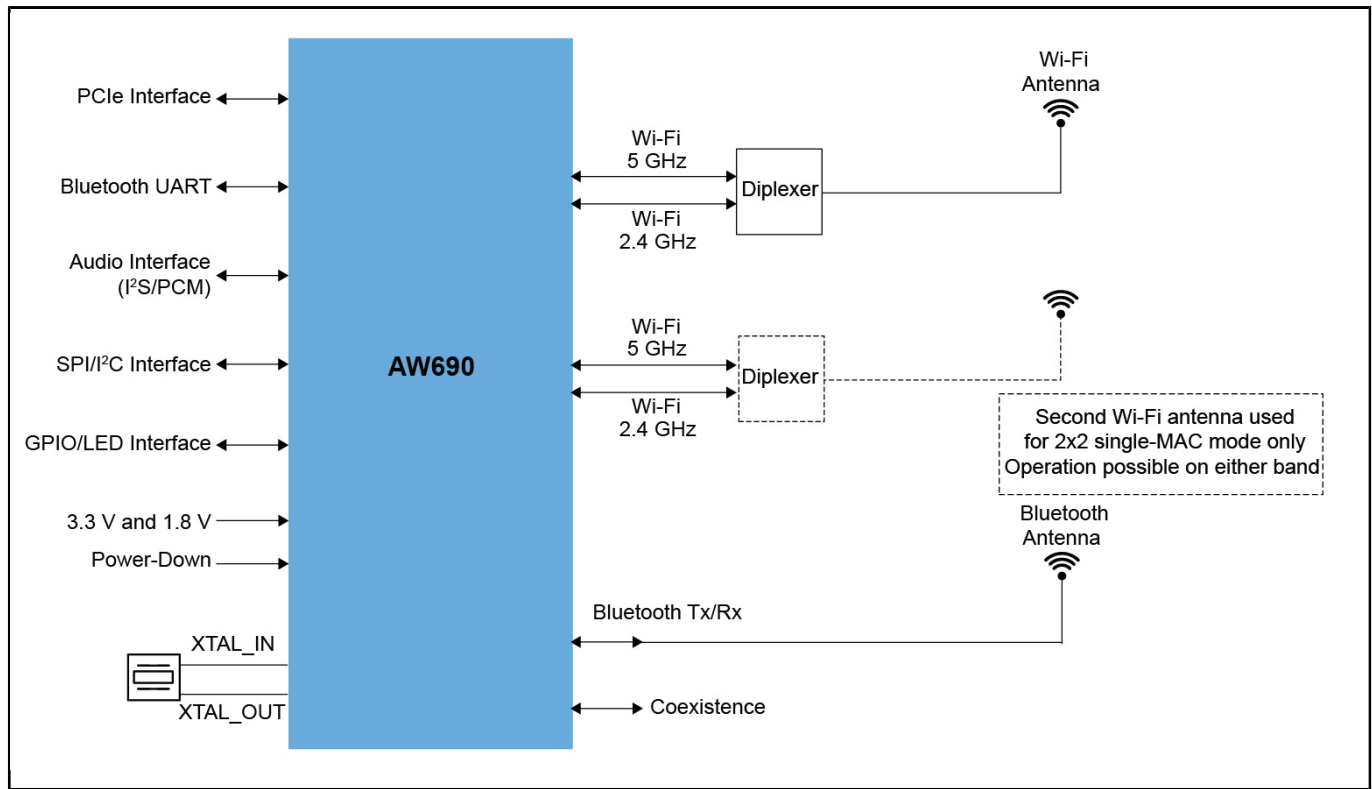

Application block diagram (FEM) Block Diagram

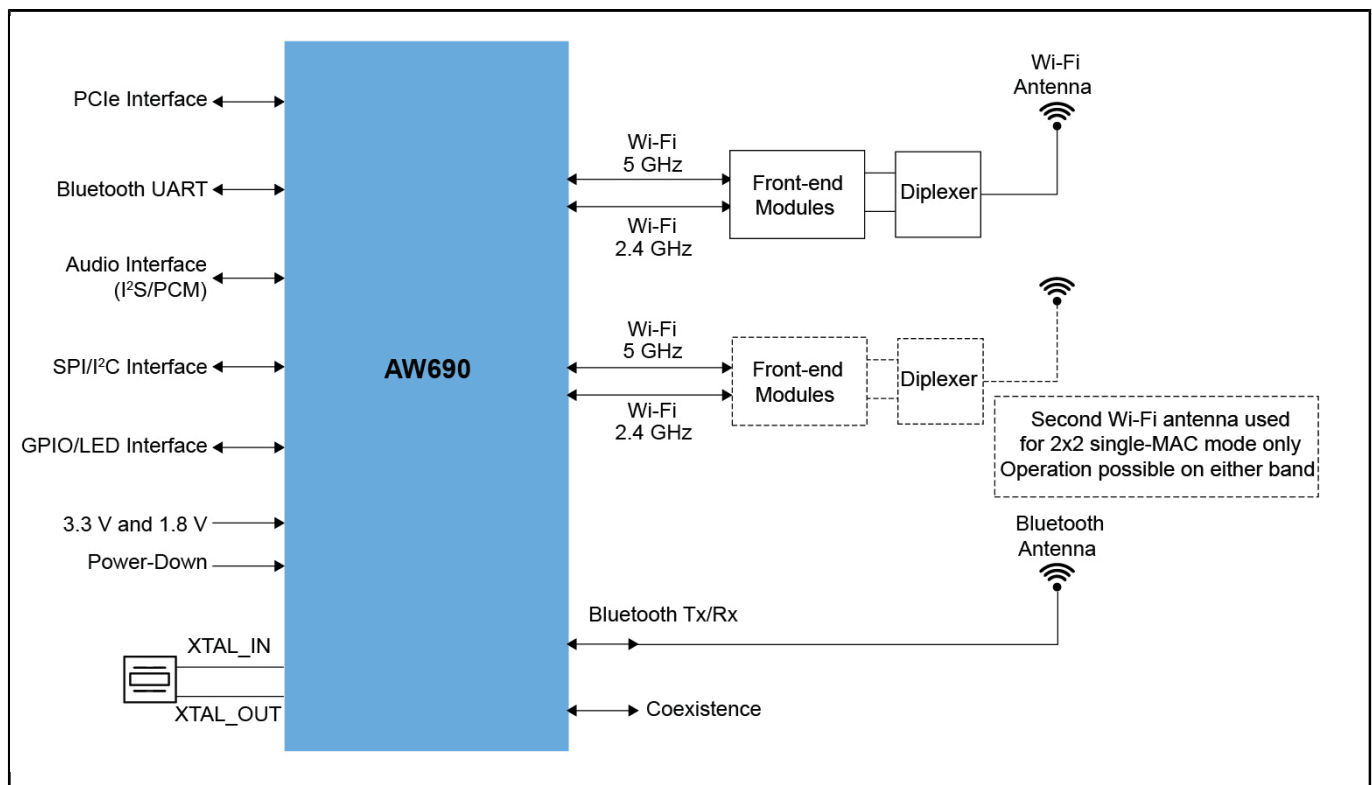

Internal Block Diagram - 1x1 Concurrent Dual-Wireless Mode Block Diagram

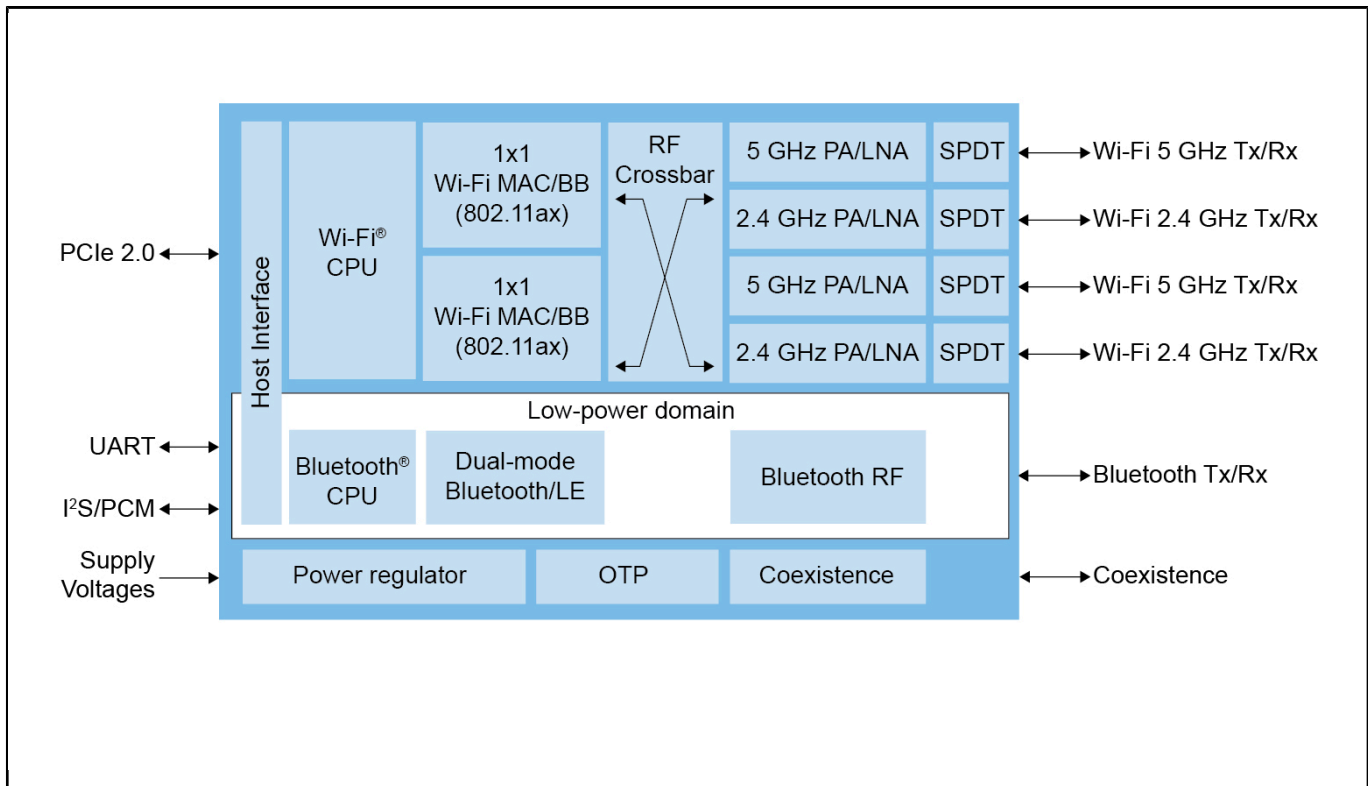

Internal Block Diagram - 2x2 Single-MAC Mode Block Diagram

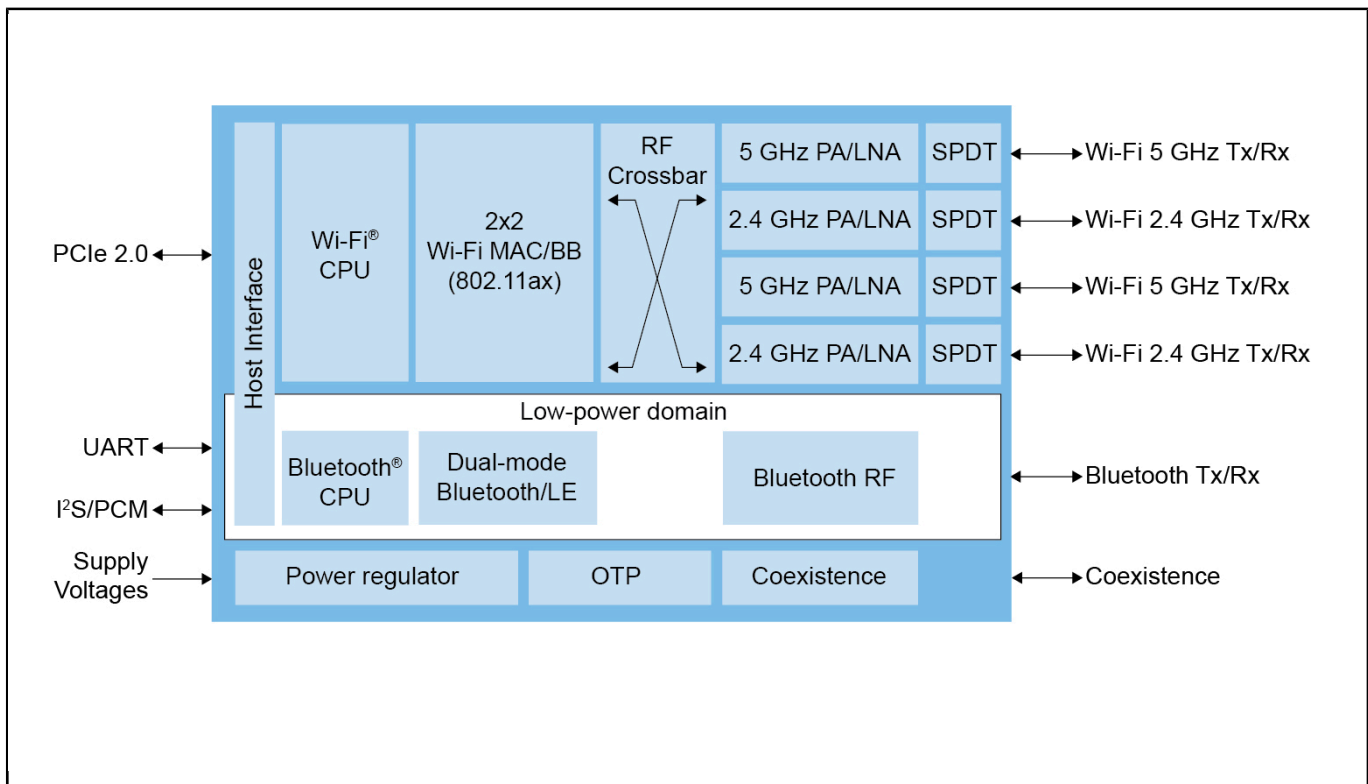

Note: The information on this document is subject to change without notice.

www.nxp.com

NXP and the NXP logo are trademarks of NXP B.V. All other product or service names are the property of their respective owners. The related technology may be protected by any or all of patents, copyrights, designs and trade secrets. All rights reserved. © 2024 NXP B.V.