



18 Channel Li-Ion Battery Cell Controller IC ASIL D with EIS

BMA7418 NEW

Active

Last Updated: Mar 10, 2026

BMA7418 is an automotive lithium-ion (Li-ion) battery cell controller-integrated circuit (IC) with a dedicated, high-accuracy analog-to-digital converter (ADC) per voltage measurement channel. Electrochemical impedance spectroscopy (EIS) is supported by a high synchronization capability and integrated Discrete Fourier Transform (DFT) per measurement channel. With BMA7118 and BMA7418 in the same product family—having pin compatibility and using the same software—the two are interchangeable. BMA7418 offers low 5 mA current consumption due to its integrated DC-to-DC converter. As a fully redundant and independent internal architecture, it achieves automotive safety integrity level ASIL D functional safety.

BMA7418 Block Diagram

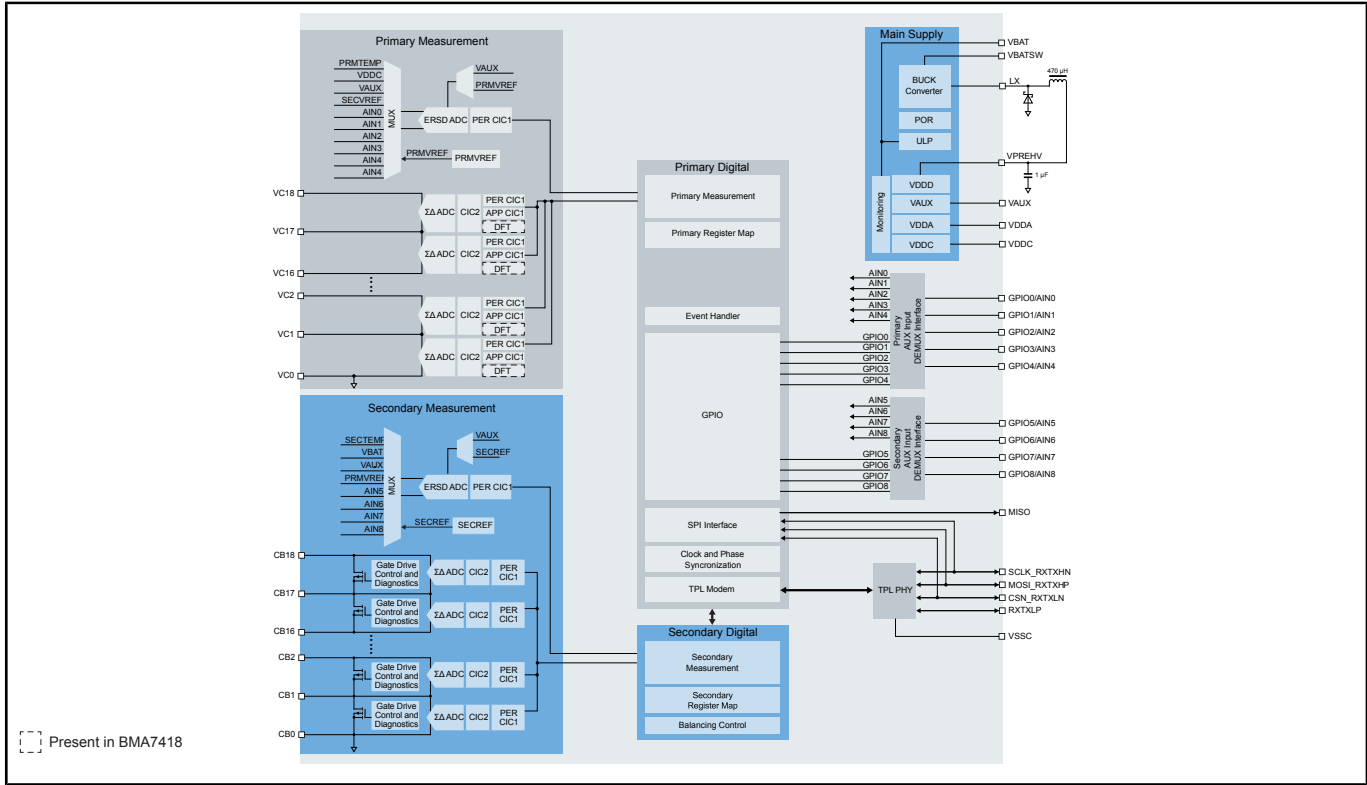

View additional information for [18 Channel Li-Ion Battery Cell Controller IC ASIL D with EIS](#).

Note: The information on this document is subject to change without notice.

www.nxp.com

NXP and the NXP logo are trademarks of NXP B.V. All other product or service names are the property of their respective owners. The related technology may be protected by any or all of patents, copyrights, designs and trade secrets. All rights reserved. © 2026 NXP B.V.