



KV Series 3-Phase Brushless DC Motor Control Reference Design

BRUSHLESS-DC-MOTOR-CONTROL

Last Updated: Jun 8, 2023

The 3-phase brushless DC (BLDC) motor control reference design is based on V series MCUs and intended and provides an example for 3-phase sensorless BLDC motor control solutions. The reference design uses a six-step communication process, including closed-loop speed control and dynamic motor current limitation. The comprehensive analog integration provides a high-performance solution for BLDC motor control applications.

3-Phase Brushless DC Motor Block Diagram

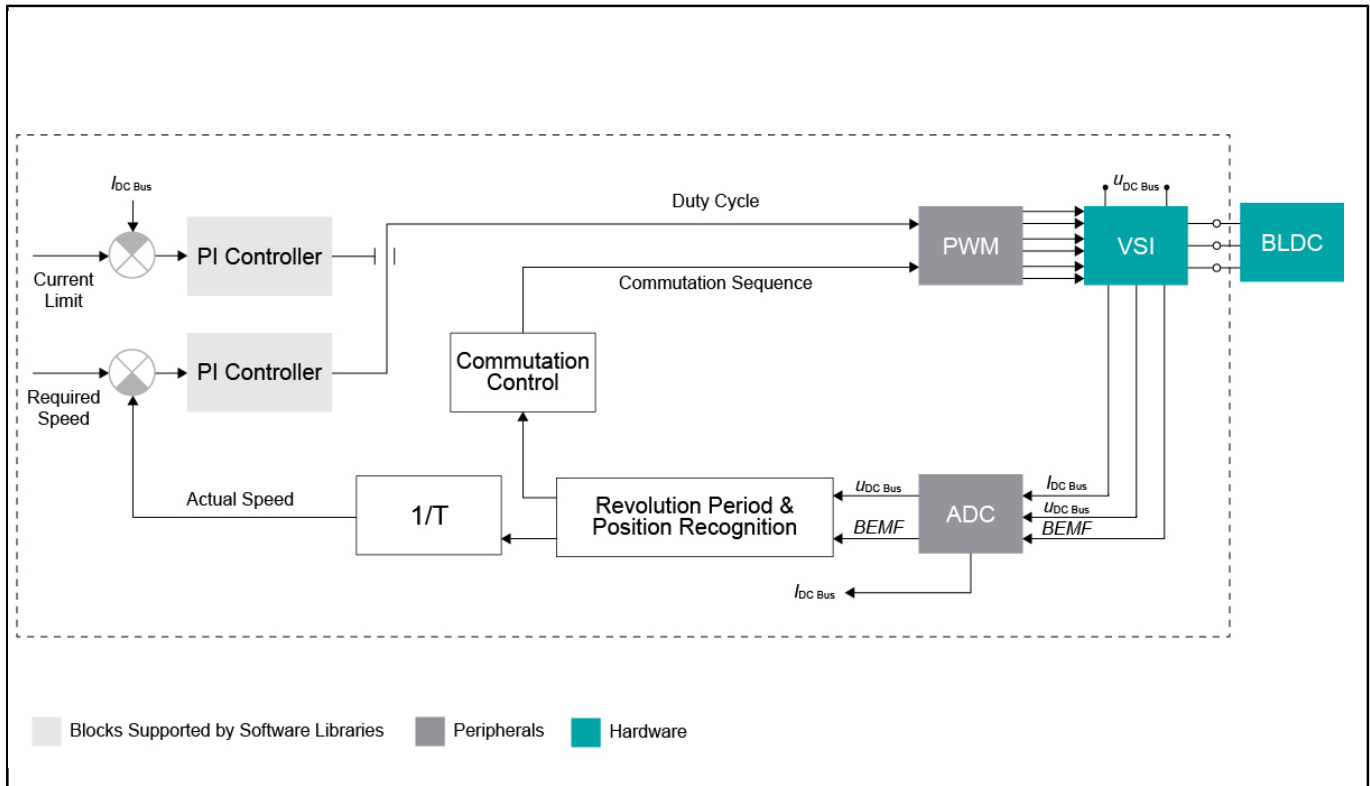

View additional information for [KV Series 3-Phase Brushless DC Motor Control Reference Design](#).

Note: The information on this document is subject to change without notice.

www.nxp.com

NXP and the NXP logo are trademarks of NXP B.V. All other product or service names are the property of their respective owners. The related technology may be protected by any or all of patents, copyrights, designs and trade secrets. All rights reserved. © 2024 NXP B.V.