



Second Generation High-Performance General Purpose Switch

CBTL06GP213EE

Last Updated: Apr 8, 2022

The CBTL06GP213 is a six-channel ('hex') multiplexer for DisplayPort, HDMI and PCI Express applications at Generation 2 ('Gen2') speeds. It provides four differential channels capable of 1 : 2 switching or 2 : 1 multiplexing bidirectional, AC#coupled PCI Express, DisplayPort signals, USB3 SuperSpeed or DC coupled TMDS signals, using high#bandwidth pass#gate technology. It provides support for high common#mode/bias voltage on the high#speed differential channels. Additionally, it provides for switching/multiplexing of the Hot Plug Detect signal as well as the AUX or DDC (Display Data Channel) signals, for a total of six channels on the display side. The AUX and DDC channels provide a four-position multiplexer such that an additional level of multiplexing can be accomplished when AUX and DDC I/Os are on separate pins of the display source device.

The CBTL06GP213 is designed for Gen2 speeds, supporting 5.0 Gbit/s for PCI Express, 5.4 Gbit/s for DisplayPort or 6 Gbit/s for HDMI 2.0. It consumes 490 μ A current (typical) in operational mode and provides a shutdown function to support battery-powered applications.

typical application of CBTL06GP213 is on applications where one of two GPU display sources must be selected to connect to a display sink device or connector. A controller chip selects which path to use by setting a select signal HIGH or LOW. Due to the non-directional nature of the signal paths (which use high-bandwidth pass gate technology), the CBTL06GP213 can also be used in the reverse topology, for example, to connect one display source device to one of two display sink devices or connectors.

CBTL06GP213 Block Diagram Block Diagram

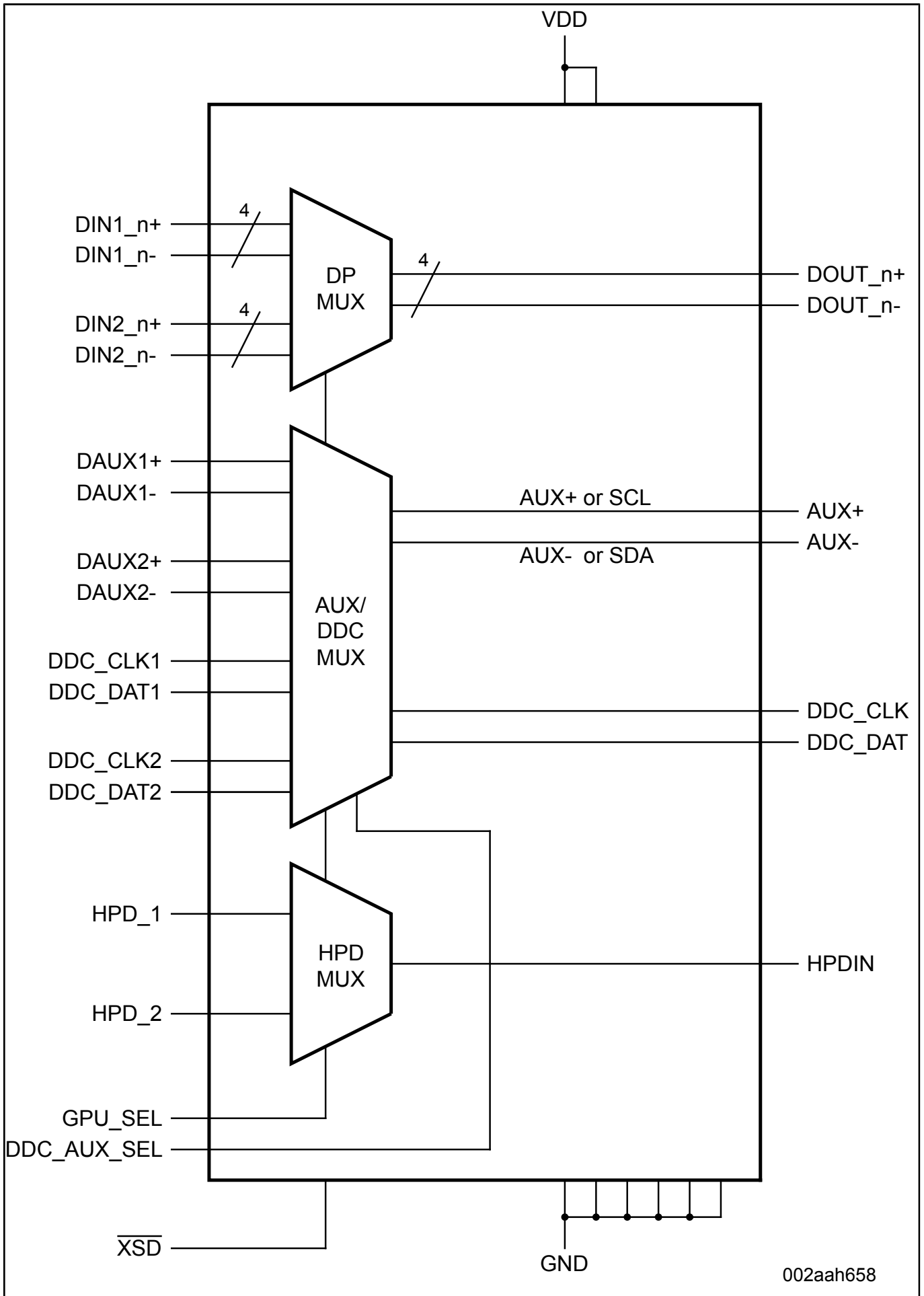

View additional information for [Second Generation High-Performance General Purpose Switch](#).

Note: The information on this document is subject to change without notice.

www.nxp.com

NXP and the NXP logo are trademarks of NXP B.V. All other product or service names are the property of their respective owners. The related technology may be protected by any or all of patents, copyrights, designs and trade secrets. All rights reserved. © 2022 NXP B.V.