



# eScooter NFC Access and Battery

## ESCOOTNFCBTY

Last Updated: Sep 9, 2024

Contactless technology is utilized for a variety of government-identification applications, from ID cards to e-passports. At NXP, security for government applications is a vital part of what we do as a company. We focus on creating more effective ways to protect confidential data and keep private information safe from harm. This solution, based on i.MX RT technology and our NFC portfolio products, will cover a wide range of uses for identification and vehicular applications.

# eScooter NFC Access and Battery Block Diagram

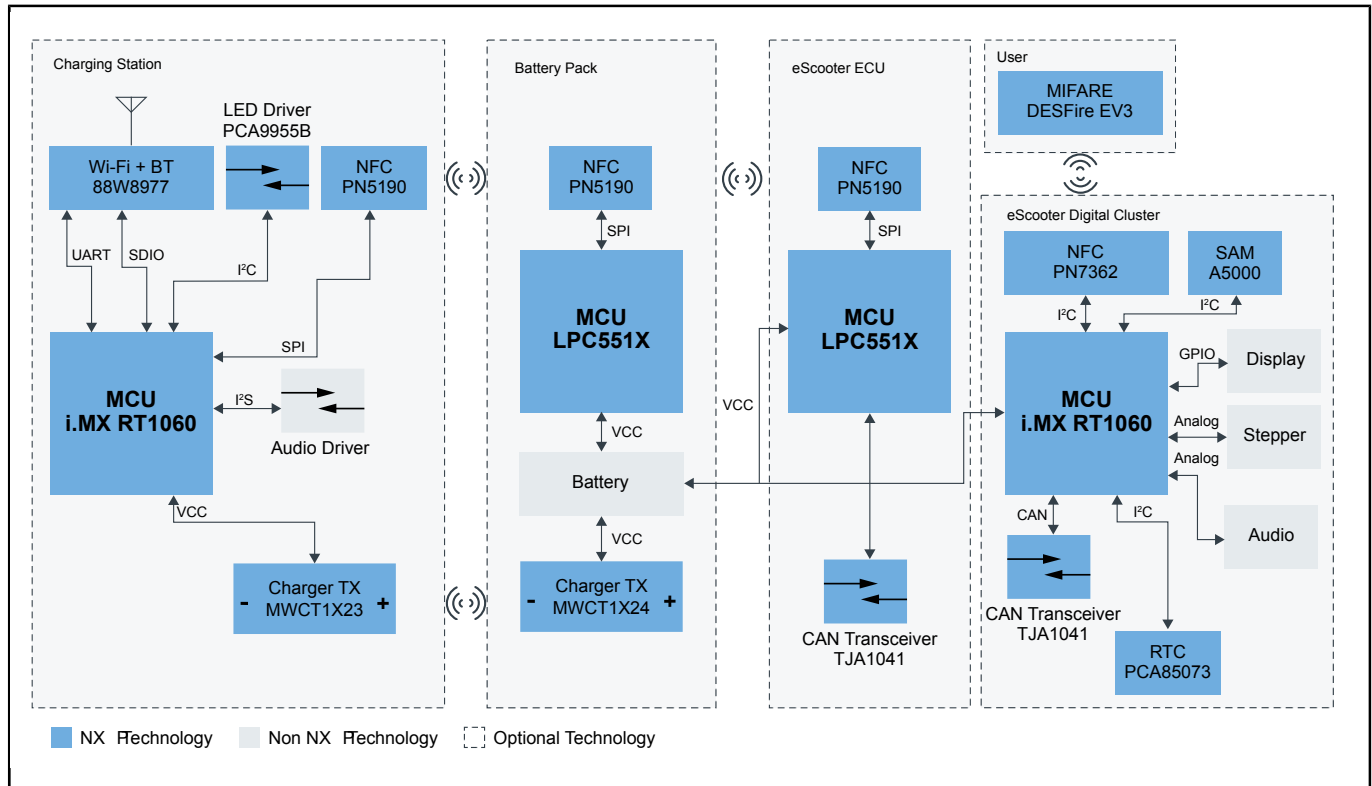

View additional information for [eScooter NFC Access and Battery](#).

**Note:** The information on this document is subject to change without notice.

**www.nxp.com**

NXP and the NXP logo are trademarks of NXP B.V. All other product or service names are the property of their respective owners. The related technology may be protected by any or all of patents, copyrights, designs and trade secrets. All rights reserved. © 2024 NXP B.V.