



# Safety System Basis Chip for S32 Microcontrollers, Fit for ASIL B

## FS84

Last Updated: Dec 17, 2024

The FS84 is an automotive, functionally safe multi-output power supply integrated circuit. It's focused on ADAS sensor (camera, radar, Lidar) applications and is the primary companion chip of the S32 microcontroller.

The FS84 includes multiple switch mode and linear voltage regulators, enhanced safety features with fail-safe outputs. This makes it a full part of a safety-oriented system up to ASIL B safety integrity level.

It is part of a complete family of devices offering scalability in power and safety FS84 and FS85, pin to pin and software compatible. It is developed in compliance with the ISO 26262 standard and is qualified according to AEC-Q100 requirements.

## FS8400, Safety SBC Block diagram Block Diagram

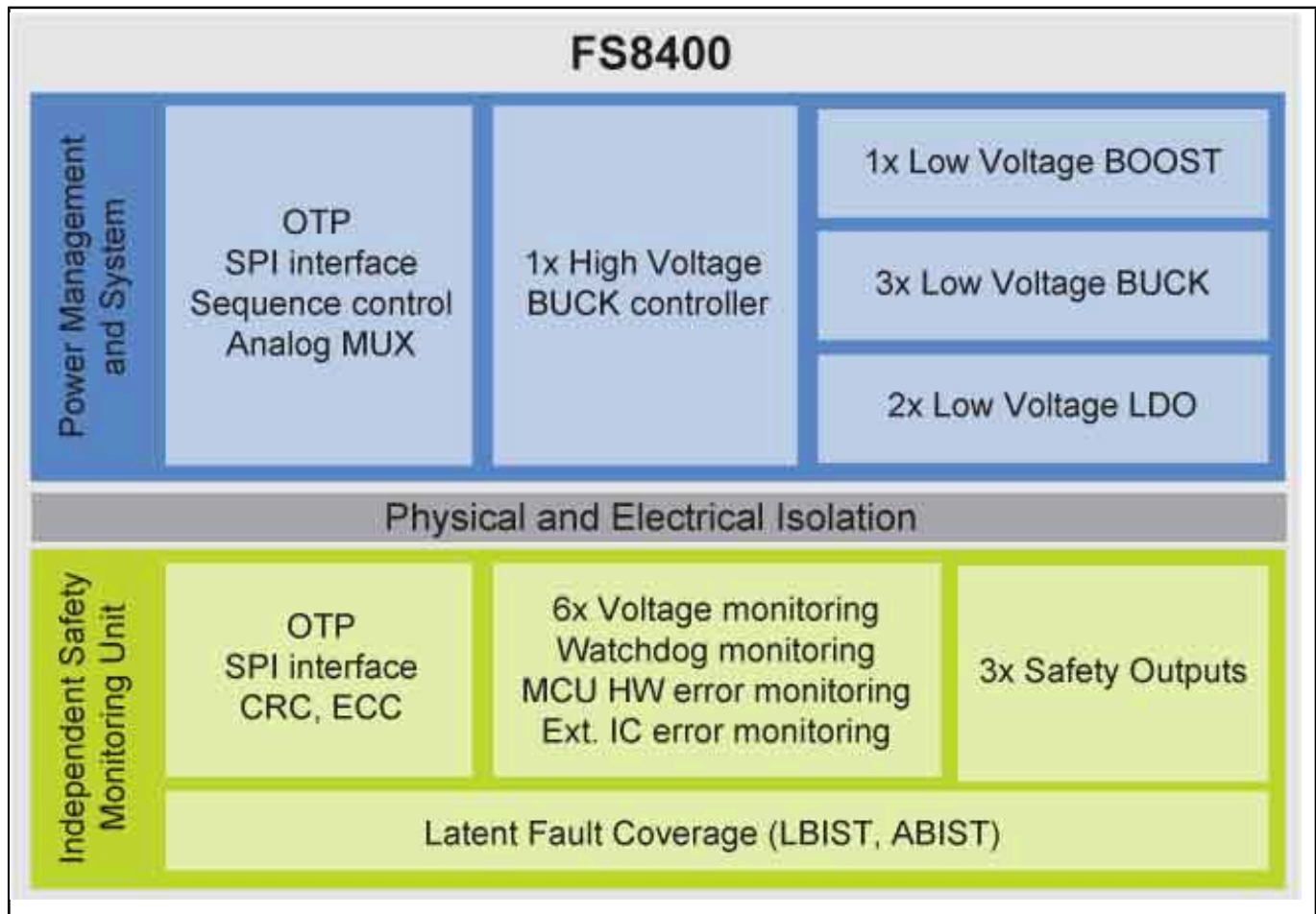

View additional information for [Safety System Basis Chip for S32 Microcontrollers, Fit for ASIL B](#).

Note: The information on this document is subject to change without notice.

[www.nxp.com](http://www.nxp.com)

NXP and the NXP logo are trademarks of NXP B.V. All other product or service names are the property of their respective owners. The related technology may be protected by any or all of patents, copyrights, designs and trade secrets. All rights reserved. © 2025 NXP B.V.