



3-Phase Brushless Motor Pre-Driver

GD3000

Last Updated: Aug 12, 2022

The GD3000 is a gate driver IC for three-phase motor drive applications providing three half-bridge drivers, each capable of driving two N-channel MOSFETs.

- Supports 1 A to 2.5 A peak current capability
- Can operate off of a single power supply with a wide range from 6 V to 60 V with 75 V transient protection
- Uses a bootstrap gate driver architecture with trickle charge circuitry to support 100% duty cycle
- Uses programmable cross-talk protection when the high-side or low-side MOSFET is switching to prevent flow of current
- Integrated VDS sensing of the high-side and low-side MOSFETs is used to protect the external power stage against over-current conditions
- Includes a current shunt amplifier for accurate current measurement for phase error detection

The IC interfaces to a MCU via six direct input control signals, a SPI port for device setup and asynchronous reset, enable and interrupt signals. Both 5.0 and 3.0 V logic level inputs are accepted and 5.0 V logic level outputs are provided.

GD3000 Block Diagram Block Diagram

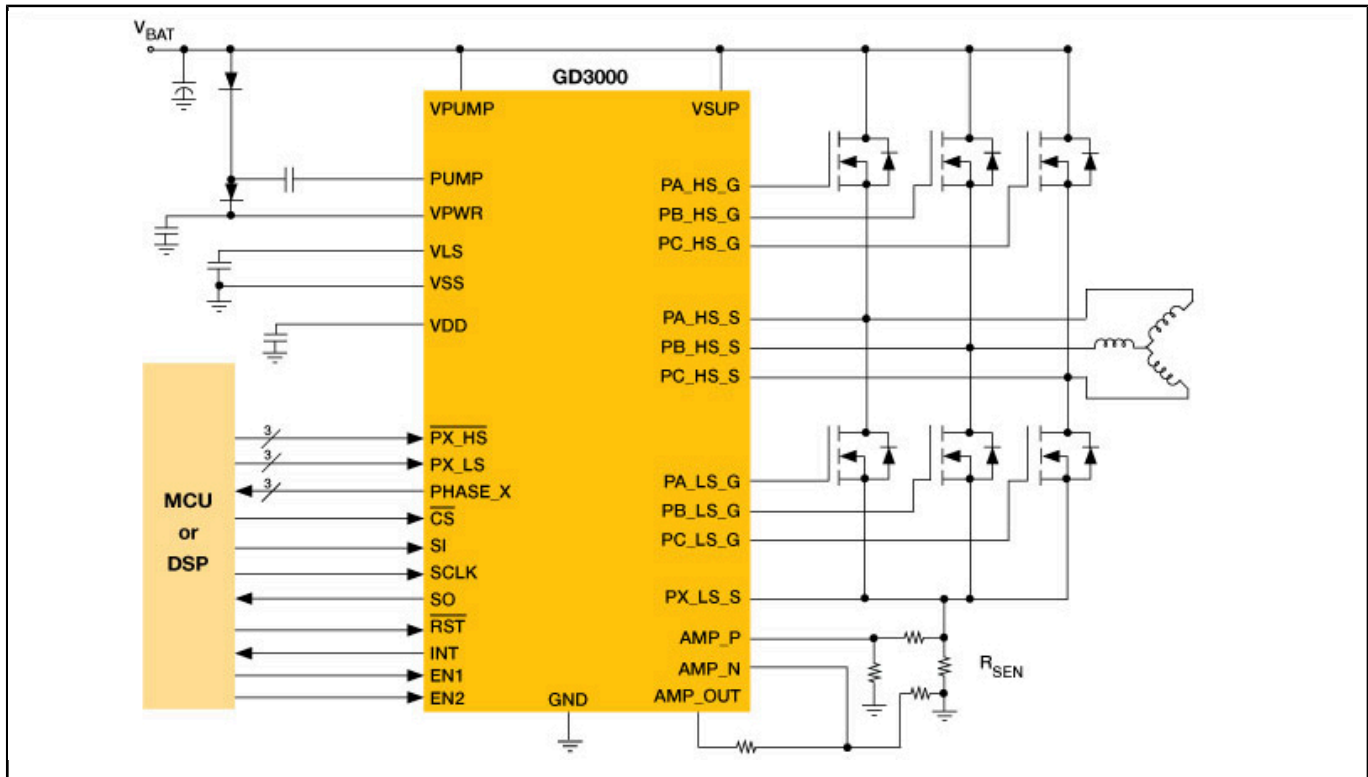

View additional information for [3-Phase Brushless Motor Pre-Driver](#).

Note: The information on this document is subject to change without notice.

www.nxp.com

NXP and the NXP logo are trademarks of NXP B.V. All other product or service names are the property of their respective owners. The related technology may be protected by any or all of patents, copyrights, designs and trade secrets. All rights reserved. © 2022 NXP B.V.