



ZigBee and IEEE802.15.4 Wireless Microcontroller with 512 KB Flash, 32 KB RAM

JN5169

Last Updated: Apr 8, 2022

Note: [JN5189/88T](#) is preferred for any new new Zigbee®, Thread design. No new software releases planned.

The JN5169 is an ultra low power, high performance wireless microcontroller suitable for ZigBee applications. It features 512 kB embedded Flash, 32 kB RAM and 4 kB EEPROM memory, allowing OTA upgrade capability without external memory. The 32-bit RISC processor offers high coding efficiency through variable width instructions, a multi-stage instruction pipeline and low-power operation with programmable clock speeds. It also includes a 2.4 GHz IEEE802.15.4 compliant transceiver and a comprehensive mix of analog and digital peripherals. The very low RX operating current (down to 13 mA and with a 0.7 μ A sleep timer mode) gives excellent battery life allowing operation direct from a coin cell.

The peripherals support a wide range of applications. They include a 2-wire compatible I²C-bus and SPI-bus which can operate as either leader or follower, a 6-channel ADC with a battery monitor and a temperature sensor. It can support a large switch matrix of up to 100 elements, or alternatively a 40-key capacitive touch pad.

For support documentation, please click [here](#).

JN5169 Block Diagram Block Diagram

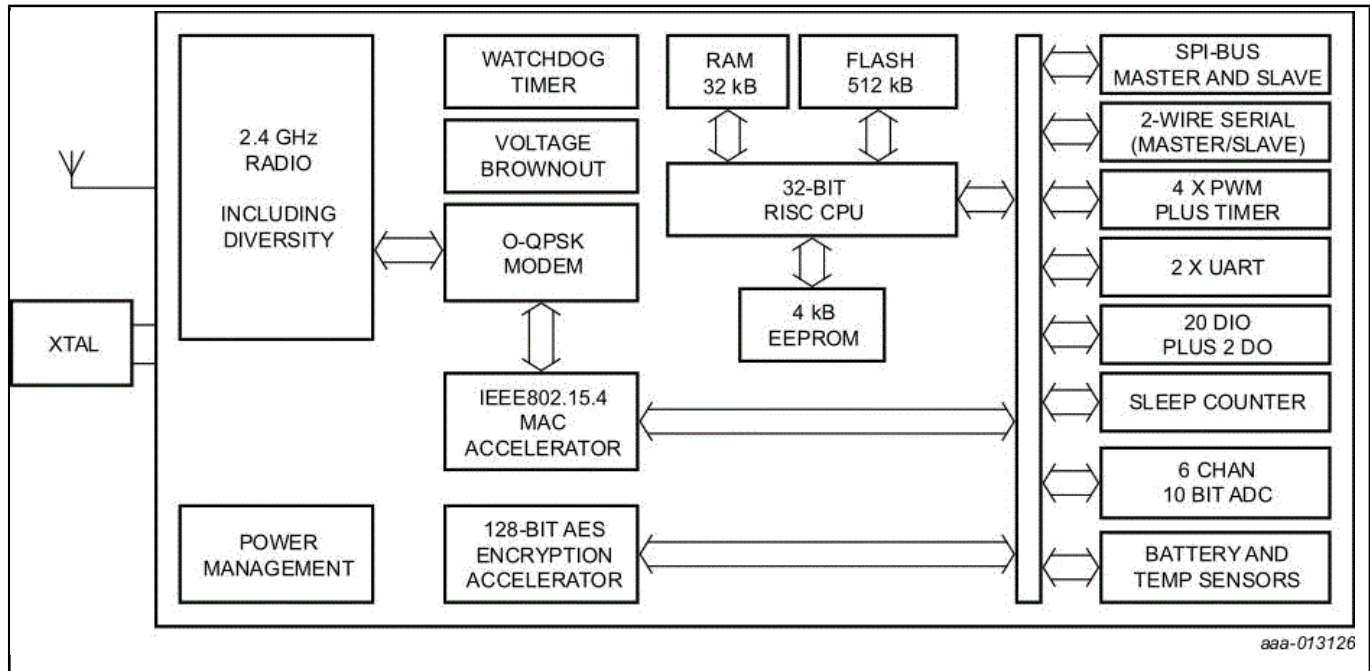

View additional information for [ZigBee and IEEE802.15.4 Wireless Microcontroller with 512 KB Flash, 32 KB RAM](#).

Note: The information on this document is subject to change without notice.

www.nxp.com

NXP and the NXP logo are trademarks of NXP B.V. All other product or service names are the property of their respective owners. The related technology may be protected by any or all of patents, copyrights, designs and trade secrets. All rights reserved. © 2022 NXP B.V.